ryu Documentation

Release 4.0

ryu development team

March 17, 2016

1	Getting Started	3
1.1	What's Ryu	3
1.2	Quick Start	3
1.3	Optional Requirements	3
1.4	Support	4
2	Writing Your Ryu Application	5
2.1	The First Application	5
2.2	Components of Ryu	6
2.3	Ryu application API	10
2.4	Library	14
2.5	OpenFlow protocol API Reference	62
2.6	Nicira Extension Structures	376
2.7	Ryu API Reference	378
3	Configuration	381
3.1	Setup TLS Connection	381
3.2	Topology Viewer	382
4	Tests	385
4.1	Testing VRRP Module	385
4.2	Testing OF-config support with LINC	388
5	Using Ryu Network Operating System with OpenStack as OpenFlow controller	393
6	Snort Intergration	395
6.1	Overview	395
6.2	Installation Snort	396
6.3	Configure Snort	396
6.4	Usage	396
7	Built-in Ryu applications	399
7.1	ryu.app.ofctl	399
7.2	ryu.app.ofctl_rest	400
8	Indices and tables	441
	Python Module Index	443

Contents:

Getting Started

1.1 What's Ryu

Ryu is a component-based software defined networking framework.

Ryu provides software components with well defined API that make it easy for developers to create new network management and control applications. Ryu supports various protocols for managing network devices, such as OpenFlow, Netconf, OF-config, etc. About OpenFlow, Ryu supports fully 1.0, 1.2, 1.3, 1.4, 1.5 and Nicira Extensions.

All of the code is freely available under the Apache 2.0 license. Ryu is fully written in Python.

1.2 Quick Start

Installing Ryu is quite easy:

```
% pip install ryu
```

If you prefer to install Ryu from the source code:

```
% git clone git://github.com/osrg/ryu.git
% cd ryu; python ./setup.py install
```

If you want to write your Ryu application, have a look at [Writing ryu application](#) document. After writing your application, just type:

```
% ryu-manager yourapp.py
```

1.3 Optional Requirements

Some functionalities of ryu requires extra packages:

- OF-Config requires lxml
- NETCONF requires paramiko
- BGP speaker (ssh console) requires paramiko

If you want to use the functionalities, please install requirements:

```
% pip install lxml
% pip install paramiko
```

1.4 Support

Ryu Official site is <http://osrg.github.io/ryu/>.

If you have any questions, suggestions, and patches, the mailing list is available at [ryu-devel ML](#). The ML archive at [Gmane](#) is also available.

Writing Your Ryu Application

2.1 The First Application

2.1.1 Whetting Your Appetite

If you want to manage the network gears (switches, routers, etc) at your way, you need to write your Ryu application. Your application tells Ryu how you want to manage the gears. Then Ryu configures the gears by using OpenFlow protocol, etc.

Writing Ryu application is easy. It's just Python scripts.

2.1.2 Start Writing

We show a Ryu application that make OpenFlow switches work as a dumb layer 2 switch.

Open a text editor creating a new file with the following content:

```
from ryu.base import app_manager

class L2Switch(app_manager.RyuApp):
    def __init__(self, *args, **kwargs):
        super(L2Switch, self).__init__(*args, **kwargs)
```

Ryu application is just a Python script so you can save the file with any name, extensions, and any place you want. Let's name the file 'l2.py' at your home directory.

This application does nothing useful yet, however it's a complete Ryu application. In fact, you can run this Ryu application:

```
% ryu-manager ~/l2.py
loading app /Users/fujita/l2.py
instantiating app /Users/fujita/l2.py
```

All you have to do is defining needs a new subclass of RyuApp to run your Python script as a Ryu application.

Next let's add the functionality of sending a received packet to all the ports.

```
from ryu.base import app_manager
from ryu.controller import ofp_event
from ryu.controller.handler import MAIN_DISPATCHER
from ryu.controller.handler import set_ev_cls

class L2Switch(app_manager.RyuApp):
```

```
def __init__(self, *args, **kwargs):
    super(L2Switch, self).__init__(*args, **kwargs)

@set_ev_cls(ofp_event.EventOFPPacketIn, MAIN_DISPATCHER)
def packet_in_handler(self, ev):
    msg = ev.msg
    dp = msg.datapath
    ofp = dp.ofproto
    ofp_parser = dp.ofproto_parser

    actions = [ofp_parser.OFPActionOutput(ofp.OFPP_FLOOD)]
    out = ofp_parser.OFPPacketOut(
        datapath=dp, buffer_id=msg.buffer_id, in_port=msg.in_port,
        actions=actions)
    dp.send_msg(out)
```

A new method ‘packet_in_handler’ is added to L2Switch class. This is called when Ryu receives an OpenFlow packet_in message. **The trick is ‘set_ev_cls’ decorator.** This decorator tells Ryu when the decorated function should be called.

The first argument of the decorator indicates an event that makes function called. As you expect easily, every time Ryu gets a packet_in message, this function is called.

The second argument indicates the state of the switch. Probably, you want to ignore packet_in messages before the negotiation between Ryu and the switch finishes. Using ‘MAIN_DISPATCHER’ as the second argument means this function is called only after the negotiation completes.

Next let’s look at the first half of the ‘packet_in_handler’ function.

- ev.msg is an object that represents a **packet_in data structure.**
- msg.dp is an object that represents a datapath (switch).
- dp.ofproto and dp.ofproto_parser are objects that represent the OpenFlow protocol that Ryu and the switch negotiated.

Ready for the second half.

- OFPActionOutput class is used with a packet_out message to specify a switch port that you want to send the packet out of. This application need a switch to send out of all the ports so OFPP_FLOOD constant is used.
- **OFPPacketOut class is used to build a packet_out message.**
- If you call Datapath class’s send_msg method with a OpenFlow message class object, Ryu builds and send the on-wire data format to the switch.

Here, you finished implementing your first Ryu application. You are ready to run this Ryu application that does something useful.

A dumb l2 switch is too dumb? You want to implement a learning l2 switch? Move to [the next step](#). You can learn from the existing Ryu applications at [ryu/app](#) directory and [integrated tests](#) directory.

2.2 Components of Ryu

2.2.1 Executables

bin/ryu-manager

The main executable.

2.2.2 Base components

ryu.base.app_manager

The central management of Ryu applications.

- Load Ryu applications
- Provide *contexts* to Ryu applications
- Route messages among Ryu applications

2.2.3 OpenFlow controller

ryu.controller.controller

The main component of OpenFlow controller.

- Handle connections from switches
- Generate and route events to appropriate entities like Ryu applications

ryu.controller.dpset

Manage switches.

Planned to be replaced by ryu/topology.

ryu.controller.ofp_event

OpenFlow event definitions.

ryu.controller.ofp_handler

Basic OpenFlow handling including negotiation.

2.2.4 OpenFlow wire protocol encoder and decoder

ryu.ofproto.ofproto_v1_0

OpenFlow 1.0 definitions.

ryu.ofproto.ofproto_v1_0_parser

Decoder/Encoder implementations of OpenFlow 1.0.

ryu.ofproto.ofproto_v1_2

OpenFlow 1.2 definitions.

ryu.ofproto.ofproto_v1_2_parser

Decoder/Encoder implementations of OpenFlow 1.2.

ryu.ofproto.ofproto_v1_3

OpenFlow 1.3 definitions.

ryu.ofproto.ofproto_v1_3_parser

This module implements OpenFlow 1.3.x.

This module also implements some of extensions shown in “OpenFlow Extensions for 1.3.X Pack 1”. Namely, the following extensions are implemented.

- EXT-236 Bad flow entry priority error Extension
- EXT-237 Set async config error Extension
- EXT-256 PBB UCA header field Extension
- EXT-260 Duplicate instruction error Extension
- EXT-264 Multipart timeout errors Extension

The following extensions are partially implemented.

- EXT-187 Flow entry notifications Extension (ONFMP_FLOW_MONITOR only)
- EXT-230 Bundle Extension (Error codes only)
- EXT-232 Table synchronisation Extension (Error codes only)

The following extensions are not implemented yet.

- EXT-191 Role Status Extension
- EXT-192-e Flow entry eviction Extension
- EXT-192-v Vacancy events Extension

ryu.ofproto.ofproto_v1_4

OpenFlow 1.4 definitions.

ryu.ofproto.ofproto_v1_4_parser

Decoder/Encoder implementations of OpenFlow 1.4.

ryu.ofproto.ofproto_v1_5

OpenFlow 1.5 definitions.

ryu.ofproto.ofproto_v1_5_parser

Decoder/Encoder implementations of OpenFlow 1.5.

2.2.5 Ryu applications

ryu.app.cbench

A dumb OpenFlow 1.0 responder for benchmarking the controller framework. Intended to be used with oflops cbench.

ryu.app.simple_switch

An OpenFlow 1.0 L2 learning switch implementation.

ryu.topology

Switch and link discovery module. Planned to replace ryu/controller/dpset.

2.2.6 Libraries

ryu.lib.packet

Ryu packet library. Decoder/Encoder implementations of popular protocols like TCP/IP.

ryu.lib.ovs

ovsdb interaction library.

ryu.lib.of_config

OF-Config implementation.

ryu.lib.netconf

NETCONF definitions used by ryu/lib/of_config.

ryu.lib.xflow

An implementation of sFlow and NetFlow.

2.2.7 Third party libraries

ryu.contrib.ovs

Open vSwitch python binding. Used by ryu.lib.ovs.

ryu.contrib.oslo.config

Oslo configuration library. Used for ryu-manager's command-line options and configuration files.

ryu.contrib.ncclient

Python library for NETCONF client. Used by `ryu.lib.of_config`.

2.3 Ryu application API

2.3.1 Ryu application programming model

Threads, events, and event queues

Ryu applications are single-threaded entities which implement various functionalities in Ryu. Events are messages between them.

Ryu applications send asynchronous events each other. Besides that, there are some Ryu-internal event sources which are not Ryu applications. One of examples of such event sources is OpenFlow controller. While an event can currently contain arbitrary python objects, it's discouraged to pass complex objects (eg. unpickleable objects) between Ryu applications.

Each Ryu application has a receive queue for events. The queue is FIFO and preserves the order of events. Each Ryu application has a thread for event processing. The thread keep draining the receive queue by dequeuing an event and calling the appropriate event handler for the event type. Because the event handler is called in the context of the event processing thread, it should be careful for blocking. I.e. while an event handler is blocked, no further events for the Ryu application will be processed.

There are kinds of events which are used to implement synchronous inter-application calls between Ryu applications. While such requests uses the same machinery as ordinary events, their replies are put on a queue dedicated to the transaction to avoid deadlock.

While threads and queues is currently implemented with `eventlet/greenlet`, a direct use of them in a Ryu application is strongly discouraged.

Contexts

Contexts are ordinary python objects shared among Ryu applications. The use of contexts are discouraged for new code.

2.3.2 Create a Ryu application

A Ryu application is a python module which defines a subclass of `ryu.base.app_manager.RyuApp`. If two or more such classes are defined in a module, the first one (by name order) will be picked by `app_manager`. Ryu application is singleton: only single instance of a given Ryu application is supported.

2.3.3 Observe events

A Ryu application can register itself to listen for specific events using `ryu.controller.handler.set_ev_cls` decorator.

2.3.4 Generate events

A Ryu application can raise events by calling appropriate `ryu.base.app_manager.RyuApp`'s methods like `send_event` or `send_event_to_observers`.

2.3.5 Event classes

An event class describes a Ryu event generated in the system. By convention, **event class names are prefixed by "Event"**. Events are generated either by the core part of Ryu or Ryu applications. A Ryu application can register its interest for a specific type of event by providing a handler method using `ryu.controller.handler.set_ev_cls` decorator.

OpenFlow event classes

`ryu.controller.ofp_event` module exports event classes which describe receptions of OpenFlow messages from connected switches. By convention, they are named as `ryu.controller.ofp_event.EventOFPxxxx` where `xxxx` is the name of the corresponding OpenFlow message. For example, `EventOFPPacketIn` for packet-in message. **The OpenFlow controller part of Ryu automatically decodes OpenFlow messages received from switches and send these events to Ryu applications which expressed an interest using `ryu.controller.handler.set_ev_cls`.** OpenFlow event classes have at least the following attributes.

Attribute	Description
<code>msg</code>	An object which describes the corresponding OpenFlow message.
<code>msg.datapath</code>	A <code>ryu.controller.controller.Datapath</code> instance which describes an OpenFlow switch from which we received this OpenFlow message.

The `msg` object has some more additional members whose values are extracted from the original OpenFlow message. See *OpenFlow protocol API Reference* for more info about OpenFlow messages.

2.3.6 `ryu.base.app_manager.RyuApp`

See *Ryu API Reference*.

2.3.7 `ryu.controller.handler.set_ev_cls(ev_cls, dispatchers=None)`

A decorator for Ryu application to declare an event handler. Decorated method will become an event handler. **`ev_cls` is an event class whose instances this `RyuApp` wants to receive.** `dispatchers` argument specifies one of the following negotiation phases (or a list of them) for which events should be generated for this handler. Note that, in case an event changes the phase, the phase before the change is used to check the interest.

Negotiation phase	Description
<code>ryu.controller.handler.HANDSHAKE_DISPATCHER</code>	Sending and waiting for hello message
<code>ryu.controller.handler.CONFIG_DISPATCHER</code>	Version negotiated and sent features-request message
<code>ryu.controller.handler.MAIN_DISPATCHER</code>	Switch-features message received and sent set-config message
<code>ryu.controller.handler.DEAD_DISPATCHER</code>	Disconnect from the peer. Or disconnecting due to some unrecoverable errors.

2.3.8 `ryu.controller.controller.Datapath`

A class to describe an OpenFlow switch connected to this controller. An instance has the following attributes.

Attribute	Description
id	64-bit OpenFlow Datapath ID. Only available for <code>ryu.controller.handler.MAIN_DISPATCHER</code> phase.
ofproto	A module which exports OpenFlow definitions, mainly constants appeared in the specification, for the negotiated OpenFlow version. For example, <code>ryu.ofproto.ofproto_v1_0</code> for OpenFlow 1.0.
ofproto_parser	A module which exports OpenFlow wire message encoder and decoder for the negotiated OpenFlow version. For example, <code>ryu.ofproto.ofproto_v1_0_parser</code> for OpenFlow 1.0.
ofproto_parser.OFPxxx(datapath, ...)	A callable to prepare an OpenFlow message for the given switch. It can be sent with <code>Datapath.send_msg</code> later. xxxx is a name of the message. For example <code>OFPFlowMod</code> for flow-mod message. Arguments depend on the message.
<code>set_xid(self, msg)</code>	Generate an OpenFlow XID and put it in <code>msg.xid</code> .
<code>send_msg(self, msg)</code>	Queue an OpenFlow message to send to the corresponding switch. If <code>msg.xid</code> is None, <code>set_xid</code> is automatically called on the message before queueing.
<code>send_packet_out</code>	deprecated
<code>send_flow_mod</code>	deprecated
<code>send_flow_del</code>	deprecated
<code>send_delete_all_flows</code>	deprecated
<code>send_barrier</code>	Queue an OpenFlow barrier message to send to the switch.
<code>send_nxt_set_flow_format</code>	deprecated
<code>is_reserved_port</code>	deprecated

2.3.9 ryu.controller.event.EventBase

The base of all event classes. A Ryu application can define its own event type by creating a subclass.

2.3.10 ryu.controller.event.EventRequestBase

The base class for synchronous request for `RyuApp.send_request`.

2.3.11 ryu.controller.event.EventReplyBase

The base class for synchronous request reply for `RyuApp.send_reply`.

2.3.12 ryu.controller.ofp_event.EventOFPSStateChange

An event class for negotiation phase change notification. An instance of this class is sent to observer after changing the negotiation phase. An instance has at least the following attributes.

Attribute	Description
datapath	<code>ryu.controller.controller.Datapath</code> instance of the switch

2.3.13 ryu.controller.dpset.EventDP

An event class to notify connect/disconnect of a switch. For OpenFlow switches, one can get the same notification by observing `ryu.controller.ofp_event.EventOFPSStateChange`. An instance has at least the following attributes.

Attribute	Description
dp	A ryu.controller.controller.Datapath instance of the switch
enter	True when the switch connected to our controller. False for disconnect.

2.3.14 ryu.controller.dpset.EventPortAdd

An event class for switch port status notification. This event is generated when a new port is added to a switch. For OpenFlow switches, one can get the same notification by observing ryu.controller.ofp_event.EventOFPPortStatus. An instance has at least the following attributes.

Attribute	Description
dp	A ryu.controller.controller.Datapath instance of the switch
port	port number

2.3.15 ryu.controller.dpset.EventPortDelete

An event class for switch port status notification. This event is generated when a port is removed from a switch. For OpenFlow switches, one can get the same notification by observing ryu.controller.ofp_event.EventOFPPortStatus. An instance has at least the following attributes.

Attribute	Description
dp	A ryu.controller.controller.Datapath instance of the switch
port	port number

2.3.16 ryu.controller.dpset.EventPortModify

An event class for switch port status notification. This event is generated when some attribute of a port is changed. For OpenFlow switches, one can get the same notification by observing ryu.controller.ofp_event.EventOFPPortStatus. An instance has at least the following attributes.

Attribute	Description
dp	A ryu.controller.controller.Datapath instance of the switch
port	port number

2.3.17 ryu.controller.network.EventNetworkPort

An event class for notification of port arrival and departure. This event is generated when a port is introduced to or removed from a network by the REST API. An instance has at least the following attributes.

Attribute	Description
network_id	Network ID
dpid	OpenFlow Datapath ID of the switch to which the port belongs.
port_no	OpenFlow port number of the port
add_del	True for adding a port. False for removing a port.

2.3.18 ryu.controller.network.EventNetworkDel

An event class for network deletion. This event is generated when a network is deleted by the REST API. An instance has at least the following attributes.

Attribute	Description
network_id	Network ID

2.3.19 ryu.controller.network.EventMacAddress

An event class for end-point MAC address registration. This event is generated when a end-point MAC address is updated by the REST API. An instance has at least the following attributes.

Attribute	Description
network_id	Network ID
dpid	OpenFlow Datapath ID of the switch to which the port belongs.
port_no	OpenFlow port number of the port
mac_address	The old MAC address of the port if add_del is False. Otherwise the new MAC address.
add_del	False if this event is a result of a port removal. Otherwise True.

2.3.20 ryu.controller.tunnels.EventTunnelKeyAdd

An event class for tunnel key registration. This event is generated when a tunnel key is registered or updated by the REST API. An instance has at least the following attributes.

Attribute	Description
network_id	Network ID
tunnel_key	Tunnel Key

2.3.21 ryu.controller.tunnels.EventTunnelKeyDel

An event class for tunnel key registration. This event is generated when a tunnel key is removed by the REST API. An instance has at least the following attributes.

Attribute	Description
network_id	Network ID
tunnel_key	Tunnel Key

2.3.22 ryu.controller.tunnels.EventTunnelPort

An event class for tunnel port registration. This event is generated when a tunnel port is added or removed by the REST API. An instance has at least the following attributes.

Attribute	Description
dpid	OpenFlow Datapath ID
port_no	OpenFlow port number
remote_dpid	OpenFlow port number of the tunnel peer
add_del	True for adding a tunnel. False for removal.

2.4 Library

Ryu provides some useful library for your network applications.

2.4.1 Packet library

Introduction

Ryu packet library helps you to parse and build various protocol packets. dpkt is the popular library for the same purpose, however it is not designed to handle protocols that are interleaved; vlan, mpls, gre, etc. So we implemented our own packet library.

Network Addresses

Unless otherwise specified, MAC/IPv4/IPv6 addresses are specified using human readable strings for this library. For example, '08:60:6e:7f:74:e7', '192.0.2.1', 'fe80::a60:6eff:fe7f:74e7'.

Parsing Packet

First, let's look at how we can use the library to parse the received packets in a handler for OFPPacketIn messages.

```
from ryu.lib.packet import packet

@handler.set_ev_cls(ofp_event.EventOFPPacketIn, handler.MAIN_DISPATCHER)
def packet_in_handler(self, ev):
    pkt = packet.Packet(array.array('B', ev.msg.data))
    for p in pkt.protocols:
        print p
```

You can create a Packet class instance with the received raw data. Then the packet library parses the data and creates protocol class instances included the data. The packet class 'protocols' has the protocol class instances.

If a TCP packet is received, something like the following is printed:

```
<ryu.lib.packet.ethernet.ethernet object at 0x107a5d790>
<ryu.lib.packet.vlan.vlan object at 0x107a5d7d0>
<ryu.lib.packet.ipv4.ipv4 object at 0x107a5d810>
<ryu.lib.packet.tcp.tcp object at 0x107a5d850>
```

If vlan is not used, you see something like:

```
<ryu.lib.packet.ethernet.ethernet object at 0x107a5d790>
<ryu.lib.packet.ipv4.ipv4 object at 0x107a5d810>
<ryu.lib.packet.tcp.tcp object at 0x107a5d850>
```

You can access to a specific protocol class instance by using the packet class iterator. Let's try to check VLAN id if VLAN is used:

```
from ryu.lib.packet import packet

@handler.set_ev_cls(ofp_event.EventOFPPacketIn, handler.MAIN_DISPATCHER)
def packet_in_handler(self, ev):
    pkt = packet.Packet(array.array('B', ev.msg.data))
    for p in pkt:
        print p.protocol_name, p
        if p.protocol_name == 'vlan':
            print 'vid = ', p.vid
```

You see something like:

```
ethernet <ryu.lib.packet.ethernet.ethernet object at 0x107a5d790>
vlan <ryu.lib.packet.vlan.vlan object at 0x107a5d7d0>
vid = 10
ipv4 <ryu.lib.packet.ipv4.ipv4 object at 0x107a5d810>
tcp <ryu.lib.packet.tcp.tcp object at 0x107a5d850>
```

Building Packet

You need to create protocol class instances that you want to send, add them to a packet class instance via `add_protocol` method, and then call `serialize` method. You have the raw data to send. The following example is building an arp packet.

```
from ryu.ofproto import ether
from ryu.lib.packet import ethernet, arp, packet

e = ethernet.ethernet(dst='ff:ff:ff:ff:ff:ff',
                      src='08:60:6e:7f:74:e7',
                      ethertype=ether.ETH_TYPE_ARP)
a = arp.arp(hwtype=1, proto=0x0800, hlen=6, plen=4, opcode=2,
           src_mac='08:60:6e:7f:74:e7', src_ip='192.0.2.1',
           dst_mac='00:00:00:00:00:00', dst_ip='192.0.2.2')
p = packet.Packet()
p.add_protocol(e)
p.add_protocol(a)
p.serialize()
print repr(p.data) # the on-wire packet
```

2.4.2 Packet library API Reference

Packet class

class `ryu.lib.packet.packet.Packet` (*data=None, protocols=None, parse_cls=<class 'ryu.lib.packet.ethernet.ethernet'>*)

A packet decoder/encoder class.

An instance is used to either decode or encode a single packet.

data is a bytearray to describe a raw datagram to decode. When decoding, a `Packet` object is iterable. Iterated values are protocol (ethernet, ipv4, ...) headers and the payload. Protocol headers are instances of subclass of `packet_base.PacketBase`. The payload is a bytearray. They are iterated in on-wire order.

data should be omitted when encoding a packet.

add_protocol (*proto*)

Register a protocol *proto* for this packet.

This method is legal only when encoding a packet.

When encoding a packet, register a protocol (ethernet, ipv4, ...) header to add to this packet. Protocol headers should be registered in on-wire order before calling `self.serialize`.

get_protocol (*protocol*)

Returns the firstly found protocol that matches to the specified protocol.

get_protocols (*protocol*)

Returns a list of protocols that matches to the specified protocol.

serialize()

Encode a packet and store the resulted bytearray in self.data.

This method is legal only when encoding a packet.

Stream Parser class**class** ryu.lib.packet.stream_parser.**StreamParser**

Streaming parser base class.

An instance of a subclass of this class is used to extract messages from a raw byte stream.

It's designed to be used for data read from a transport which doesn't preserve message boundaries. A typical example of such a transport is TCP.

parse (*data*)

Tries to extract messages from a raw byte stream.

The data argument would be python bytes newly read from the input stream.

Returns an ordered list of extracted messages. It can be an empty list.

The rest of data which doesn't produce a complete message is kept internally and will be used when more data is come. I.e. next time this method is called again.

try_parse (*q*)

Try to extract a message from the given bytes.

This is an override point for subclasses.

This method tries to extract a message from bytes given by the argument.

Raises TooSmallException if the given data is not enough to extract a complete message but there's still a chance to extract a message if more data is come later.

class ryu.lib.packet.bgp.**StreamParser**

Streaming parser for BGP-4 messages.

This is a subclass of ryu.lib.packet.stream_parser.StreamParser. Its parse method returns a list of BGPMMessage subclass instances.

Protocol Header classes**class** ryu.lib.packet.packet_base.**PacketBase**

A base class for a protocol (ethernet, ipv4, ...) header.

classmethod **get_packet_type** (*type_*)

Per-protocol dict-like get method.

Provided for convenience of protocol implementers. Internal use only.

classmethod **parser** (*buf*)

Decode a protocol header.

This method is used only when decoding a packet.

Decode a protocol header at offset 0 in bytearray *buf*. Returns the following three objects.

- An object to describe the decoded header.
- A packet_base.PacketBase subclass appropriate for the rest of the packet. None when the rest of the packet should be considered as raw payload.

- The rest of packet.

classmethod register_packet_type (*cls_, type_*)

Per-protocol dict-like set method.

Provided for convenience of protocol implementers. Internal use only.

serialize (*payload, prev*)

Encode a protocol header.

This method is used only when encoding a packet.

Encode a protocol header. Returns a bytearray which contains the header.

payload is the rest of the packet which will immediately follow this header.

prev is a packet_base.PacketBase subclass for the outer protocol header. *prev* is None if the current header is the outer-most. For example, *prev* is ipv4 or ipv6 for tcp.serialize.

class ryu.lib.packet.ethernet.**ethernet** (*dst='ff:ff:ff:ff:ff:ff', src='00:00:00:00:00:00', ether-
type=2048*)

Ethernet header encoder/decoder class.

An instance has the following attributes at least. MAC addresses are represented as a string like '08:60:6e:7f:74:e7'. `__init__` takes the corresponding args in this order.

Attribute	Description	Example
dst	destination address	'ff:ff:ff:ff:ff:ff'
src	source address	'08:60:6e:7f:74:e7'
ethertype	ether type	0x0800

classmethod get_packet_type (*type_*)

Override method for the ethernet IEEE802.3 Length/Type field (self.ethertype).

If the value of Length/Type field is less than or equal to 1500 decimal(05DC hexadecimal), it means Length interpretation and be passed to the LLC sublayer.

class ryu.lib.packet.vlan.**svlan** (*pcp=0, cfi=0, vid=0, ethertype=33024*)

S-VLAN (IEEE 802.1ad) header encoder/decoder class.

An instance has the following attributes at least. Most of them are same to the on-wire counterparts but in host byte order. `__init__` takes the corresponding args in this order.

Attribute	Description
pcp	Priority Code Point
cfi	Canonical Format Indicator. In a case to be used as B-TAG, this field means DEI(Drop Eligible Indication).
vid	VLAN Identifier
ethertype	EtherType

class ryu.lib.packet.vlan.**vlan** (*pcp=0, cfi=0, vid=0, ethertype=2048*)

VLAN (IEEE 802.1Q) header encoder/decoder class.

An instance has the following attributes at least. Most of them are same to the on-wire counterparts but in host byte order. `__init__` takes the corresponding args in this order.

Attribute	Description
pcp	Priority Code Point
cfi	Canonical Format Indicator
vid	VLAN Identifier
ethertype	EtherType

classmethod `get_packet_type` (*type_*)

Override method for the Length/Type field (`self.ethertype`). The Length/Type field means Length or Type interpretation, same as ethernet IEEE802.3. If the value of Length/Type field is less than or equal to 1500 decimal (05DC hexadecimal), it means Length interpretation and be passed to the LLC sublayer.

class `ryu.lib.packet.pbb.itag` (*pcp=0, dei=0, uca=0, sid=0*)

I-TAG (IEEE 802.1ah-2008) header encoder/decoder class.

An instance has the following attributes at least. Most of them are same to the on-wire counterparts but in host byte order. `__init__` takes the corresponding args in this order.

Attribute	Description
<code>pcp</code>	Priority Code Point
<code>dei</code>	Drop Eligible Indication
<code>uca</code>	Use Customer Address
<code>sid</code>	Service Instance ID

class `ryu.lib.packet.mpls.mpls` (*label=0, exp=0, bsb=1, ttl=255*)

MPLS (RFC 3032) header encoder/decoder class.

NOTE: When decoding, this implementation assumes that the inner protocol is IPv4.

An instance has the following attributes at least. Most of them are same to the on-wire counterparts but in host byte order. `__init__` takes the corresponding args in this order.

Attribute	Description
<code>label</code>	Label Value
<code>exp</code>	Experimental Use
<code>bsb</code>	Bottom of Stack
<code>ttl</code>	Time To Live

class `ryu.lib.packet.arp.arp` (*hwtype=1, proto=2048, hlen=6, plen=4, opcode=1, src_mac='ff:ff:ff:ff:ff:ff', src_ip='0.0.0.0', dst_mac='ff:ff:ff:ff:ff:ff', dst_ip='0.0.0.0'*)

ARP (RFC 826) header encoder/decoder class.

An instance has the following attributes at least. Most of them are same to the on-wire counterparts but in host byte order. IPv4 addresses are represented as a string like '192.0.2.1'. MAC addresses are represented as a string like '08:60:6e:7f:74:e7'. `__init__` takes the corresponding args in this order.

Attribute	Description	Example
<code>hwtype</code>	<code>ar\$hrd</code>	
<code>proto</code>	<code>ar\$pro</code>	
<code>hlen</code>	<code>ar\$hln</code>	
<code>plen</code>	<code>ar\$pln</code>	
<code>opcode</code>	<code>ar\$op</code>	
<code>src_mac</code>	<code>ar\$sha</code>	'08:60:6e:7f:74:e7'
<code>src_ip</code>	<code>ar\$spa</code>	'192.0.2.1'
<code>dst_mac</code>	<code>ar\$tha</code>	'00:00:00:00:00:00'
<code>dst_ip</code>	<code>ar\$tpa</code>	'192.0.2.2'

`ryu.lib.packet.arp.arp_ip` (*opcode, src_mac, src_ip, dst_mac, dst_ip*)

A convenient wrapper for IPv4 ARP for Ethernet.

This is an equivalent of the following code.

```
arp(ARP_HW_TYPE_ETHERNET, ether.ETH_TYPE_IP, 6, 4, opcode, src_mac, src_ip, dst_mac,
dst_ip)
```

class `ryu.lib.packet.ipv4.ipv4` (*version=4, header_length=5, tos=0, total_length=0, identification=0, flags=0, offset=0, ttl=255, proto=0, csum=0, src='10.0.0.1', dst='10.0.0.2', option=None*)

IPv4 (RFC 791) header encoder/decoder class.

NOTE: When decoding, this implementation tries to decode the upper layer protocol even for a fragmented datagram. It isn't likely what a user would want.

An instance has the following attributes at least. Most of them are same to the on-wire counterparts but in host byte order. IPv4 addresses are represented as a string like '192.0.2.1'. `__init__` takes the corresponding args in this order.

Attribute	Description	Example
<code>version</code>	Version	
<code>header_length</code>	IHL	
<code>tos</code>	Type of Service	
<code>total_length</code>	Total Length (0 means automatically-calculate when encoding)	
<code>identification</code>	Identification	
<code>flags</code>	Flags	
<code>offset</code>	Fragment Offset	
<code>ttl</code>	Time to Live	
<code>proto</code>	Protocol	
<code>csum</code>	Header Checksum (Ignored and automatically-calculated when encoding)	
<code>src</code>	Source Address	'192.0.2.1'
<code>dst</code>	Destination Address	'192.0.2.2'
<code>option</code>	A bytearray which contains the entire Options, or None for no Options	

class `ryu.lib.packet.icmp.TimeExceeded` (*data_len=0, data=None*)

ICMP sub encoder/decoder class for Time Exceeded Message.

This is used with `ryu.lib.packet.icmp.icmp` for ICMP Time Exceeded Message.

An instance has the following attributes at least. Most of them are same to the on-wire counterparts but in host byte order. `__init__` takes the corresponding args in this order.

[RFC4884] introduced 8-bit data length attribute.

Attribute	Description
<code>data_len</code>	data length
<code>data</code>	Internet Header + leading octets of original datagram

class `ryu.lib.packet.icmp.dest_unreach` (*data_len=0, mtu=0, data=None*)

ICMP sub encoder/decoder class for Destination Unreachable Message.

This is used with `ryu.lib.packet.icmp.icmp` for ICMP Destination Unreachable Message.

An instance has the following attributes at least. Most of them are same to the on-wire counterparts but in host byte order. `__init__` takes the corresponding args in this order.

[RFC1191] reserves bits for the "Next-Hop MTU" field. [RFC4884] introduced 8-bit data length attribute.

Attribute	Description
<code>data_len</code>	data length
<code>mtu</code>	Next-Hop MTU NOTE: This field is required when icmp code is 4 code 4 = fragmentation needed and DF set
<code>data</code>	Internet Header + leading octets of original datagram

class `ryu.lib.packet.icmp.echo` (*id_=0, seq=0, data=None*)

ICMP sub encoder/decoder class for Echo and Echo Reply messages.

This is used with `ryu.lib.packet.icmp.icmp` for ICMP Echo and Echo Reply messages.

An instance has the following attributes at least. Most of them are same to the on-wire counterparts but in host byte order. `__init__` takes the corresponding args in this order.

Attribute	Description
id	Identifier
seq	Sequence Number
data	Internet Header + 64 bits of Original Data Datagram

class `ryu.lib.packet.icmp.icmp` (*type_=8, code=0, csum=0, data=None*)
 ICMP (RFC 792) header encoder/decoder class.

An instance has the following attributes at least. Most of them are same to the on-wire counterparts but in host byte order. `__init__` takes the corresponding args in this order.

Attribute	Description
type	Type
code	Code
csum	Checksum (0 means automatically-calculate when encoding)
data	Payload. Either a bytearray, or <code>ryu.lib.packet.icmp.echo</code> or <code>ryu.lib.packet.icmp.dest_unreach</code> or <code>ryu.lib.packet.icmp.TimeExceeded</code> object NOTE for <code>icmp.echo</code> : This includes “unused” 16 bits and the following “Internet Header + 64 bits of Original Data Datagram” of the ICMP header. NOTE for <code>icmp.dest_unreach</code> and <code>icmp.TimeExceeded</code> : This includes “unused” 8 or 24 bits and the following “Internet Header + leading octets of original datagram” of the original packet.

class `ryu.lib.packet.ipv6.auth` (*nxt=6, size=2, spi=0, seq=0, data='x00x00x00x00'*)
 IP Authentication header (RFC 2402) encoder/decoder class.

This is used with `ryu.lib.packet.ipv6.ipv6`.

An instance has the following attributes at least. Most of them are same to the on-wire counterparts but in host byte order. `__init__` takes the corresponding args in this order.

Attribute	Description
nxt	Next Header
size	the length of the Authentication Header in 64-bit words, subtracting 1.
spi	security parameters index.
seq	sequence number.
data	authentication data.

class `ryu.lib.packet.ipv6.dst_opts` (*nxt=6, size=0, data=None*)
 IPv6 (RFC 2460) destination header encoder/decoder class.

This is used with `ryu.lib.packet.ipv6.ipv6`.

An instance has the following attributes at least. Most of them are same to the on-wire counterparts but in host byte order. `__init__` takes the corresponding args in this order.

Attribute	Description
nxt	Next Header
size	the length of the destination header, not include the first 8 octet.
data	IPv6 options.

class `ryu.lib.packet.ipv6.fragment` (*nxt=6, offset=0, more=0, id_=0*)
 IPv6 (RFC 2460) fragment header encoder/decoder class.

This is used with `ryu.lib.packet.ipv6.ipv6`.

An instance has the following attributes at least. Most of them are same to the on-wire counterparts but in host byte order. `__init__` takes the corresponding args in this order.

Attribute	Description
<code>nxt</code>	Next Header
<code>offset</code>	offset, in 8-octet units, relative to the start of the fragmentable part of the original packet.
<code>more</code>	1 means more fragments follow; 0 means last fragment.
<code>id_</code>	packet identification value.

class `ryu.lib.packet.ipv6.header` (*nxt*)
extension header abstract class.

class `ryu.lib.packet.ipv6.hop_opts` (*nxt=6, size=0, data=None*)
IPv6 (RFC 2460) Hop-by-Hop Options header encoder/decoder class.

This is used with `ryu.lib.packet.ipv6.ipv6`.

An instance has the following attributes at least. Most of them are same to the on-wire counterparts but in host byte order. `__init__` takes the corresponding args in this order.

Attribute	Description
<code>nxt</code>	Next Header
<code>size</code>	the length of the Hop-by-Hop Options header, not include the first 8 octet.
<code>data</code>	IPv6 options.

class `ryu.lib.packet.ipv6.ipv6` (*version=6, traffic_class=0, flow_label=0, payload_length=0, nxt=6, hop_limit=255, src='10::10', dst='20::20', ext_hdrs=None*)
IPv6 (RFC 2460) header encoder/decoder class.

An instance has the following attributes at least. Most of them are same to the on-wire counterparts but in host byte order. IPv6 addresses are represented as a string like `'ff02::1'`. `__init__` takes the corresponding args in this order.

Attribute	Description	Example
<code>version</code>	Version	
<code>traffic_class</code>	Traffic Class	
<code>flow_label</code>	When decoding, Flow Label. When encoding, the most significant 8 bits of Flow Label.	
<code>payload_length</code>	Payload Length	
<code>nxt</code>	Next Header	
<code>hop_limit</code>	Hop Limit	
<code>src</code>	Source Address	<code>'ff02::1'</code>
<code>dst</code>	Destination Address	<code>'::'</code>
<code>ext_hdrs</code>	Extension Headers	

class `ryu.lib.packet.ipv6.opt_header` (*nxt, size, data*)
an abstract class for Hop-by-Hop Options header and destination header.

class `ryu.lib.packet.ipv6.option` (*type_=0, len_=-1, data=None*)
IPv6 (RFC 2460) Options header encoder/decoder class.

This is used with `ryu.lib.packet.ipv6.hop_opts` or `ryu.lib.packet.ipv6.dst_opts`.

An instance has the following attributes at least. Most of them are same to the on-wire counterparts but in host byte order. `__init__` takes the corresponding args in this order.

Attribute	Description
<code>type_</code>	option type.
<code>len_</code>	the length of data. -1 if <code>type_</code> is 0.
<code>data</code>	an option value. None if <code>len_</code> is 0 or -1.

class `ryu.lib.packet.ipv6.routing` (*nxt*)

An IPv6 Routing Header decoder class. This class has only the parser method.

IPv6 Routing Header types.

<http://www.iana.org/assignments/ipv6-parameters/ipv6-parameters.xhtml>

Value	Description	Reference
0	Source Route (DEPRECATED)	[[IPv6]][RFC5095]
1	Nimrod (DEPRECATED 2009-05-06)	
2	Type 2 Routing Header	[RFC6275]
3	RPL Source Route Header	[RFC6554]
4 - 252	Unassigned	
253	RFC3692-style Experiment 1 [2]	[RFC4727]
254	RFC3692-style Experiment 2 [2]	[RFC4727]
255	Reserved	

class `ryu.lib.packet.ipv6.routing_type3` (*nxt=6, size=0, type_=3, seg=0, cmpi=0, cmpe=0, adrs=None*)

An IPv6 Routing Header for Source Routes with the RPL (RFC 6554) encoder/decoder class.

This is used with `ryu.lib.packet.ipv6.ipv6`.

An instance has the following attributes at least. Most of them are same to the on-wire counterparts but in host byte order. `__init__` takes the corresponding args in this order.

Attribute	Description
<code>nxt</code>	Next Header
<code>size</code>	The length of the Routing header, not include the first 8 octet. (0 means automatically-calculate when encoding)
<code>type</code>	Identifies the particular Routing header variant.
<code>seg</code>	Number of route segments remaining.
<code>cmpi</code>	Number of prefix octets from segments 1 through n-1.
<code>cmpe</code>	Number of prefix octets from segment n.
<code>pad</code>	Number of octets that are used for padding after Address[n] at the end of the SRH.
<code>adrs</code>	Vector of addresses, numbered 1 to n.

class `ryu.lib.packet.icmpv6.echo` (*id_=0, seq=0, data=None*)

ICMPv6 sub encoder/decoder class for Echo Request and Echo Reply messages.

This is used with `ryu.lib.packet.icmpv6.icmpv6` for ICMPv6 Echo Request and Echo Reply messages.

An instance has the following attributes at least. Most of them are same to the on-wire counterparts but in host byte order. `__init__` takes the corresponding args in this order.

Attribute	Description
<code>id</code>	Identifier
<code>seq</code>	Sequence Number
<code>data</code>	Data

class `ryu.lib.packet.icmpv6.icmpv6` (*type_=0, code=0, csum=0, data=None*)

ICMPv6 (RFC 2463) header encoder/decoder class.

An instance has the following attributes at least. Most of them are same to the on-wire counterparts but in host byte order. `__init__` takes the corresponding args in this order.

Attribute	Description
type_	Type
code	Code
csum	Checksum (0 means automatically-calculate when encoding)
data	Payload. ryu.lib.packet.icmpv6.echo object, ryu.lib.packet.icmpv6.nd_neighbor object, ryu.lib.packet.icmpv6.nd_router_solicit object, ryu.lib.packet.icmpv6.nd_router_advert object, ryu.lib.packet.icmpv6.mld object, or a bytearray.

class `ryu.lib.packet.icmpv6.mld` (*maxresp=0, address='::'*)
 ICMPv6 sub encoder/decoder class for MLD Lister Query, MLD Listener Report, and MLD Listener Done messages. (RFC 2710)

<http://www.ietf.org/rfc/rfc2710.txt>

This is used with `ryu.lib.packet.icmpv6.icmpv6`.

An instance has the following attributes at least. Most of them are same to the on-wire counterparts but in host byte order. `__init__` takes the corresponding args in this order.

Attribute	Description
maxresp	max response time in millisecond. it is meaningful only in Query Message.
address	a group address value.

class `ryu.lib.packet.icmpv6.mldv2_query` (*maxresp=0, address='::', s_flg=0, qrv=2, qqic=0, num=0, srcs=None*)
 ICMPv6 sub encoder/decoder class for MLD v2 Lister Query messages. (RFC 3810)

<http://www.ietf.org/rfc/rfc3810.txt>

This is used with `ryu.lib.packet.icmpv6.icmpv6`.

An instance has the following attributes at least. Most of them are same to the on-wire counterparts but in host byte order. `__init__` takes the corresponding args in this order.

Attribute	Description
maxresp	max response time in millisecond. it is meaningful only in Query Message.
address	a group address value.
s_flg	when set to 1, routers suppress the timer process.
qrv	robustness variable for a querier.
qqic	an interval time for a querier in unit of seconds.
num	a number of the multicast servers.
srcs	a list of IPv6 addresses of the multicast servers.

class `ryu.lib.packet.icmpv6.mldv2_report` (*record_num=0, records=None*)
 ICMPv6 sub encoder/decoder class for MLD v2 Lister Report messages. (RFC 3810)

<http://www.ietf.org/rfc/rfc3810.txt>

This is used with `ryu.lib.packet.icmpv6.icmpv6`.

An instance has the following attributes at least. Most of them are same to the on-wire counterparts but in host byte order. `__init__` takes the corresponding args in this order.

Attribute	Description
record_num	a number of the group records.
records	a list of <code>ryu.lib.packet.icmpv6.mldv2_report_group</code> . None if no records.

class `ryu.lib.packet.icmpv6.mldv2_report_group` (*type_=0, aux_len=0, num=0, address='::', srcs=None, aux=None*)
 ICMPv6 sub encoder/decoder class for MLD v2 Lister Report Group Record messages. (RFC 3810)

This is used with `ryu.lib.packet.icmpv6.mldv2_report`.

An instance has the following attributes at least. Most of them are same to the on-wire counterparts but in host byte order. `__init__` takes the corresponding args in this order.

Attribute	Description
<code>type_</code>	a group record type for v3.
<code>aux_len</code>	the length of the auxiliary data in 32-bit words.
<code>num</code>	a number of the multicast servers.
<code>address</code>	a group address value.
<code>srcs</code>	a list of IPv6 addresses of the multicast servers.
<code>aux</code>	the auxiliary data.

class `ryu.lib.packet.icmpv6.nd_neighbor` (*res=0, dst='::', option=None*)

ICMPv6 sub encoder/decoder class for Neighbor Solicitation and Neighbor Advertisement messages. (RFC 4861)

This is used with `ryu.lib.packet.icmpv6.icmpv6`.

An instance has the following attributes at least. Most of them are same to the on-wire counterparts but in host byte order. `__init__` takes the corresponding args in this order.

Attribute	Description
<code>res</code>	R,S,O Flags for Neighbor Advertisement. The 3 MSBs of “Reserved” field for Neighbor Solicitation.
<code>dst</code>	Target Address
<code>option</code>	a derived object of <code>ryu.lib.packet.icmpv6.nd_option</code> or a bytearray. None if no options.

class `ryu.lib.packet.icmpv6.nd_option_pi` (*length=0, pl=0, res1=0, val_l=0, pre_l=0, res2=0, prefix='::'*)

ICMPv6 sub encoder/decoder class for Neighbor discovery Prefix Information Option. (RFC 4861)

This is used with `ryu.lib.packet.icmpv6.nd_router_advert`.

An instance has the following attributes at least. Most of them are same to the on-wire counterparts but in host byte order. `__init__` takes the corresponding args in this order.

Attribute	Description
<code>length</code>	length of the option. (0 means automatically-calculate when encoding)
<code>pl</code>	Prefix Length.
<code>res1</code>	L,A,R* Flags for Prefix Information.
<code>val_l</code>	Valid Lifetime.
<code>pre_l</code>	Preferred Lifetime.
<code>res2</code>	This field is unused. It MUST be initialized to zero.
<code>prefix</code>	An IP address or a prefix of an IP address.

*R flag is defined in (RFC 3775)

class `ryu.lib.packet.icmpv6.nd_option_sla` (*length=0, hw_src='00:00:00:00:00:00', data=None*)

ICMPv6 sub encoder/decoder class for Neighbor discovery Source Link-Layer Address Option. (RFC 4861)

This is used with `ryu.lib.packet.icmpv6.nd_neighbor`, `ryu.lib.packet.icmpv6.nd_router_solicit` or `ryu.lib.packet.icmpv6.nd_router_advert`.

An instance has the following attributes at least. Most of them are same to the on-wire counterparts but in host byte order. `__init__` takes the corresponding args in this order.

Attribute	Description
length	length of the option. (0 means automatically-calculate when encoding)
hw_src	Link-Layer Address. NOTE: If the address is longer than 6 octets this contains the first 6 octets in the address. This implementation assumes the address has at least 6 octets.
data	A bytearray which contains the rest of Link-Layer Address and padding. When encoding a packet, it's user's responsibility to provide necessary padding for 8-octets alignment required by the protocol.

class `ryu.lib.packet.icmpv6.nd_option_tla` (*length=0, hw_src='00:00:00:00:00:00', data=None*)

ICMPv6 sub encoder/decoder class for Neighbor discovery Target Link-Layer Address Option. (RFC 4861)

This is used with `ryu.lib.packet.icmpv6.nd_neighbor`.

An instance has the following attributes at least. Most of them are same to the on-wire counterparts but in host byte order. `__init__` takes the corresponding args in this order.

Attribute	Description
length	length of the option. (0 means automatically-calculate when encoding)
hw_src	Link-Layer Address. NOTE: If the address is longer than 6 octets this contains the first 6 octets in the address. This implementation assumes the address has at least 6 octets.
data	A bytearray which contains the rest of Link-Layer Address and padding. When encoding a packet, it's user's responsibility to provide necessary padding for 8-octets alignment required by the protocol.

class `ryu.lib.packet.icmpv6.nd_router_advert` (*ch_l=0, res=0, rou_l=0, rea_t=0, ret_t=0, options=None*)

ICMPv6 sub encoder/decoder class for Router Advertisement messages. (RFC 4861)

This is used with `ryu.lib.packet.icmpv6.icmpv6`.

An instance has the following attributes at least. Most of them are same to the on-wire counterparts but in host byte order. `__init__` takes the corresponding args in this order.

Attribute	Description
ch_l	Cur Hop Limit.
res	M,O Flags for Router Advertisement.
rou_l	Router Lifetime.
rea_t	Reachable Time.
ret_t	Retrans Timer.
options	List of a derived object of <code>ryu.lib.packet.icmpv6.nd_option</code> or a bytearray. None if no options.

class `ryu.lib.packet.icmpv6.nd_router_solicit` (*res=0, option=None*)

ICMPv6 sub encoder/decoder class for Router Solicitation messages. (RFC 4861)

This is used with `ryu.lib.packet.icmpv6.icmpv6`.

An instance has the following attributes at least. Most of them are same to the on-wire counterparts but in host byte order. `__init__` takes the corresponding args in this order.

Attribute	Description
res	This field is unused. It MUST be initialized to zero.
option	a derived object of <code>ryu.lib.packet.icmpv6.nd_option</code> or a bytearray. None if no options.

class `ryu.lib.packet.cfm.cc_message` (*md_lv=0, version=0, rdi=0, interval=4, seq_num=0, mep_id=1, md_name_format=4, md_name_length=0, md_name='0', short_ma_name_format=2, short_ma_name_length=0, short_ma_name='1', tlvs=None*)

CFM (IEEE Std 802.1ag-2007) Continuity Check Message (CCM) encoder/decoder class.

This is used with `ryu.lib.packet.cfm.cfm`.

An instance has the following attributes at least. Most of them are same to the on-wire counterparts but in host byte order. `__init__` takes the corresponding args in this order.

Attribute	Description
<code>md_lv</code>	Maintenance Domain Level.
<code>version</code>	The protocol version number.
<code>rdi</code>	RDI bit.
<code>interval</code>	CCM Interval.The default is 4 (1 frame/s)
<code>seq_num</code>	Sequence Number.
<code>mep_id</code>	Maintenance association End Point Identifier.
<code>md_name_format</code>	Maintenance Domain Name Format. The default is 4 (Character string)
<code>md_name_length</code>	Maintenance Domain Name Length. (0 means automatically-calculate when encoding.)
<code>md_name</code>	Maintenance Domain Name.
<code>short_ma_name_format</code>	Short MA Name Format. The default is 2 (Character string)
<code>short_ma_name_length</code>	Short MA Name Format Length. (0 means automatically-calculate when encoding.)
<code>short_ma_name</code>	Short MA Name.
<code>tlvs</code>	TLVs.

class `ryu.lib.packet.cfm.cfm` (*op=None*)
 CFM (Connectivity Fault Management) Protocol header class.

<http://standards.ieee.org/getieee802/download/802.1ag-2007.pdf>

OpCode Field range assignments

OpCode range	CFM PDU or organization
0	Reserved for IEEE 802.1
1	Continuity Check Message (CCM)
2	Loopback Reply (LBR)
3	Loopback Message (LBM)
4	Linktrace Reply (LTR)
5	Linktrace Message (LTM)
06 - 31	Reserved for IEEE 802.1
32 - 63	Defined by ITU-T Y.1731
64 - 255	Reserved for IEEE 802.1.

An instance has the following attributes at least. Most of them are same to the on-wire counterparts but in host byte order. `__init__` takes the corresponding args in this order.

Attribute	Description
<code>op</code>	CFM PDU

class `ryu.lib.packet.cfm.data_tlv` (*length=0, data_value=''*)
 CFM (IEEE Std 802.1ag-2007) Data TLV encoder/decoder class.

This is used with `ryu.lib.packet.cfm.cfm`.

An instance has the following attributes at least. Most of them are same to the on-wire counterparts but in host byte order. `__init__` takes the corresponding args in this order.

Attribute	Description
<code>length</code>	Length of Value field. (0 means automatically-calculate when encoding)
<code>data_value</code>	Bit pattern of any of n octets.(n = length)

class `ryu.lib.packet.cfm.interface_status_tlv` (*length=0, interface_status=1*)
 CFM (IEEE Std 802.1ag-2007) Interface Status TLV encoder/decoder class.

This is used with `ryu.lib.packet.cfm.cfm`.

An instance has the following attributes at least. Most of them are same to the on-wire counterparts but in host byte order. `__init__` takes the corresponding args in this order.

Attribute	Description
<code>length</code>	Length of Value field. (0 means automatically-calculate when encoding.)
<code>interface_status</code>	Interface Status. The default is 1 (isUp)

```
class ryu.lib.packet.cfm.link_trace_message (md_lv=0, version=0, use_fdb_only=1,
                                             transaction_id=0, ttl=64,
                                             ltm_orig_addr='00:00:00:00:00:00',
                                             ltm_targ_addr='00:00:00:00:00:00',
                                             tlvs=None)
```

CFM (IEEE Std 802.1ag-2007) Linktrace Message (LTM) encoder/decoder class.

This is used with `ryu.lib.packet.cfm.cfm`.

An instance has the following attributes at least. Most of them are same to the on-wire counterparts but in host byte order. `__init__` takes the corresponding args in this order.

Attribute	Description
<code>md_lv</code>	Maintenance Domain Level.
<code>version</code>	The protocol version number.
<code>use_fdb_only</code>	UseFDBOnly bit.
<code>transaction_id</code>	LTM Transaction Identifier.
<code>ttl</code>	LTM TTL.
<code>ltm_orig_addr</code>	Original MAC Address.
<code>ltm_targ_addr</code>	Target MAC Address.
<code>tlvs</code>	TLVs.

```
class ryu.lib.packet.cfm.link_trace_reply (md_lv=0, version=0, use_fdb_only=1, fwd_yes=0,
                                           terminal_mep=1, transaction_id=0, ttl=64, relay_action=1, tlvs=None)
```

CFM (IEEE Std 802.1ag-2007) Linktrace Reply (LTR) encoder/decoder class.

This is used with `ryu.lib.packet.cfm.cfm`.

An instance has the following attributes at least. Most of them are same to the on-wire counterparts but in host byte order. `__init__` takes the corresponding args in this order.

Attribute	Description
<code>version</code>	The protocol version number.
<code>use_fdb_only</code>	UseFDBOnly bit.
<code>fwd_yes</code>	FwdYes bit.
<code>terminal_mep</code>	TerminalMep bit.
<code>transaction_id</code>	LTR Transaction Identifier.
<code>ttl</code>	Reply TTL.
<code>relay_action</code>	Relay Action. The default is 1 (RlyHit)
<code>tlvs</code>	TLVs.

```
class ryu.lib.packet.cfm.loopback_message (md_lv=0, version=0, transaction_id=0,
                                           tlvs=None)
```

CFM (IEEE Std 802.1ag-2007) Loopback Message (LBM) encoder/decoder class.

This is used with `ryu.lib.packet.cfm.cfm`.

An instance has the following attributes at least. Most of them are same to the on-wire counterparts but in host byte order. `__init__` takes the corresponding args in this order.

Attribute	Description
md_lv	Maintenance Domain Level.
version	The protocol version number.
transaction_id	Loopback Transaction Identifier.
tlvs	TLVs.

class `ryu.lib.packet.cfm.loopback_reply` (*md_lv=0, version=0, transaction_id=0, tlvs=None*)
CFM (IEEE Std 802.1ag-2007) Loopback Reply (LBR) encoder/decoder class.

This is used with `ryu.lib.packet.cfm.cfm`.

An instance has the following attributes at least. Most of them are same to the on-wire counterparts but in host byte order. `__init__` takes the corresponding args in this order.

Attribute	Description
md_lv	Maintenance Domain Level.
version	The protocol version number.
transaction_id	Loopback Transaction Identifier.
tlvs	TLVs.

class `ryu.lib.packet.cfm.ltm_egress_identifier_tlv` (*length=0, egress_id_ui=0, egress_id_mac='00:00:00:00:00:00'*)
CFM (IEEE Std 802.1ag-2007) LTM EGRESS TLV encoder/decoder class.

This is used with `ryu.lib.packet.cfm.cfm`.

An instance has the following attributes at least. Most of them are same to the on-wire counterparts but in host byte order. `__init__` takes the corresponding args in this order.

Attribute	Description
length	Length of Value field. (0 means automatically-calculate when encoding.)
egress_id_ui	Egress Identifier of Unique ID.
egress_id_mac	Egress Identifier of MAC address.

class `ryu.lib.packet.cfm.ltr_egress_identifier_tlv` (*length=0, last_egress_id_ui=0, last_egress_id_mac='00:00:00:00:00:00', next_egress_id_ui=0, next_egress_id_mac='00:00:00:00:00:00'*)
CFM (IEEE Std 802.1ag-2007) LTR EGRESS TLV encoder/decoder class.

This is used with `ryu.lib.packet.cfm.cfm`.

An instance has the following attributes at least. Most of them are same to the on-wire counterparts but in host byte order. `__init__` takes the corresponding args in this order.

Attribute	Description
length	Length of Value field. (0 means automatically-calculate when encoding.)
last_egress_id_ui	Last Egress Identifier of Unique ID.
last_egress_id_mac	Last Egress Identifier of MAC address.
next_egress_id_ui	Next Egress Identifier of Unique ID.
next_egress_id_mac	Next Egress Identifier of MAC address.

class `ryu.lib.packet.cfm.organization_specific_tlv` (*length=0, oui='x00x00x00', subtype=0, value=''*)

CFM (IEEE Std 802.1ag-2007) Organization Specific TLV encoder/decoder class.

This is used with `ryu.lib.packet.cfm.cfm`.

An instance has the following attributes at least. Most of them are same to the on-wire counterparts but in host byte order. `__init__` takes the corresponding args in this order.

Attribute	Description
length	Length of Value field. (0 means automatically-calculate when encoding.)
oui	Organizationally Unique Identifier.
subtype	Subtype.
value	Value.(optional)

class `ryu.lib.packet.cfm.port_status_tlv` (*length=0, port_status=2*)
CFM (IEEE Std 802.1ag-2007) Port Status TLV encoder/decoder class.

This is used with `ryu.lib.packet.cfm.cfm`.

An instance has the following attributes at least. Most of them are same to the on-wire counterparts but in host byte order. `__init__` takes the corresponding args in this order.

Attribute	Description
length	Length of Value field. (0 means automatically-calculate when encoding.)
port_status	Port Status.The default is 1 (psUp)

class `ryu.lib.packet.cfm.reply_egress_tlv` (*length=0, action=1, mac_address='00:00:00:00:00:00', port_id_length=0, port_id_subtype=0, port_id=''*)
CFM (IEEE Std 802.1ag-2007) Reply Egress TLV encoder/decoder class.

This is used with `ryu.lib.packet.cfm.cfm`.

An instance has the following attributes at least. Most of them are same to the on-wire counterparts but in host byte order. `__init__` takes the corresponding args in this order.

Attribute	Description
length	Length of Value field. (0 means automatically-calculate when encoding.)
action	Egress Action.The default is 1 (EgrOK)
mac_address	Egress MAC Address.
port_id_length	Egress PortID Length. (0 means automatically-calculate when encoding.)
port_id_subtype	Egress PortID Subtype.
port_id	Egress PortID.

class `ryu.lib.packet.cfm.reply_ingress_tlv` (*length=0, action=1, mac_address='00:00:00:00:00:00', port_id_length=0, port_id_subtype=0, port_id=''*)
CFM (IEEE Std 802.1ag-2007) Reply Ingress TLV encoder/decoder class.

This is used with `ryu.lib.packet.cfm.cfm`.

An instance has the following attributes at least. Most of them are same to the on-wire counterparts but in host byte order. `__init__` takes the corresponding args in this order.

Attribute	Description
length	Length of Value field. (0 means automatically-calculate when encoding.)
action	Ingress Action.The default is 1 (IngOK)
mac_address	Ingress MAC Address.
port_id_length	Ingress PortID Length. (0 means automatically-calculate when encoding.)
port_id_subtype	Ingress PortID Subtype.
port_id	Ingress PortID.

class `ryu.lib.packet.cfm.sender_id_tlv` (*length=0, chassis_id_length=0, chassis_id_subtype=4, chassis_id='', ma_domain_length=0, ma_domain='', ma_length=0, ma=''*)
CFM (IEEE Std 802.1ag-2007) Sender ID TLV encoder/decoder class.

This is used with `ryu.lib.packet.cfm.cfm`.

An instance has the following attributes at least. Most of them are same to the on-wire counterparts but in host byte order. `__init__` takes the corresponding args in this order.

Attribute	Description
<code>length</code>	Length of Value field. (0 means automatically-calculate when encoding.)
<code>chassis_id_length</code>	Chassis ID Length. (0 means automatically-calculate when encoding.)
<code>chassis_id_subtype</code>	Chassis ID Subtype. The default is 4 (Mac Address)
<code>chassis_id</code>	Chassis ID.
<code>ma_domain_length</code>	Management Address Domain Length. (0 means automatically-calculate when encoding.)
<code>ma_domain</code>	Management Address Domain.
<code>ma_length</code>	Management Address Length. (0 means automatically-calculate when encoding.)
<code>ma</code>	Management Address.

class `ryu.lib.packet.tcp.tcp` (*src_port=1, dst_port=1, seq=0, ack=0, offset=0, bits=0, window_size=0, csum=0, urgent=0, option=None*)
 TCP (RFC 793) header encoder/decoder class.

An instance has the following attributes at least. Most of them are same to the on-wire counterparts but in host byte order. `__init__` takes the corresponding args in this order.

Attribute	Description
<code>src_port</code>	Source Port
<code>dst_port</code>	Destination Port
<code>seq</code>	Sequence Number
<code>ack</code>	Acknowledgement Number
<code>offset</code>	Data Offset (0 means automatically-calculate when encoding)
<code>bits</code>	Control Bits
<code>window_size</code>	Window
<code>csum</code>	Checksum (0 means automatically-calculate when encoding)
<code>urgent</code>	Urgent Pointer
<code>option</code>	List of <code>TCPOption</code> sub-classes or a bytearray containing options. None if no options.

class `ryu.lib.packet.udp.udp` (*src_port=1, dst_port=1, total_length=0, csum=0*)
 UDP (RFC 768) header encoder/decoder class.

An instance has the following attributes at least. Most of them are same to the on-wire counterparts but in host byte order. `__init__` takes the corresponding args in this order.

Attribute	Description
<code>src_port</code>	Source Port
<code>dst_port</code>	Destination Port
<code>total_length</code>	Length (0 means automatically-calculate when encoding)
<code>csum</code>	Checksum (0 means automatically-calculate when encoding)

class `ryu.lib.packet.dhcp.dhcp` (*op, chaddr, options, htype=1, hlen=0, hops=0, xid=None, secs=0, flags=0, ciaddr='0.0.0.0', yiaddr='0.0.0.0', siaddr='0.0.0.0', giaddr='0.0.0.0', sname='', boot_file=''*)
 DHCP (RFC 2131) header encoder/decoder class.

The serialized packet would looks like the ones described in the following sections.

- RFC 2131 DHCP packet format

An instance has the following attributes at least. Most of them are same to the on-wire counterparts but in host byte order. `__init__` takes the corresponding args in this order.

Attribute	Description
op	Message op code / message type. 1 = BOOTREQUEST, 2 = BOOTREPLY
htype	Hardware address type (e.g. '1' = 10mb ethernet).
hlen	Hardware address length (e.g. '6' = 10mb ethernet).
hops	Client sets to zero, optionally used by relay agent when booting via a relay agent.
xid	Transaction ID, a random number chosen by the client, used by the client and server to associate messages and responses between a client and a server.
secs	Filled in by client, seconds elapsed since client began address acquisition or renewal process.
flags	Flags.
ciaddr	Client IP address; only filled in if client is in BOUND, RENEW or REBINDING state and can respond to ARP requests.
yiaddr	'your' (client) IP address.
siaddr	IP address of next server to use in bootstrap; returned in DHCPOFFER, DHCPACK by server.
giaddr	Relay agent IP address, used in booting via a relay agent.
chaddr	Client hardware address.
sname	Optional server host name, null terminated string.
boot_file	Boot file name, null terminated string; "generic" name or null in DHCPDISCOVER, fully qualified directory-path name in DHCPOFFER.
options	Optional parameters field ('DHCP message type' option must be included in every DHCP message).

class `ryu.lib.packet.dhcp.options` (*option_list=None, options_len=0, magic_cookie='99.130.83.99'*)

DHCP (RFC 2132) options encoder/decoder class.

This is used with `ryu.lib.packet.dhcp.dhcp`.

An instance has the following attributes at least. Most of them are same to the on-wire counterparts but in host byte order. `__init__` takes the corresponding args in this order.

Attribute	Description
option_list	'end option' and 'pad option' are added automatically after the option class is stored in array.
options_len	Option's byte length. ('magic cookie', 'end option' and 'pad option' length including.)
magic_cookie	The first four octets contain the decimal values 99, 130, 83 and 99.

class `ryu.lib.packet.dhcp.option` (*tag, value, length=0*)

DHCP (RFC 2132) options encoder/decoder class.

This is used with `ryu.lib.packet.dhcp.dhcp.options`.

An instance has the following attributes at least. Most of them are same to the on-wire counterparts but in host byte order. `__init__` takes the corresponding args in this order.

Attribute	Description
tag	Option type. (except for the 'magic cookie', 'pad option' and 'end option'.)
value	Option's value. (set the value that has been converted to hexadecimal.)
length	Option's value length. (calculated automatically from the length of value.)

class `ryu.lib.packet.vrrp.vrrp` (*version, type_, vrid, priority, count_ip, max_adver_int, checksum, ip_addresses, auth_type=None, auth_data=None*)

The base class for VRRPv2 (RFC 3768) and VRRPv3 (RFC 5798) header encoder/decoder classes.

Unlike other `ryu.lib.packet.packet_base.PacketBase` derived classes, This class should not be directly instantiated by user.

An instance has the following attributes at least. Most of them are same to the on-wire counterparts but in host byte order.

Attribute	Description
version	Version
type	Type
vrid	Virtual Rtr ID (VRID)
priority	Priority
count_ip	Count IPvX Addr. Calculated automatically when encoding.
max_adver_int	Maximum Advertisement Interval (Max Adver Int)
checksum	Checksum. Calculated automatically when encoding.
ip_addresses	IPvX Address(es). A python list of IP addresses.
auth_type	Authentication Type (only for VRRPv2)
auth_data	Authentication Data (only for VRRPv2)

create_packet (*primary_ip_address, vlan_id=None*)

Prepare a VRRP packet.

Returns a newly created `ryu.lib.packet.packet.Packet` object with appropriate protocol header objects added by `add_protocol()`. It's caller's responsibility to `serialize()`. The serialized packet would look like the ones described in the following sections.

- RFC 3768 5.1. VRRP Packet Format
- RFC 5798 5.1. VRRP Packet Format

Argument	Description
primary_ip_address	Source IP address
vlan_id	VLAN ID. None for no VLAN.

class `ryu.lib.packet.vrrp.vrrpv2` (*version, type_, vrid, priority, count_ip, max_adver_int, checksum, ip_addresses, auth_type=None, auth_data=None*)
VRRPv2 (RFC 3768) header encoder/decoder class.

Unlike other `ryu.lib.packet.packet_base.PacketBase` derived classes, *create* method should be used to instantiate an object of this class.

static create (*type_, vrid, priority, max_adver_int, ip_addresses*)

Unlike other `ryu.lib.packet.packet_base.PacketBase` derived classes, this method should be used to instantiate an object of this class.

This method's arguments are same as `ryu.lib.packet.vrrp.vrrp` object's attributes of the same name. (except that *type_* corresponds to *type* attribute.)

class `ryu.lib.packet.vrrp.vrrpv3` (*version, type_, vrid, priority, count_ip, max_adver_int, checksum, ip_addresses, auth_type=None, auth_data=None*)
VRRPv3 (RFC 5798) header encoder/decoder class.

Unlike other `ryu.lib.packet.packet_base.PacketBase` derived classes, *create* method should be used to instantiate an object of this class.

static create (*type_, vrid, priority, max_adver_int, ip_addresses*)

Unlike other `ryu.lib.packet.packet_base.PacketBase` derived classes, this method should be used to instantiate an object of this class.

This method's arguments are same as `ryu.lib.packet.vrrp.vrrp` object's attributes of the same name. (except that *type_* corresponds to *type* attribute.)

class `ryu.lib.packet.slow.slow`
Slow Protocol header decoder class. This class has only the parser method.

http://standards.ieee.org/getieee802/download/802.3-2012_section5.pdf

Slow Protocols Subtypes

Subtype Value	Protocol Name
0	Unused - Illegal Value
1	Link Aggregation Control Protocol(LACP)
2	Link Aggregation - Marker Protocol
3	Operations, Administration, and Maintenance(OAM)
4 - 9	Reserved for future use
10	Organization Specific Slow Protocol(OSSP)
11 - 255	Unused - Illegal values

```
class ryu.lib.packet.slow.lacp (version=1, actor_system_priority=0, actor_system='00:00:00:00:00:00', actor_key=0, actor_port_priority=0, actor_port=0, actor_state_activity=0, actor_state_timeout=0, actor_state_aggregation=0, actor_state_synchronization=0, actor_state_collecting=0, actor_state_distributing=0, actor_state_defaulted=0, actor_state_expired=0, partner_system_priority=0, partner_system='00:00:00:00:00:00', partner_key=0, partner_port_priority=0, partner_port=0, partner_state_activity=0, partner_state_timeout=0, partner_state_aggregation=0, partner_state_synchronization=0, partner_state_collecting=0, partner_state_distributing=0, partner_state_defaulted=0, partner_state_expired=0, collector_max_delay=0)
```

Link Aggregation Control Protocol(LACP, IEEE 802.1AX) header encoder/decoder class.

<http://standards.ieee.org/getieee802/download/802.1AX-2008.pdf>

LACPDU format

LACPDU structure		Octets
Subtype = LACP		1
Version Number		1
TLV Actor	TLV_type = Actor Information	1
	Actor_Information_Length = 20	1
	Actor_System_Priority	2
	Actor_System	6
	Actor_Key	2
	Actor_Port_Priority	2
	Actor_Port	2
	Actor_State	1
	Reserved	3
TLV Partner	TLV_type = Partner Information	1
	Partner_Information_Length = 20	1
	Partner_System_Priority	2
	Partner_System	6
	Partner_Key	2
	Partner_Port_Priority	2
	Partner_Port	2
	Partner_State	1
	Reserved	3
TLV Collector	TLV_type = Collector Information	1
	Collector_Information_Length = 16	1
	Collector_Max_Delay	2
	Reserved	12
TLV Terminator	TLV_type = Terminator	1
	Terminator_Length = 0	1
	Reserved	50

Terminator information uses a length value of 0 (0x00).

NOTE—The use of a Terminator Length of 0 is intentional. In TLV encoding schemes it is common practice for the terminator encoding to be 0 both for the type and the length.

Actor_State and Partner_State encoded as individual bits within a single octet as follows:

7	6	5	4	3	2	1	0
EXPR	DFLT	DIST	CLCT	SYNC	AGGR	TMO	ACT

ACT bit 0. about the activity control value with regard to this link.

TMO bit 1. about the timeout control value with regard to this link.

AGGR bit 2. about how the system regards this link from the point of view of the aggregation.

SYNC bit 3. about how the system regards this link from the point of view of the synchronization.

CLCT bit 4. about collecting of incoming frames.

DIST bit 5. about distributing of outgoing frames.

DFLT bit 6. about the opposite system information which the system use.

EXPR bit 7. about the expire state of the system.

An instance has the following attributes at least. Most of them are same to the on-wire counterparts but in host byte order. `__init__` takes the corresponding args in this order.

Attribute	Description
version	LACP version. This parameter must be set to LACP_VERSION_NUMBER(i.e. 1).
actor_system_priority	The priority assigned to this System.
actor_system	The Actor's System ID, encoded as a MAC address.
actor_key	The operational Key value assigned to the port by the Actor.
actor_port_priority	The priority assigned to this port.
actor_port	The port number assigned to the port by the Actor.
actor_state_activity	about the activity control value with regard to this link. LACP_STATE_ACTIVE(1) LACP_STATE_PASSIVE(0)
actor_state_timeout	about the timeout control value with regard to this link. LACP_STATE_SHORT_TIMEOUT(1) LACP_STATE_LONG_TIMEOUT(0)
actor_state_aggregation	about how the system regards this link from the point of view of the aggregation. LACP_STATE_AGGREGATEABLE(1) LACP_STATE_INDIVIDUAL(0)
actor_state_synchronization	about how the system regards this link from the point of view of the synchronization. LACP_STATE_IN_SYNC(1) LACP_STATE_OUT_OF_SYNC(0)
actor_state_collecting	about collecting of incoming frames. LACP_STATE_COLLECTING_ENABLED(1) LACP_STATE_COLLECTING_DISABLED(0)
actor_state_distributing	about distributing of outgoing frames. LACP_STATE_DISTRIBUTING_ENABLED(1) LACP_STATE_DISTRIBUTING_DISABLED(0)
actor_state_defaulted	about the Partner information which the the Actor use. LACP_STATE_DEFAULTED_PARTNER(1) LACP_STATE_OPERATIONAL_PARTNER(0)
actor_state_expired	about the state of the Actor. LACP_STATE_EXPIRED(1) LACP_STATE_NOT_EXPIRED(0)
partner_system_priority	The priority assigned to the Partner System.
partner_system	The Partner's System ID, encoded as a MAC address.
partner_key	The operational Key value assigned to the port by the Partner.
partner_port_priority	The priority assigned to this port by the Partner.
partner_port	The port number assigned to the port by the Partner.
partner_state_activity	See <i>actor_state_activity</i> .
partner_state_timeout	See <i>actor_state_timeout</i> .
partner_state_aggregation	See <i>actor_state_aggregation</i> .
partner_state_synchronization	See <i>actor_state_synchronization</i> .
partner_state_collecting	See <i>actor_state_collecting</i> .
partner_state_distributing	See <i>actor_state_distributing</i> .
partner_state_defaulted	See <i>actor_state_defaulted</i> .
partner_state_expired	See <i>actor_state_expired</i> .
collector_max_delay	the maximum time that the Frame Collector may delay.

class `ryu.lib.packet.llc.llc` (*dsap_addr, ssap_addr, control*)
 LLC(IEEE 802.2) header encoder/decoder class.

An instance has the following attributes at least. Most of them are same to the on-wire counterparts but in host byte order. `__init__` takes the corresponding args in this order.

Attribute	Description
<code>dsap_addr</code>	Destination service access point address field includes I/G bit at least significant bit.
<code>ssap_addr</code>	Source service access point address field includes C/R bit at least significant bit.
<code>control</code>	Control field [16 bits for formats that include sequence numbering, and 8 bits for formats that do not]. Either <code>ryu.lib.packet.llc.ControlFormatI</code> or <code>ryu.lib.packet.llc.ControlFormatS</code> or <code>ryu.lib.packet.llc.ControlFormatU</code> object.

class `ryu.lib.packet.llc.ControlFormatI` (*send_sequence_number=0, pf_bit=0, receive_sequence_number=0*)
 LLC sub encoder/decoder class for control I-format field.

An instance has the following attributes at least. Most of them are same to the on-wire counterparts but in host byte order. `__init__` takes the corresponding args in this order.

Attribute	Description
<code>send_sequence_number</code>	sender send sequence number
<code>pf_bit</code>	poll/final bit
<code>receive_sequence_number</code>	sender receive sequence number

class `ryu.lib.packet.llc.ControlFormatS` (*supervisory_function=0, pf_bit=0, receive_sequence_number=0*)
 LLC sub encoder/decoder class for control S-format field.

An instance has the following attributes at least. Most of them are same to the on-wire counterparts but in host byte order. `__init__` takes the corresponding args in this order.

Attribute	Description
<code>supervisory_function</code>	supervisory function bit
<code>pf_bit</code>	poll/final bit
<code>receive_sequence_number</code>	sender receive sequence number

class `ryu.lib.packet.llc.ControlFormatU` (*modifier_function1=0, pf_bit=0, modifier_function2=0*)
 LLC sub encoder/decoder class for control U-format field.

An instance has the following attributes at least. Most of them are same to the on-wire counterparts but in host byte order. `__init__` takes the corresponding args in this order.

Attribute	Description
<code>modifier_function1</code>	modifier function bit
<code>pf_bit</code>	poll/final bit
<code>modifier_function2</code>	modifier function bit

class `ryu.lib.packet.bpdu.bpdu`
 Bridge Protocol Data Unit(BPDU) header encoder/decoder base class.

class `ryu.lib.packet.bpdu.ConfigurationBPDU` (*flags=0, root_priority=32768, root_system_id_extension=0, root_mac_address='00:00:00:00:00:00', root_path_cost=0, bridge_priority=32768, bridge_system_id_extension=0, bridge_mac_address='00:00:00:00:00:00', port_priority=128, port_number=0, message_age=0, max_age=20, hello_time=2, forward_delay=15*)

Configuration BPDUs(IEEE 802.1D) header encoder/decoder class.

An instance has the following attributes at least. Most of them are same to the on-wire counterparts but in host byte order. `__init__` takes the corresponding args in this order.

Attribute	Description
flags	Bit 1: Topology Change flag Bits 2 through 7: unused and take the value 0 Bit 8: Topology Change Acknowledgment flag
root_priority	Root Identifier priority set 0-61440 in steps of 4096
root_system_id_extension	Root Identifier system ID extension
root_mac_address	Root Identifier MAC address
root_path_cost	Root Path Cost
bridge_priority	Bridge Identifier priority set 0-61440 in steps of 4096
bridge_system_id_extension	Bridge Identifier system ID extension
bridge_mac_address	Bridge Identifier MAC address
port_priority	Port Identifier priority set 0-240 in steps of 16
port_number	Port Identifier number
message_age	Message Age timer value
max_age	Max Age timer value
hello_time	Hello Time timer value
forward_delay	Forward Delay timer value

class `ryu.lib.packet.bpdu.TopologyChangeNotificationBPDUs`
Topology Change Notification BPDUs(IEEE 802.1D) header encoder/decoder class.

class `ryu.lib.packet.bpdu.RstBPDUs` (*flags=0, root_priority=32768, root_system_id_extension=0, root_mac_address='00:00:00:00:00:00', root_path_cost=0, bridge_priority=32768, bridge_system_id_extension=0, bridge_mac_address='00:00:00:00:00:00', port_priority=128, port_number=0, message_age=0, max_age=20, hello_time=2, forward_delay=15*)

Rapid Spanning Tree BPDUs(RST BPDUs, IEEE 802.1D) header encoder/decoder class.

An instance has the following attributes at least. Most of them are same to the on-wire counterparts but in host byte order. `__init__` takes the corresponding args in this order.

Attribute	Description
flags	Bit 1: Topology Change flag Bit 2: Proposal flag Bits 3 and 4: Port Role Bit 5: Learning flag Bit 6: Forwarding flag Bit 7: Agreement flag Bit 8: Topology Change Acknowledgment flag
root_priority	Root Identifier priority set 0-61440 in steps of 4096
root_system_id_extension	Root Identifier system ID extension
root_mac_address	Root Identifier MAC address
root_path_cost	Root Path Cost
bridge_priority	Bridge Identifier priority set 0-61440 in steps of 4096
bridge_system_id_extension	Bridge Identifier system ID extension
bridge_mac_address	Bridge Identifier MAC address
port_priority	Port Identifier priority set 0-240 in steps of 16
port_number	Port Identifier number
message_age	Message Age timer value
max_age	Max Age timer value
hello_time	Hello Time timer value
forward_delay	Forward Delay timer value

class `ryu.lib.packet.igmp.igmp` (*msgtype=17, maxresp=0, csum=0, address='0.0.0.0'*)
 Internet Group Management Protocol(IGMP, RFC 1112, RFC 2236) header encoder/decoder class.

<http://www.ietf.org/rfc/rfc1112.txt>

<http://www.ietf.org/rfc/rfc2236.txt>

An instance has the following attributes at least. Most of them are same to the on-wire counterparts but in host byte order. `__init__` takes the corresponding args in this order.

Attribute	Description
msgtype	a message type for v2, or a combination of version and a message type for v1.
maxresp	max response time in unit of 1/10 second. it is meaningful only in Query Message.
csum	a check sum value. 0 means automatically-calculate when encoding.
address	a group address value.

class `ryu.lib.packet.igmp.igmpv3_query` (*msgtype=17, maxresp=100, csum=0, address='0.0.0.0', s_flg=0, qrv=2, qqic=0, num=0, srcs=None*)
 Internet Group Management Protocol(IGMP, RFC 3376) Membership Query message encoder/decoder class.

<http://www.ietf.org/rfc/rfc3376.txt>

An instance has the following attributes at least. Most of them are same to the on-wire counterparts but in host byte order. `__init__` takes the corresponding args in this order.

Attribute	Description
msgtype	a message type for v3.
maxresp	max response time in unit of 1/10 second.
csum	a check sum value. 0 means automatically-calculate when encoding.
address	a group address value.
s_flg	when set to 1, routers suppress the timer process.
qrv	robustness variable for a querier.
qqic	an interval time for a querier in unit of seconds.
num	a number of the multicast servers.
srcs	a list of IPv4 addresses of the multicast servers.

class `ryu.lib.packet.igmp.igmpv3_report` (*msgtype=34, csum=0, record_num=0, records=None*)

Internet Group Management Protocol(IGMP, RFC 3376) Membership Report message encoder/decoder class.

<http://www.ietf.org/rfc/rfc3376.txt>

An instance has the following attributes at least. Most of them are same to the on-wire counterparts but in host byte order. `__init__` takes the corresponding args in this order.

Attribute	Description
msgtype	a message type for v3.
csum	a check sum value. 0 means automatically-calculate when encoding.
record_num	a number of the group records.
records	a list of <code>ryu.lib.packet.igmp.igmpv3_report_group</code> . None if no records.

class `ryu.lib.packet.igmp.igmpv3_report_group` (*type_=0, aux_len=0, num=0, address='0.0.0.0', srcs=None, aux=None*)

Internet Group Management Protocol(IGMP, RFC 3376) Membership Report Group Record message encoder/decoder class.

<http://www.ietf.org/rfc/rfc3376.txt>

This is used with `ryu.lib.packet.igmp.igmpv3_report`.

An instance has the following attributes at least. Most of them are same to the on-wire counterparts but in host byte order. `__init__` takes the corresponding args in this order.

Attribute	Description
type_	a group record type for v3.
aux_len	the length of the auxiliary data.
num	a number of the multicast servers.
address	a group address value.
srcs	a list of IPv4 addresses of the multicast servers.
aux	the auxiliary data.

class `ryu.lib.packet.bgp.BGPMessage` (*type_, len_=None, marker=None*)

Base class for BGP-4 messages.

An instance has the following attributes at least. Most of them are same to the on-wire counterparts but in host byte order. `__init__` takes the corresponding args in this order.

Attribute	Description
marker	Marker field. Ignored when encoding.
len	Length field. Ignored when encoding.
type	Type field. one of <code>BGP_MSG_constants</code> .

class `ryu.lib.packet.bgp.BGPOpen` (*my_as, bgp_identifier, type_=1, opt_param_len=0, opt_param=None, version=4, hold_time=0, len_=None, marker=None*)

BGP-4 OPEN Message encoder/decoder class.

An instance has the following attributes at least. Most of them are same to the on-wire counterparts but in host byte order. `__init__` takes the corresponding args in this order.

Attribute	Description
marker	Marker field. Ignored when encoding.
len	Length field. Ignored when encoding.
type	Type field. The default is BGP_MSG_OPEN.
version	Version field. The default is 4.
my_as	My Autonomous System field. 2 octet unsigned integer.
hold_time	Hold Time field. 2 octet unsigned integer. The default is 0.
bgp_identifier	BGP Identifier field. An IPv4 address. For example, '192.0.2.1'
opt_param_len	Optional Parameters Length field. Ignored when encoding.
opt_param	Optional Parameters field. A list of BGPOptParam instances. The default is [].

```
class ryu.lib.packet.bgp.BGPUpdate (type_=2,          withdrawn_routes_len=None,          with-
                                   drawn_routes=None,          total_path_attribute_len=None,
                                   path_attributes=None,          nlri=None,          len_=None,
                                   marker=None)
```

BGP-4 UPDATE Message encoder/decoder class.

An instance has the following attributes at least. Most of them are same to the on-wire counterparts but in host byte order. `__init__` takes the corresponding args in this order.

Attribute	Description
marker	Marker field. Ignored when encoding.
len	Length field. Ignored when encoding.
type	Type field. The default is BGP_MSG_UPDATE.
withdrawn_routes_len	Withdrawn Routes Length field. Ignored when encoding.
withdrawn_routes	Withdrawn Routes field. A list of BGPWithdrawnRoute instances. The default is [].
total_path_attribute_len	Total Path Attribute Length field. Ignored when encoding.
path_attributes	Path Attributes field. A list of BGPPathAttribute instances. The default is [].
nlri	Network Layer Reachability Information field. A list of BGPNLRI instances. The default is [].

```
class ryu.lib.packet.bgp.BGPKeepAlive (type_=4, len_=None, marker=None)
BGP-4 KEEPALIVE Message encoder/decoder class.
```

An instance has the following attributes at least. Most of them are same to the on-wire counterparts but in host byte order. `__init__` takes the corresponding args in this order.

Attribute	Description
marker	Marker field. Ignored when encoding.
len	Length field. Ignored when encoding.
type	Type field. The default is BGP_MSG_KEEPALIVE.

```
class ryu.lib.packet.bgp.BGPNotification (error_code, error_subcode, data='', type_=3,
                                          len_=None, marker=None)
BGP-4 NOTIFICATION Message encoder/decoder class.
```

An instance has the following attributes at least. Most of them are same to the on-wire counterparts but in host byte order. `__init__` takes the corresponding args in this order.

Attribute	Description
marker	Marker field. Ignored when encoding.
len	Length field. Ignored when encoding.
type	Type field. The default is BGP_MSG_NOTIFICATION.
error_code	Error code field.
error_subcode	Error subcode field.
data	Data field. The default is ''.

class `ryu.lib.packet.sctp.cause_cookie_while_shutdown` (*length=0*)
 Stream Control Transmission Protocol (SCTP) sub encoder/decoder class for Cookie Received While Shutting Down (RFC 4960).

This is used with `ryu.lib.packet.sctp.chunk_abort` and `ryu.lib.packet.sctp.chunk_error`.

An instance has the following attributes at least. Most of them are same to the on-wire counterparts but in host byte order. `__init__` takes the corresponding args in this order.

Attribute	Description
length	length of this cause containing this header. (0 means automatically-calculate when encoding)

class `ryu.lib.packet.sctp.cause_invalid_param` (*length=0*)
 Stream Control Transmission Protocol (SCTP) sub encoder/decoder class for Invalid Mandatory Parameter (RFC 4960).

This is used with `ryu.lib.packet.sctp.chunk_abort` and `ryu.lib.packet.sctp.chunk_error`.

An instance has the following attributes at least. Most of them are same to the on-wire counterparts but in host byte order. `__init__` takes the corresponding args in this order.

Attribute	Description
length	length of this cause containing this header. (0 means automatically-calculate when encoding)

class `ryu.lib.packet.sctp.cause_invalid_stream_id` (*value=0, length=0*)
 Stream Control Transmission Protocol (SCTP) sub encoder/decoder class for Invalid Stream Identifier (RFC 4960).

This is used with `ryu.lib.packet.sctp.chunk_abort` and `ryu.lib.packet.sctp.chunk_error`.

An instance has the following attributes at least. Most of them are same to the on-wire counterparts but in host byte order. `__init__` takes the corresponding args in this order.

Attribute	Description
value	stream id.
length	length of this cause containing this header. (0 means automatically-calculate when encoding)

class `ryu.lib.packet.sctp.cause_missing_param` (*types=None, num=0, length=0*)
 Stream Control Transmission Protocol (SCTP) sub encoder/decoder class for Missing Mandatory Parameter (RFC 4960).

This is used with `ryu.lib.packet.sctp.chunk_abort` and `ryu.lib.packet.sctp.chunk_error`.

An instance has the following attributes at least. Most of them are same to the on-wire counterparts but in host byte order. `__init__` takes the corresponding args in this order.

Attribute	Description
types	a list of missing params.
num	Number of missing params. (0 means automatically-calculate when encoding)
length	length of this cause containing this header. (0 means automatically-calculate when encoding)

class `ryu.lib.packet.sctp.cause_no_userdata` (*value=None, length=0*)
 Stream Control Transmission Protocol (SCTP) sub encoder/decoder class for No User Data (RFC 4960).

This is used with `ryu.lib.packet.sctp.chunk_abort` and `ryu.lib.packet.sctp.chunk_error`.

An instance has the following attributes at least. Most of them are same to the on-wire counterparts but in host byte order. `__init__` takes the corresponding args in this order.

Attribute	Description
value	the TSN of the DATA chunk received with no user data field.
length	length of this cause containing this header. (0 means automatically-calculate when encoding)

class `ryu.lib.packet.sctp.cause_out_of_resource` (*length=0*)
 Stream Control Transmission Protocol (SCTP) sub encoder/decoder class for Out of Resource (RFC 4960).

This is used with `ryu.lib.packet.sctp.chunk_abort` and `ryu.lib.packet.sctp.chunk_error`.

An instance has the following attributes at least. Most of them are same to the on-wire counterparts but in host byte order. `__init__` takes the corresponding args in this order.

Attribute	Description
length	length of this cause containing this header. (0 means automatically-calculate when encoding)

class `ryu.lib.packet.sctp.cause_protocol_violation` (*value=None, length=0*)
 Stream Control Transmission Protocol (SCTP) sub encoder/decoder class for Protocol Violation (RFC 4960).

This is used with `ryu.lib.packet.sctp.chunk_abort` and `ryu.lib.packet.sctp.chunk_error`.

An instance has the following attributes at least. Most of them are same to the on-wire counterparts but in host byte order. `__init__` takes the corresponding args in this order.

Attribute	Description
value	Additional Information.
length	length of this cause containing this header. (0 means automatically-calculate when encoding)

class `ryu.lib.packet.sctp.cause_restart_with_new_addr` (*value=None, length=0*)
 Stream Control Transmission Protocol (SCTP) sub encoder/decoder class for Restart of an Association with New Addresses (RFC 4960).

This is used with `ryu.lib.packet.sctp.chunk_abort` and `ryu.lib.packet.sctp.chunk_error`.

An instance has the following attributes at least. Most of them are same to the on-wire counterparts but in host byte order. `__init__` takes the corresponding args in this order.

Attribute	Description
value	New Address TLVs.
length	length of this cause containing this header. (0 means automatically-calculate when encoding)

class `ryu.lib.packet.sctp.cause_stale_cookie` (*value=None, length=0*)
 Stream Control Transmission Protocol (SCTP) sub encoder/decoder class for Stale Cookie Error (RFC 4960).

This is used with `ryu.lib.packet.sctp.chunk_abort` and `ryu.lib.packet.sctp.chunk_error`.

An instance has the following attributes at least. Most of them are same to the on-wire counterparts but in host byte order. `__init__` takes the corresponding args in this order.

Attribute	Description
value	Measure of Staleness.
length	length of this cause containing this header. (0 means automatically-calculate when encoding)

class `ryu.lib.packet.sctp.cause_unrecognized_chunk` (*value=None, length=0*)
 Stream Control Transmission Protocol (SCTP) sub encoder/decoder class for Unrecognized Chunk Type (RFC 4960).

This is used with `ryu.lib.packet.sctp.chunk_abort` and `ryu.lib.packet.sctp.chunk_error`.

An instance has the following attributes at least. Most of them are same to the on-wire counterparts but in host byte order. `__init__` takes the corresponding args in this order.

Attribute	Description
value	Unrecognized Chunk.
length	length of this cause containing this header. (0 means automatically-calculate when encoding)

class `ryu.lib.packet.sctp.cause_unrecognized_param` (*value=None, length=0*)
 Stream Control Transmission Protocol (SCTP) sub encoder/decoder class for Unrecognized Parameters (RFC 4960).

This is used with `ryu.lib.packet.sctp.chunk_abort` and `ryu.lib.packet.sctp.chunk_error`.

An instance has the following attributes at least. Most of them are same to the on-wire counterparts but in host byte order. `__init__` takes the corresponding args in this order.

Attribute	Description
value	Unrecognized Parameter.
length	length of this cause containing this header. (0 means automatically-calculate when encoding)

class `ryu.lib.packet.sctp.cause_unresolvable_addr` (*value=None, length=0*)
 Stream Control Transmission Protocol (SCTP) sub encoder/decoder class for Unresolvable Address (RFC 4960).

This is used with `ryu.lib.packet.sctp.chunk_abort` and `ryu.lib.packet.sctp.chunk_error`.

An instance has the following attributes at least. Most of them are same to the on-wire counterparts but in host byte order. `__init__` takes the corresponding args in this order.

Attribute	Description
value	Unresolvable Address. one of follows: <code>ryu.lib.packet.sctp.param_host_addr</code> , <code>ryu.lib.packet.sctp.param_ipv4</code> , or <code>ryu.lib.packet.sctp.param_ipv6</code> .
length	length of this cause containing this header. (0 means automatically-calculate when encoding)

class `ryu.lib.packet.sctp.cause_user_initiated_abort` (*value=None, length=0*)
 Stream Control Transmission Protocol (SCTP) sub encoder/decoder class for User-Initiated Abort (RFC 4960).

This is used with `ryu.lib.packet.sctp.chunk_abort` and `ryu.lib.packet.sctp.chunk_error`.

An instance has the following attributes at least. Most of them are same to the on-wire counterparts but in host byte order. `__init__` takes the corresponding args in this order.

Attribute	Description
value	Upper Layer Abort Reason.
length	length of this cause containing this header. (0 means automatically-calculate when encoding)

class `ryu.lib.packet.sctp.chunk_abort` (*tflag=0, length=0, causes=None*)
 Stream Control Transmission Protocol (SCTP) sub encoder/decoder class for Abort Association (ABORT) chunk (RFC 4960).

This is used with `ryu.lib.packet.sctp.sctp`.

An instance has the following attributes at least. Most of them are same to the on-wire counterparts but in host byte order. `__init__` takes the corresponding args in this order.

Attribute	Description
tflag	'0' means the Verification tag is normal. '1' means the Verification tag is copy of the sender.
length	length of this chunk containing this header. (0 means automatically-calculate when encoding)
causes	a list of derived classes of <code>ryu.lib.packet.sctp.causes</code> .

class `ryu.lib.packet.sctp.chunk_cookie_ack` (*flags=0, length=0*)
 Stream Control Transmission Protocol (SCTP) sub encoder/decoder class for Cookie Acknowledgement (COOKIE ACK) chunk (RFC 4960).

This is used with `ryu.lib.packet.sctp.sctp`.

An instance has the following attributes at least. Most of them are same to the on-wire counterparts but in host byte order. `__init__` takes the corresponding args in this order.

Attribute	Description
flags	set to '0'. this field will be ignored.
length	length of this chunk containing this header. (0 means automatically-calculate when encoding)

class `ryu.lib.packet.sctp.chunk_cookie_echo` (*flags=0, length=0, cookie=None*)
 Stream Control Transmission Protocol (SCTP) sub encoder/decoder class for Cookie Echo (COOKIE ECHO) chunk (RFC 4960).

This is used with `ryu.lib.packet.sctp.sctp`.

An instance has the following attributes at least. Most of them are same to the on-wire counterparts but in host byte order. `__init__` takes the corresponding args in this order.

Attribute	Description
flags	set to '0'. this field will be ignored.
length	length of this chunk containing this header. (0 means automatically-calculate when encoding)
cookie	cookie data.

class `ryu.lib.packet.sctp.chunk_cwr` (*flags=0, length=0, low_tsn=0*)
 Stream Control Transmission Protocol (SCTP) sub encoder/decoder class for CWR chunk (RFC 4960 Appendix A.).

This is used with `ryu.lib.packet.sctp.sctp`.

An instance has the following attributes at least. Most of them are same to the on-wire counterparts but in host byte order. `__init__` takes the corresponding args in this order.

Attribute	Description
flags	set to '0'. this field will be ignored.
length	length of this chunk containing this header. (0 means automatically-calculate when encoding)
low_tsn	the lowest TSN.

class `ryu.lib.packet.sctp.chunk_data` (*unordered=0, begin=0, end=0, length=0, tsn=0, sid=0, seq=0, payload_id=0, payload_data=None*)
 Stream Control Transmission Protocol (SCTP) sub encoder/decoder class for Payload Data (DATA) chunk (RFC 4960).

This is used with `ryu.lib.packet.sctp.sctp`.

An instance has the following attributes at least. Most of them are same to the on-wire counterparts but in host byte order. `__init__` takes the corresponding args in this order.

Attribute	Description
unordered	if set to '1', the receiver ignores the sequence number.
begin	if set to '1', this chunk is the first fragment.
end	if set to '1', this chunk is the last fragment.
length	length of this chunk containing this header. (0 means automatically-calculate when encoding)
tsn	Transmission Sequence Number.
sid	stream id.
seq	the sequence number.
payload_id	application specified protocol id. '0' means that no application id is identified.
payload_data	user data.

class `ryu.lib.packet.sctp.chunk_ecn_echo` (*flags=0, length=0, low_tsn=0*)
 Stream Control Transmission Protocol (SCTP) sub encoder/decoder class for ECN-Echo chunk (RFC 4960 Appendix A.).

This is used with `ryu.lib.packet.sctp.sctp`.

An instance has the following attributes at least. Most of them are same to the on-wire counterparts but in host byte order. `__init__` takes the corresponding args in this order.

Attribute	Description
flags	set to '0'. this field will be ignored.
length	length of this chunk containing this header. (0 means automatically-calculate when encoding)
low_tsn	the lowest TSN.

class `ryu.lib.packet.sctp.chunk_error` (*flags=0, length=0, causes=None*)

Stream Control Transmission Protocol (SCTP) sub encoder/decoder class for Operation Error (ERROR) chunk (RFC 4960).

This is used with `ryu.lib.packet.sctp.sctp`.

An instance has the following attributes at least. Most of them are same to the on-wire counterparts but in host byte order. `__init__` takes the corresponding args in this order.

Attribute	Description
flags	set to '0'. this field will be ignored.
length	length of this chunk containing this header. (0 means automatically-calculate when encoding)
causes	a list of derived classes of <code>ryu.lib.packet.sctp.causes</code> .

class `ryu.lib.packet.sctp.chunk_heartbeat` (*flags=0, length=0, info=None*)

Stream Control Transmission Protocol (SCTP) sub encoder/decoder class for Heartbeat Request (HEARTBEAT) chunk (RFC 4960).

This is used with `ryu.lib.packet.sctp.sctp`.

An instance has the following attributes at least. Most of them are same to the on-wire counterparts but in host byte order. `__init__` takes the corresponding args in this order.

Attribute	Description
flags	set to '0'. this field will be ignored.
length	length of this chunk containing this header. (0 means automatically-calculate when encoding)
info	<code>ryu.lib.packet.sctp.param_heartbeat</code> .

class `ryu.lib.packet.sctp.chunk_heartbeat_ack` (*flags=0, length=0, info=None*)

Stream Control Transmission Protocol (SCTP) sub encoder/decoder class for Heartbeat Acknowledgement (HEARTBEAT ACK) chunk (RFC 4960).

This is used with `ryu.lib.packet.sctp.sctp`.

An instance has the following attributes at least. Most of them are same to the on-wire counterparts but in host byte order. `__init__` takes the corresponding args in this order.

Attribute	Description
flags	set to '0'. this field will be ignored.
length	length of this chunk containing this header. (0 means automatically-calculate when encoding)
info	<code>ryu.lib.packet.sctp.param_heartbeat</code> .

class `ryu.lib.packet.sctp.chunk_init` (*flags=0, length=0, init_tag=0, a_rwnd=0, os=0, mis=0, i_tsn=0, params=None*)

Stream Control Transmission Protocol (SCTP) sub encoder/decoder class for Initiation (INIT) chunk (RFC 4960).

This is used with `ryu.lib.packet.sctp.sctp`.

An instance has the following attributes at least. Most of them are same to the on-wire counterparts but in host byte order. `__init__` takes the corresponding args in this order.

Attribute	Description
flags	set to '0'. this field will be ignored.
length	length of this chunk containing this header. (0 means automatically-calculate when encoding)
init_tag	the tag that be used as Verification Tag.
a_rwnd	Advertised Receiver Window Credit.
os	number of outbound streams.
mis	number of inbound streams.
i_tsn	Transmission Sequence Number that the sender will use.
params	Optional/Variable-Length Parameters. a list of derived classes of <code>ryu.lib.packet.sctp.param</code> .

class `ryu.lib.packet.sctp.chunk_init_ack` (*flags=0, length=0, init_tag=0, a_rwnd=0, os=0, mis=0, i_tsn=0, params=None*)

Stream Control Transmission Protocol (SCTP) sub encoder/decoder class for Initiation Acknowledgement (INIT ACK) chunk (RFC 4960).

This is used with `ryu.lib.packet.sctp.sctp`.

An instance has the following attributes at least. Most of them are same to the on-wire counterparts but in host byte order. `__init__` takes the corresponding args in this order.

Attribute	Description
flags	set to '0'. this field will be ignored.
length	length of this chunk containing this header. (0 means automatically-calculate when encoding)
init_tag	the tag that be used as Verification Tag.
a_rwnd	Advertised Receiver Window Credit.
os	number of outbound streams.
mis	number of inbound streams.
i_tsn	Transmission Sequence Number that the sender will use.
params	Optional/Variable-Length Parameters. a list of derived classes of <code>ryu.lib.packet.sctp.param</code> .

class `ryu.lib.packet.sctp.chunk_sack` (*flags=0, length=0, tsn_ack=0, a_rwnd=0, gapack_num=0, duptsn_num=0, gapacks=None, duptsns=None*)

Stream Control Transmission Protocol (SCTP) sub encoder/decoder class for Selective Acknowledgement (SACK) chunk (RFC 4960).

This is used with `ryu.lib.packet.sctp.sctp`.

An instance has the following attributes at least. Most of them are same to the on-wire counterparts but in host byte order. `__init__` takes the corresponding args in this order.

Attribute	Description
flags	set to '0'. this field will be ignored.
length	length of this chunk containing this header. (0 means automatically-calculate when encoding)
tsn_ack	TSN of the last DATA chunk received in sequence before a gap.
a_rwnd	Advertised Receiver Window Credit.
gapack_num	number of Gap Ack blocks.
duptsn_num	number of duplicate TSNS.
gapacks	a list of Gap Ack blocks. one block is made of a list with the start offset and the end offset from <code>tsn_ack</code> . e.g.) <code>gapacks = [[2, 3], [10, 12], [19, 21]]</code>
duptsns	a list of duplicate TSN.

class `ryu.lib.packet.sctp.chunk_shutdown` (*flags=0, length=0, tsn_ack=0*)

Stream Control Transmission Protocol (SCTP) sub encoder/decoder class for Shutdown Association (SHUTDOWN) chunk (RFC 4960).

This is used with `ryu.lib.packet.sctp.sctp`.

An instance has the following attributes at least. Most of them are same to the on-wire counterparts but in host byte order. `__init__` takes the corresponding args in this order.

Attribute	Description
flags	set to '0'. this field will be ignored.
length	length of this chunk containing this header. (0 means automatically-calculate when encoding)
tsn_ack	TSN of the last DATA chunk received in sequence before a gap.

class `ryu.lib.packet.sctp.chunk_shutdown_ack` (*flags=0, length=0*)

Stream Control Transmission Protocol (SCTP) sub encoder/decoder class for Shutdown Acknowledgement (SHUTDOWN ACK) chunk (RFC 4960).

This is used with `ryu.lib.packet.sctp.sctp`.

An instance has the following attributes at least. Most of them are same to the on-wire counterparts but in host byte order. `__init__` takes the corresponding args in this order.

Attribute	Description
flags	set to '0'. this field will be ignored.
length	length of this chunk containing this header. (0 means automatically-calculate when encoding)

class `ryu.lib.packet.sctp.chunk_shutdown_complete` (*tflag=0, length=0*)

Stream Control Transmission Protocol (SCTP) sub encoder/decoder class for Shutdown Complete (SHUTDOWN COMPLETE) chunk (RFC 4960).

This is used with `ryu.lib.packet.sctp.sctp`.

An instance has the following attributes at least. Most of them are same to the on-wire counterparts but in host byte order. `__init__` takes the corresponding args in this order.

Attribute	Description
tflag	'0' means the Verification tag is normal. '1' means the Verification tag is copy of the sender.
length	length of this chunk containing this header. (0 means automatically-calculate when encoding)

class `ryu.lib.packet.sctp.param_cookie_preserve` (*value=0, length=0*)

Stream Control Transmission Protocol (SCTP) sub encoder/decoder class for Cookie Preservative Parameter (RFC 4960).

This is used with `ryu.lib.packet.sctp.chunk_init`.

An instance has the following attributes at least. Most of them are same to the on-wire counterparts but in host byte order. `__init__` takes the corresponding args in this order.

Attribute	Description
value	Suggested Cookie Life-Span Increment (msec).
length	length of this param containing this header. (0 means automatically-calculate when encoding)

class `ryu.lib.packet.sctp.param_ecn` (*value=None, length=0*)

Stream Control Transmission Protocol (SCTP) sub encoder/decoder class for ECN Parameter (RFC 4960 Appendix A.).

This is used with `ryu.lib.packet.sctp.chunk_init` and `ryu.lib.packet.sctp.chunk_init_ack`.

An instance has the following attributes at least. Most of them are same to the on-wire counterparts but in host byte order. `__init__` takes the corresponding args in this order.

Attribute	Description
value	set to None.
length	length of this param containing this header. (0 means automatically-calculate when encoding)

class `ryu.lib.packet.sctp.param_heartbeat` (*value=None, length=0*)

Stream Control Transmission Protocol (SCTP) sub encoder/decoder class for Heartbeat Info Parameter (RFC 4960).

This is used with `ryu.lib.packet.sctp.chunk_heartbeat` and `ryu.lib.packet.sctp.chunk_heartbeat_ack`.

An instance has the following attributes at least. Most of them are same to the on-wire counterparts but in host byte order. `__init__` takes the corresponding args in this order.

Attribute	Description
value	the sender-specific heartbeat information.
length	length of this param containing this header. (0 means automatically-calculate when encoding)

class `ryu.lib.packet.sctp.param_host_addr` (*value=None, length=0*)

Stream Control Transmission Protocol (SCTP) sub encoder/decoder class for Host Name Address Parameter (RFC 4960).

This is used with `ryu.lib.packet.sctp.chunk_init` and `ryu.lib.packet.sctp.chunk_init_ack`.

An instance has the following attributes at least. Most of them are same to the on-wire counterparts but in host byte order. `__init__` takes the corresponding args in this order.

Attribute	Description
value	a host name that ends with null terminator.
length	length of this param containing this header. (0 means automatically-calculate when encoding)

class `ryu.lib.packet.sctp.param_ipv4` (*value='127.0.0.1', length=0*)

Stream Control Transmission Protocol (SCTP) sub encoder/decoder class for IPv4 Address Parameter (RFC 4960).

This is used with `ryu.lib.packet.sctp.chunk_init` and `ryu.lib.packet.sctp.chunk_init_ack`.

An instance has the following attributes at least. Most of them are same to the on-wire counterparts but in host byte order. `__init__` takes the corresponding args in this order.

Attribute	Description
value	IPv4 address of the sending endpoint.
length	length of this param containing this header. (0 means automatically-calculate when encoding)

class `ryu.lib.packet.sctp.param_ipv6` (*value='::1', length=0*)

Stream Control Transmission Protocol (SCTP) sub encoder/decoder class for IPv6 Address Parameter (RFC 4960).

This is used with `ryu.lib.packet.sctp.chunk_init` and `ryu.lib.packet.sctp.chunk_init_ack`.

An instance has the following attributes at least. Most of them are same to the on-wire counterparts but in host byte order. `__init__` takes the corresponding args in this order.

Attribute	Description
value	IPv6 address of the sending endpoint.
length	length of this param containing this header. (0 means automatically-calculate when encoding)

class `ryu.lib.packet.sctp.param_state_cookie` (*value=None, length=0*)

Stream Control Transmission Protocol (SCTP) sub encoder/decoder class for State Cookie Parameter (RFC 4960).

This is used with `ryu.lib.packet.sctp.chunk_init_ack`.

An instance has the following attributes at least. Most of them are same to the on-wire counterparts but in host byte order. `__init__` takes the corresponding args in this order.

Attribute	Description
value	the state cookie. see Section 5.1.3 in RFC 4960.
length	length of this param containing this header. (0 means automatically-calculate when encoding)

class `ryu.lib.packet.sctp.param_supported_addr` (*value=None, length=0*)
 Stream Control Transmission Protocol (SCTP) sub encoder/decoder class for Supported Address Types Parameter (RFC 4960).

This is used with `ryu.lib.packet.sctp.chunk_init`.

An instance has the following attributes at least. Most of them are same to the on-wire counterparts but in host byte order. `__init__` takes the corresponding args in this order.

Attribute	Description
<code>value</code>	a list of parameter types. odd cases pad with 0x0000.
<code>length</code>	length of this param containing this header. (0 means automatically-calculate when encoding)

class `ryu.lib.packet.sctp.param_unrecognized_param` (*value=None, length=0*)
 Stream Control Transmission Protocol (SCTP) sub encoder/decoder class for Unrecognized Parameter (RFC 4960).

This is used with `ryu.lib.packet.sctp.chunk_init_ack`.

An instance has the following attributes at least. Most of them are same to the on-wire counterparts but in host byte order. `__init__` takes the corresponding args in this order.

Attribute	Description
<code>value</code>	the unrecognized parameter in the INIT chunk.
<code>length</code>	length of this param containing this header. (0 means automatically-calculate when encoding)

class `ryu.lib.packet.sctp.sctp` (*src_port=1, dst_port=1, vtag=0, csum=0, chunks=None*)
 Stream Control Transmission Protocol (SCTP) header encoder/decoder class (RFC 4960).

An instance has the following attributes at least. Most of them are same to the on-wire counterparts but in host byte order. `__init__` takes the corresponding args in this order.

Attribute	Description
<code>src_port</code>	Source Port
<code>dst_port</code>	Destination Port
<code>vtag</code>	Verification Tag
<code>csum</code>	Checksum (0 means automatically-calculate when encoding)
<code>chunks</code>	a list of derived classes of <code>ryu.lib.packet.sctp.chunk</code> .

class `ryu.lib.packet.bfd.bfd` (*ver=1, diag=0, state=0, flags=0, detect_mult=0, my_discr=0, your_discr=0, desired_min_tx_interval=0, required_min_rx_interval=0, required_min_echo_rx_interval=0, auth_cls=None, length=None*)
 BFD (RFC 5880) Control packet encoder/decoder class.

The serialized packet would looks like the ones described in the following sections.

- RFC 5880 Generic BFD Control Packet Format

An instance has the following attributes at least. Most of them are same to the on-wire counterparts but in host byte order.

`__init__` takes the corresponding args in this order.

Attribute	Description
ver	The version number of the protocol. This class implements protocol version 1.
diag	A diagnostic code specifying the local system's reason for the last change in session state.
state	The current BFD session state as seen by the transmitting system.
flags	Bitmap of the following flags. BFD_FLAG_POLL BFD_FLAG_FINAL BFD_FLAG_CTRL_PLANE_INDEP BFD_FLAG_AUTH_PRESENT BFD_FLAG_DEMAND BFD_FLAG_MULTIPPOINT
detect_mult	Detection time multiplier.
my_discr	My Discriminator.
your_discr	Your Discriminator.
desired_min_tx_interval	Desired Min TX Interval. (in microseconds)
required_min_rx_interval	Required Min RX Interval. (in microseconds)
required_min_echo_rx_interval	Required Min Echo RX Interval. (in microseconds)
auth_cls	(Optional) Authentication Section instance. It's defined only when the Authentication Present (A) bit is set in flags. Assign an instance of the following classes: SimplePassword, KeyedMD5, MeticulousKeyedMD5, KeyedSHA1, and MeticulousKeyedSHA1.
length	(Optional) Length of the BFD Control packet, in bytes.

authenticate (*args, **kwargs)

Authenticate this packet.

Returns a boolean indicates whether the packet can be authenticated or not.

Returns `False` if the Authentication Present (A) is not set in the flag of this packet.

Returns `False` if the Authentication Section for this packet is not present.

For the description of the arguemnts of this method, refer to the authentication method of the Authentication Section classes.

pack ()

Encode a BFD Control packet without authentication section.

class ryu.lib.packet.bfd.**SimplePassword** (auth_key_id, password, auth_len=None)

BFD (RFC 5880) Simple Password Authentication Section class

An instance has the following attributes. Most of them are same to the on-wire counterparts but in host byte order.

Attribute	Description
auth_type	(Fixed) The authentication type in use.
auth_key_id	The authentication Key ID in use.
password	The simple password in use on this session. The password is a binary string, and MUST be from 1 to 16 bytes in length.
auth_len	The length, in bytes, of the authentication section, including the auth_type and auth_len fields.

authenticate (*prev=None, auth_keys=None*)

Authenticate the password for this packet.

This method can be invoked only when `self.password` is defined.

Returns a boolean indicates whether the password can be authenticated or not.

`prev` is a `bfd` instance for the BFD Control header. It's not necessary for authenticating the Simple Password.

`auth_keys` is a dictionary of authentication key chain which key is an integer of *Auth Key ID* and value is a string of *Password*.

serialize (*payload, prev*)

Encode a Simple Password Authentication Section.

`payload` is the rest of the packet which will immediately follow this section.

`prev` is a `bfd` instance for the BFD Control header. It's not necessary for encoding only the Simple Password section.

class `ryu.lib.packet.bfd.KeyedMD5` (*auth_key_id, seq, auth_key=None, digest=None, auth_len=None*)

BFD (RFC 5880) Keyed MD5 Authentication Section class

An instance has the following attributes. Most of them are same to the on-wire counterparts but in host byte order.

Attribute	Description
<code>auth_type</code>	(Fixed) The authentication type in use.
<code>auth_key_id</code>	The authentication Key ID in use.
<code>seq</code>	The sequence number for this packet. This value is incremented occasionally.
<code>auth_key</code>	The shared MD5 key for this packet.
<code>digest</code>	(Optional) The 16-byte MD5 digest for the packet.
<code>auth_len</code>	(Fixed) The length of the authentication section is 24 bytes.

authenticate (*prev, auth_keys=None*)

Authenticate the MD5 digest for this packet.

This method can be invoked only when `self.digest` is defined.

Returns a boolean indicates whether the digest can be authenticated by the correspondent Auth Key or not.

`prev` is a `bfd` instance for the BFD Control header which this authentication section belongs to. It's necessary to be assigned because an MD5 digest must be calculated over the entire BFD Control packet.

`auth_keys` is a dictionary of authentication key chain which key is an integer of *Auth Key ID* and value is a string of *Auth Key*.

serialize (*payload, prev*)

Encode a Keyed MD5 Authentication Section.

This method is used only when encoding an BFD Control packet.

`payload` is the rest of the packet which will immediately follow this section.

`prev` is a `bfd` instance for the BFD Control header which this authentication section belongs to. It's necessary to be assigned because an MD5 digest must be calculated over the entire BFD Control packet.

class `ryu.lib.packet.bfd.MeticulousKeyedMD5` (*auth_key_id, seq, auth_key=None, digest=None, auth_len=None*)

BFD (RFC 5880) Meticulous Keyed MD5 Authentication Section class

All methods of this class are inherited from `KeyedMD5`.

An instance has the following attributes. Most of them are same to the on-wire counterparts but in host byte order.

Attribute	Description
auth_type	(Fixed) The authentication type in use.
auth_key_id	The authentication Key ID in use.
seq	The sequence number for this packet. This value is incremented for each successive packet transmitted for a session.
auth_key	The shared MD5 key for this packet.
digest	(Optional) The 16-byte MD5 digest for the packet.
auth_len	(Fixed) The length of the authentication section is 24 bytes.

class `ryu.lib.packet.bfd.KeyedSHA1` (*auth_key_id*, *seq*, *auth_key=None*, *auth_hash=None*, *auth_len=None*)

BFD (RFC 5880) Keyed SHA1 Authentication Section class

An instance has the following attributes. Most of them are same to the on-wire counterparts but in host byte order.

Attribute	Description
auth_type	(Fixed) The authentication type in use.
auth_key_id	The authentication Key ID in use.
seq	The sequence number for this packet. This value is incremented occasionally.
auth_key	The shared SHA1 key for this packet.
auth_hash	(Optional) The 20-byte SHA1 hash for the packet.
auth_len	(Fixed) The length of the authentication section is 28 bytes.

authenticate (*prev*, *auth_keys=None*)

Authenticate the SHA1 hash for this packet.

This method can be invoked only when `self.auth_hash` is defined.

Returns a boolean indicates whether the hash can be authenticated by the correspondent Auth Key or not.

prev is a `bfd` instance for the BFD Control header which this authentication section belongs to. It's necessary to be assigned because an SHA1 hash must be calculated over the entire BFD Control packet.

auth_keys is a dictionary of authentication key chain which key is an integer of *Auth Key ID* and value is a string of *Auth Key*.

serialize (*payload*, *prev*)

Encode a Keyed SHA1 Authentication Section.

This method is used only when encoding an BFD Control packet.

payload is the rest of the packet which will immediately follow this section.

prev is a `bfd` instance for the BFD Control header which this authentication section belongs to. It's necessary to be assigned because an SHA1 hash must be calculated over the entire BFD Control packet.

class `ryu.lib.packet.bfd.MeticulousKeyedSHA1` (*auth_key_id*, *seq*, *auth_key=None*, *auth_hash=None*, *auth_len=None*)

BFD (RFC 5880) Meticulous Keyed SHA1 Authentication Section class

All methods of this class are inherited from `KeyedSHA1`.

An instance has the following attributes. Most of them are same to the on-wire counterparts but in host byte order.

Attribute	Description
auth_type	(Fixed) The authentication type in use.
auth_key_id	The authentication Key ID in use.
seq	The sequence number for this packet. This value is incremented for each successive packet transmitted for a session.
auth_key	The shared SHA1 key for this packet.
auth_hash	(Optional) The 20-byte SHA1 hash for the packet.
auth_len	(Fixed) The length of the authentication section is 28 bytes.

2.4.3 OF-Config support

Ryu has a library for OF-Config support.

XML schema files for NETCONFIG and OFConfig

XML schema files for NETCONF and OFConfig are stolen from LINC whose licence is Apache 2.0. It supports only part of OFConfig so that its schema files are (intentionally) limited such that operation attributes are allowed only in several limited places. Once our library is tested with other OFConfig switches, the schema files should be updated to allow operation attribute in more places.

References

- [NETCONF ietf](#),
- [NETCONF ietf wiki](#),
- [OF-Config spec](#),
- [ncclient](#),
- [ncclient repo](#),
- [LINC git repo](#)

2.4.4 BGP speaker library

Introduction

Ryu BGP speaker library helps you to enable your code to speak BGP protocol. The library supports ipv4, ipv4 vpn, and ipv6 vpn address families.

Example

The following simple code creates a BGP instance with AS number 64512 and Router ID 10.0.0.1. It tries to establish a bgp session with a peer (its IP is 192.168.177.32 and the AS number is 64513). The instance advertizes some prefixes.

```
import eventlet

# BGPSpeaker needs sockets patched
eventlet.monkey_patch()

# initialize a log handler
# this is not strictly necessary but useful if you get messages like:
```

```

# No handlers could be found for logger "ryu.lib.hub"
import logging
import sys
log = logging.getLogger()
log.addHandler(logging.StreamHandler(sys.stderr))

from ryu.services.protocols.bgp.bgpspeaker import BGPSpeaker

def dump_remote_best_path_change(event):
    print 'the best path changed:', event.remote_as, event.prefix, \
          event.nextthop, event.is_withdraw

def detect_peer_down(remote_ip, remote_as):
    print 'Peer down:', remote_ip, remote_as

if __name__ == "__main__":
    speaker = BGPSpeaker(as_number=64512, router_id='10.0.0.1',
                        best_path_change_handler=dump_remote_best_path_change,
                        peer_down_handler=detect_peer_down)

    speaker.neighbor_add('192.168.177.32', 64513)
    # uncomment the below line if the speaker needs to talk with a bmp server.
    # speaker.bmp_server_add('192.168.177.2', 11019)
    count = 1
    while True:
        eventlet.sleep(30)
        prefix = '10.20.' + str(count) + '.0/24'
        print "add a new prefix", prefix
        speaker.prefix_add(prefix)
        count += 1
        if count == 4:
            speaker.shutdown()
            break

```

2.4.5 BGP speaker library API Reference

BGPSpeaker class

```

class ryu.services.protocols.bgp.bgpspeaker.BGPSpeaker (as_number, router_id,
                                                         bgp_server_port=179, re-
                                                         fresh_stalepath_time=0,
                                                         refresh_max_eor_time=0,
                                                         best_path_change_handler=None,
                                                         peer_down_handler=None,
                                                         peer_up_handler=None,
                                                         ssh_console=False, la-
                                                         bel_range=(100, 100000))

```

attribute_map_get (address, route_dist=None, route_family='ipv4')

This method gets in-bound filters of the specified neighbor.

address specifies the IP address of the neighbor.

route_dist specifies route distinguisher that has attribute_maps.

route_family specifies route family of the VRF. This parameter must be RF_VPN_V4 or RF_VPN_V6.

Returns a list object containing an instance of AttributeMap

attribute_map_set (*address, attribute_maps, route_dist=None, route_family='ipv4'*)

This method sets attribute mapping to a neighbor. attribute mapping can be used when you want to apply attribute to BGPUpdate under specific conditions.

address specifies the IP address of the neighbor

attribute_maps specifies attribute_map list that are used before paths are advertised. All the items in the list must be an instance of AttributeMap class

route_dist specifies route dist in which attribute_maps are added.

route_family specifies route family of the VRF. This parameter must be RF_VPN_V4 or RF_VPN_V6.

We can set AttributeMap to a neighbor as follows;

```
pref_filter = PrefixFilter('192.168.103.0/30', PrefixFilter.POLICY_PERMIT)
```

```
attribute_map = AttributeMap([pref_filter], AttributeMap.ATTR_LOCAL_PREF, 250)
```

```
speaker.attribute_map_set('192.168.50.102', [attribute_map])
```

bmp_server_add (*address, port*)

This method registers a new BMP (BGP monitoring Protocol) server. The BGP speaker starts to send BMP messages to the server. Currently, only one BMP server can be registered.

address specifies the IP address of a BMP server.

port specifies the listen port number of a BMP server.

bmp_server_del (*address, port*)

This method unregister the registered BMP server.

address specifies the IP address of a BMP server.

port specifies the listen port number of a BMP server.

in_filter_get (*address*)

This method gets in-bound filters of the specified neighbor.

address specifies the IP address of the neighbor.

Returns a list object containing an instance of Filter sub-class

in_filter_set (*address, filters*)

This method sets in-bound filters to a neighbor.

address specifies the IP address of the neighbor

filters specifies filter list applied before advertised paths are imported to the global rib. All the items in the list must be an instance of Filter sub-class.

neighbor_add (*address, remote_as, enable_ipv4=True, enable_vpnv4=False, enable_vpnv6=False, enable_enhanced_refresh=False, next_hop=None, password=None, multi_exit_disc=None, site_of_origins=None, is_route_server_client=False, is_next_hop_self=False, local_address=None, local_port=None, connect_mode='both'*)

This method registers a new neighbor. The BGP speaker tries to establish a bgp session with the peer (accepts a connection from the peer and also tries to connect to it).

address specifies the IP address of the peer. It must be the string representation of an IP address. Only IP v4 is supported now.

remote_as specifies the AS number of the peer. It must be an integer between 1 and 65535.

`enable_ipv4` enables IPv4 address family for this neighbor. The default is True.

`enable_vpnv4` enables VPNv4 address family for this neighbor. The default is False.

`enable_vpnv6` enables VPNv6 address family for this neighbor. The default is False.

`next_hop` specifies the next hop IP address. If not specified, host's ip address to access to a peer is used.

`password` is used for the MD5 authentication if it's specified. By default, the MD5 authentication is disabled.

`multi_exit_disc` specifies multi exit discriminator (MED) value. The default is None and if not specified, MED value is not sent to the neighbor. It must be an integer.

`site_of_origins` specifies site_of_origin values. This parameter must be a list of string.

`is_route_server_client` specifies whether this neighbor is a router server's client or not.

`is_next_hop_self` specifies whether the BGP speaker announces its own ip address to iBGP neighbor or not as path's next_hop address.

`connect_mode` specifies how to connect to this neighbor. `CONNECT_MODE_ACTIVE` tries to connect from us. `CONNECT_MODE_PASSIVE` just listens and wait for the connection. `CONNECT_MODE_BOTH` use both methods. The default is `CONNECT_MODE_BOTH`

`local_address` specifies Loopback interface address for iBGP peering.

`local_port` specifies source TCP port for iBGP peering.

neighbor_del (*address*)

This method unregister the registered neighbor. If a session with the peer exists, the session will be closed.

`address` specifies the IP address of the peer. It must be the string representation of an IP address.

neighbor_get (*roustetype, address, format='json'*)

This method returns the BGP adj-RIB-in information in a json format.

`roustetype` This parameter is necessary for only received-routes and sent-routes.

received-routes : paths received and not withdrawn by given peer

sent-routes : paths sent and not withdrawn to given peer

`address` specifies the IP address of the peer. It must be the string representation of an IP address.

neighbor_reset (*address*)

This method reset the registered neighbor.

`address` specifies the IP address of the peer. It must be the string representation of an IP address.

neighbor_state_get (*address=None, format='json'*)

This method returns the state of peer(s) in a json format.

`address` specifies the address of a peer. If not given, the state of all the peers return.

neighbor_update (*address, conf_type, conf_value*)

This method changes the neighbor configuration.

`conf_type` specifies configuration type which you want to change. Currently `ryu.services.protocols.bgp.bgpspeaker.NEIGHBOR_CONF_MED` can be specified.

`conf_value` specifies value for the configuration type.

out_filter_get (*address*)

This method gets out-filter setting from the specified neighbor.

`address` specifies the IP address of the peer.

Returns a list object containing an instance of Filter sub-class

out_filter_set (*address, filters*)

This method sets out-filter to neighbor.

address specifies the IP address of the peer.

filters specifies a filter list to filter the path advertisement. The contents must be an instance of Filter sub-class

If you want to define out-filter that send only a particular prefix to neighbor, filters can be created as follows;

```
p = PrefixFilter('10.5.111.0/24', policy=PrefixFilter.POLICY_PERMIT)
```

```
all = PrefixFilter('0.0.0.0/0', policy=PrefixFilter.POLICY_DENY)
```

```
pList = [p, all]
```

```
self.bgpspeaker.out_filter_set(neighbor_address, pList)
```

NOTE: out-filter evaluates paths in the order of Filter in the pList.

prefix_add (*prefix, next_hop=None, route_dist=None*)

This method adds a new prefix to be advertized.

prefix must be the string representation of an IP network (e.g., 10.1.1.0/24).

next_hop specifies the next hop address for this prefix. This parameter is necessary for only VPNv4 and VPNv6 address families.

route_dist specifies a route distinguisher value. This parameter is necessary for only VPNv4 and VPNv6 address families.

prefix_del (*prefix, route_dist=None*)

This method deletes a advertized prefix.

prefix must be the string representation of an IP network (e.g., 10.1.1.0/24).

route_dist specifies a route distinguisher value. This parameter is necessary for only VPNv4 and VPNv6 address families.

rib_get (*family='ipv4', format='json'*)

This method returns the BGP routing information in a json format. This will be improved soon.

family specifies the address family of the RIB.

shutdown ()

Shutdown BGP speaker

vrf_add (*route_dist, import_rts, export_rts, site_of_origins=None, route_family='ipv4', multi_exit_disc=None*)

This method adds a new vrf used for VPN.

route_dist specifies a route distinguisher value.

import_rts specifies route targets to be imported.

export_rts specifies route targets to be exported.

site_of_origins specifies *site_of_origin* values. This parameter must be a list of string.

route_family specifies route family of the VRF. This parameter must be RF_VPN_V4 or RF_VPN_V6.

vrf_del (*route_dist*)

This method deletes the existing vrf.

route_dist specifies a route distinguisher value.

class `ryu.services.protocols.bgp.bgpspeaker.EventPrefix` (*remote_as, route_dist, prefix, nexthop, label, is_withdraw*)

Used to pass an update on any best remote path to `best_path_change_handler`.

Attribute	Description
<code>remote_as</code>	The AS number of a peer that caused this change
<code>route_dist</code>	None in the case of ipv4 or ipv6 family
<code>prefix</code>	A prefix was changed
<code>nexthop</code>	The nexthop of the changed prefix
<code>label</code>	mpls label for vpnv4 prefix
<code>is_withdraw</code>	True if this prefix has gone otherwise False

class `ryu.services.protocols.bgp.info_base.base.PrefixFilter` (*prefix, policy, ge=None, le=None*)

used to specify a prefix for filter.

We can create PrefixFilter object as follows.

prefix_filter = PrefixFilter('10.5.111.0/24', policy=PrefixFilter.POLICY_PERMIT)

Attribute	Description
<code>prefix</code>	A prefix used for this filter
<code>policy</code>	PrefixFilter.POLICY.PERMIT or PrefixFilter.POLICY_DENY
<code>ge</code>	Prefix length that will be applied to this filter. ge means greater than or equal.
<code>le</code>	Prefix length that will be applied to this filter. le means less than or equal.

For example, when PrefixFilter object is created as follows:

•p = PrefixFilter('10.5.111.0/24', policy=PrefixFilter.POLICY_DENY, ge=26, le=28)

prefixes which match 10.5.111.0/24 and its length matches from 26 to 28 will be filtered. When this filter is used as an out-filter, it will stop sending the path to neighbor because of POLICY_DENY. When this filter is used as in-filter, it will stop importing the path to the global rib because of POLICY_DENY. If you specify POLICY_PERMIT, the path is sent to neighbor or imported to the global rib.

If you don't want to send prefixes 10.5.111.64/26 and 10.5.111.32/27 and 10.5.111.16/28, and allow to send other 10.5.111.0's prefixes, you can do it by specifying as follows;

•p = PrefixFilter('10.5.111.0/24', policy=PrefixFilter.POLICY_DENY, ge=26, le=28).

clone ()

This method clones PrefixFilter object.

Returns PrefixFilter object that has the same values with the original one.

evaluate (*path*)

This method evaluates the prefix.

Returns this object's policy and the result of matching. If the specified prefix matches this object's prefix and ge and le condition, this method returns True as the matching result.

path specifies the path that has prefix.

class `ryu.services.protocols.bgp.info_base.base.ASPathFilter` (*as_number, policy*)

used to specify a prefix for AS_PATH attribute.

We can create ASPathFilter object as follows;

•as_path_filter = ASPathFilter(65000,policy=ASPathFilter.TOP)

Attribute	Description
as_number	A AS number used for this filter
policy	ASPathFilter.POLICY_TOP and ASPathFilter.POLICY_END, ASPathFilter.POLICY_INCLUDE and ASPathFilter.POLICY_NOT_INCLUDE are available.

Meaning of each policy is as follows;

- **POLICY_TOP** : Filter checks if the specified AS number is at the top of AS_PATH attribute.
- **POLICY_END** : Filter checks is the specified AS number is at the last of AS_PATH attribute.
- **POLICY_INCLUDE** : Filter checks if specified AS number exists in AS_PATH attribute
- **POLICY_NOT_INCLUDE** : opposite to POLICY_INCLUDE

clone ()

This method clones ASPathFilter object.

Returns ASPathFilter object that has the same values with the original one.

evaluate (path)

This method evaluates as_path list.

Returns this object's policy and the result of matching. If the specified AS number matches this object's AS number according to the policy, this method returns True as the matching result.

path specifies the path.

class ryu.services.protocols.bgp.info_base.base.**AttributeMap** (*filters*, *attr_type*, *attr_value*)

This class is used to specify an attribute to add if the path matches filters. We can create AttributeMap object as follows;

```
pref_filter = PrefixFilter('192.168.103.0/30', PrefixFilter.POLICY_PERMIT)
```

```
attribute_map = AttributeMap([pref_filter], AttributeMap.ATTR_LOCAL_PREF, 250)
```

```
speaker.attribute_map_set('192.168.50.102', [attribute_map])
```

AttributeMap.ATTR_LOCAL_PREF means that 250 is set as a local preference value if nlri in the path matches pref_filter.

ASPathFilter is also available as a filter. ASPathFilter checks if AS_PATH attribute in the path matches AS number in the filter.

Attribute	Description
filters	A list of filter. Each object should be a Filter class or its sub-class
attr_type	A type of attribute to map on filters. Currently AttributeMap.ATTR_LOCAL_PREF is available.
attr_value	A attribute value

clone ()

This method clones AttributeMap object.

Returns AttributeMap object that has the same values with the original one.

evaluate (path)

This method evaluates attributes of the path.

Returns the cause and result of matching. Both cause and result are returned from filters that this object contains.

path specifies the path.

2.4.6 OVSDB Manager library

Introduction

Ryu OVSDB Manager library allows your code to interact with devices speaking the OVSDB protocol. This enables your code to perform remote management of the devices and react to topology changes on them.

Example

The following logs all new OVSDB connections and allows creating a port on a bridge.

```
import uuid

from ryu.base import app_manager
from ryu.services.protocols.ovsdb import api as ovsdb
from ryu.services.protocols.ovsdb import event as ovsdb_event

class MyApp(app_manager.RyuApp):
    @set_ev_cls(ovsdb_event.EventNewOVSDBConnection)
    def handle_new_ovsdb_connection(self, ev):
        system_id = ev.system_id
        self.logger.info('New OVSDB connection from system id %s',
                        system_id)

    def create_port(self, system_id, bridge_name, name):
        new_iface_uuid = uuid.uuid4()
        new_port_uuid = uuid.uuid4()

    def _create_port(self, tables, insert):
        bridge = ovsdb.row_by_name(self, system_id, bridge_name)

        iface = insert(tables['Interface'], new_iface_uuid)
        iface.name = name
        iface.type = 'internal'

        port = insert(tables['Port'], new_port_uuid)
        port.name = name
        port.interfaces = [iface]

        bridge.ports = bridge.ports + [port]

        return (new_port_uuid, new_iface_uuid)

    req = ovsdb_event.EventModifyRequest(system_id, _create_port)
    rep = self.send_request(req)

    if rep.status != 'success':
        self.logger.error('Error creating port %s on bridge %s: %s',
                        name, bridge, rep.status)
        return None

    return reply.insert_uuid[new_port_uuid]
```

2.5 OpenFlow protocol API Reference

2.5.1 OpenFlow version independent classes and functions

Base class for OpenFlow messages

class `ryu.ofproto.ofproto_parser.MsgBase` (**args, **kwargs*)

This is a base class for OpenFlow message classes.

An instance of this class has at least the following attributes.

Attribute	Description
<code>datapath</code>	A <code>ryu.controller.controller.Datapath</code> instance for this message
<code>version</code>	OpenFlow protocol version
<code>msg_type</code>	Type of OpenFlow message
<code>msg_len</code>	Length of the message
<code>xid</code>	Transaction id
<code>buf</code>	Raw data

`_TYPE`

`_TYPE` class attribute is used to annotate types of attributes.

This type information is used to find an appropriate conversion for a JSON style dictionary.

Currently the following types are implemented.

Type	Description
<code>ascii</code>	US-ASCII
<code>utf-8</code>	UTF-8

Example:

```
_TYPE = {
    'ascii': [
        'hw_addr',
    ],
    'utf-8': [
        'name',
    ]
}
```

from_jsondict (*dict_, decode_string=<function b64decode>, **additional_args*)

Create an instance from a JSON style dict.

Instantiate this class with parameters specified by the dict.

This method takes the following arguments.

Argument	Description
<code>dict_</code>	A dictionary which describes the parameters. For example, {"Param1": 100, "Param2": 200}
<code>decode_string</code>	(Optional) specify how to decode strings. The default is base64. This argument is used only for attributes which don't have explicit type annotations in <code>_TYPE</code> class attribute.
<code>additional_args</code>	(Optional) Additional kwargs for constructor.

to_jsondict (*encode_string=<function b64encode>*)

This method returns a JSON style dict to describe this object.

The returned dict is compatible with `json.dumps()` and `json.loads()`.

Suppose `ClassName` object inherits `StringifyMixin`. For an object like the following:

```
ClassName (Param1=100, Param2=200)
```

this method would produce:

```
{ "ClassName": {"Param1": 100, "Param2": 200} }
```

This method takes the following arguments.

Argument	Description
<code>encode_string</code>	(Optional) specify how to encode attributes which has python 'str' type. The default is base64. This argument is used only for attributes which don't have explicit type annotations in <code>_TYPE</code> class attribute.

Functions

`ryu.ofproto.ofproto_parser.ofp_msg_from_jsondict` (*dp*, *jsondict*)

This function instantiates an appropriate OpenFlow message class from the given JSON style dictionary. The objects created by following two code fragments are equivalent.

Code A:

```
jsonstr = '{ "OFPSetConfig": { "flags": 0, "miss_send_len": 128 } }'
jsondict = json.loads(jsonstr)
o = ofp_msg_from_jsondict(dp, jsondict)
```

Code B:

```
o = dp.ofproto_parser.OFPSetConfig(flags=0, miss_send_len=128)
```

This function takes the following arguments.

Argument	Description
<code>dp</code>	An instance of <code>ryu.controller.Datapath</code> .
<code>jsondict</code>	A JSON style dict.

2.5.2 OpenFlow v1.0 Messages and Structures

Controller-to-Switch Messages

Handshake

class `ryu.ofproto.ofproto_v1_0_parser.OFPFeaturesRequest` (*datapath*)

Features request message

The controller sends a feature request to the switch upon session establishment.

This message is handled by the Ryu framework, so the Ryu application do not need to process this typically.

Example:

```
def send_features_request(self, datapath):
    ofp_parser = datapath.ofproto_parser

    req = ofp_parser.OFPFeaturesRequest(datapath)
    datapath.send_msg(req)
```

JSON Example:

```
{
  "OFPPFeaturesRequest": {}
}
```

```
class ryu.ofproto.ofproto_v1_0_parser.OFPSwitchFeatures (datapath, datapath_id=None,
                                                         n_buffers=None,
                                                         n_tables=None, capabilities=None,
                                                         actions=None,
                                                         ports=None)
```

Features reply message

The switch responds with a features reply message to a features request.

This message is handled by the Ryu framework, so the Ryu application do not need to process this typically.

Attribute	Description
datapath_id	Datapath unique ID.
n_buffers	Max packets buffered at once.
n_tables	Number of tables supported by datapath.
capabilities	Bitmap of capabilities flag. OFPC_FLOW_STATS OFPC_TABLE_STATS OFPC_PORT_STATS OFPC_STP OFPC_RESERVED OFPC_IP_REASM OFPC_QUEUE_STATS OFPC_ARP_MATCH_IP
actions	Bitmap of supported OFFPAT_*.
ports	List of OFPPhyPort instances.

Example:

```
@set_ev_cls(ofp_event.EventOFPSwitchFeatures, CONFIG_DISPATCHER)
def switch_features_handler(self, ev):
    msg = ev.msg

    self.logger.debug('OFPSwitchFeatures received: '
                      'datapath_id=0x%016x n_buffers=%d '
                      'n_tables=%d capabilities=0x%08x ports=%s',
                      msg.datapath_id, msg.n_buffers, msg.n_tables,
                      msg.capabilities, msg.ports)
```

JSON Example:

```
{
  "OFPSwitchFeatures": {
    "actions": 2115,
    "capabilities": 169,
    "datapath_id": 1095522080376,
    "n_buffers": 0,
    "n_tables": 255,
    "ports": {
      "6": {
```

```

        "OFPPhyPort": {
            "advertised": 640,
            "config": 0,
            "curr": 648,
            "hw_addr": "f2:0b:a4:7d:f8:ea",
            "name": "Port6",
            "peer": 648,
            "port_no": 6,
            "state": 2,
            "supported": 648
        }
    },
    "7": {
        "OFPPhyPort": {
            "advertised": 640,
            "config": 0,
            "curr": 648,
            "hw_addr": "f2:0b:a4:d0:3f:70",
            "name": "Port7",
            "peer": 648,
            "port_no": 7,
            "state": 16,
            "supported": 648
        }
    }
}
}
}
}
}

```

Switch Configuration

class ryu.ofproto.ofproto_v1_0_parser.**OFPSetsConfig**(datapath, *flags=None*, *miss_send_len=None*)

Set config request message

The controller sends a set config request message to set configuration parameters.

Attribute	Description
flags	One of the following configuration flags. OFPC_FRAG_NORMAL OFPC_FRAG_DROP OFPC_FRAG_REASM OFPC_FRAG_MASK
miss_send_len	Max bytes of new flow that datapath should send to the controller.

Example:

```

def send_set_config(self, datapath):
    ofp = datapath.ofproto
    ofp_parser = datapath.ofproto_parser

    req = ofp_parser.OFPSetsConfig(datapath, ofp.OFPC_FRAG_NORMAL, 256)
    datapath.send_msg(req)

```

class `ryu.ofproto.ofproto_v1_0_parser.OFPGetConfigRequest (datapath)`
 Get config request message

The controller sends a get config request to query configuration parameters in the switch.

Example:

```
def send_get_config_request(self, datapath):
    ofp_parser = datapath.ofproto_parser

    req = ofp_parser.OFPGetConfigRequest(datapath)
    datapath.send_msg(req)
```

class `ryu.ofproto.ofproto_v1_0_parser.OFPGetConfigReply (datapath)`
 Get config reply message

The switch responds to a configuration request with a get config reply message.

Attribute	Description
flags	One of the following configuration flags. OFPC_FRAG_NORMAL OFPC_FRAG_DROP OFPC_FRAG_REASM OFPC_FRAG_MASK
miss_send_len	Max bytes of new flow that datapath should send to the controller.

Example:

```
@set_ev_cls(ofp_event.EventOFPGetConfigReply, MAIN_DISPATCHER)
def get_config_reply_handler(self, ev):
    msg = ev.msg
    dp = msg.datapath
    ofp = dp.ofproto

    if msg.flags == ofp.OFPC_FRAG_NORMAL:
        flags = 'NORMAL'
    elif msg.flags == ofp.OFPC_FRAG_DROP:
        flags = 'DROP'
    elif msg.flags == ofp.OFPC_FRAG_REASM:
        flags = 'REASM'
    elif msg.flags == ofp.OFPC_FRAG_MASK:
        flags = 'MASK'
    else:
        flags = 'unknown'
    self.logger.debug('OFPGetConfigReply received: '
                      'flags=%s miss_send_len=%d',
                      flags, msg.miss_send_len)
```

Modify State Messages

```
class ryu.ofproto.ofproto_v1_0_parser.OFPFlowMod(datapath, match, cookie, command,
                                                  idle_timeout=0, hard_timeout=0, priority=32768,
                                                  buffer_id=4294967295, out_port=65535, flags=0,
                                                  actions=None)
```

Modify Flow entry message

The controller sends this message to modify the flow table.

Attribute	Description
match	Instance of OFPMatch.
cookie	Opaque controller-issued identifier.
command	One of the following values. OFPFC_ADD OFPFC_MODIFY OFPFC_MODIFY_STRICT OFPFC_DELETE OFPFC_DELETE_STRICT
idle_timeout	Idle time before discarding (seconds).
hard_timeout	Max time before discarding (seconds).
priority	Priority level of flow entry.
buffer_id	Buffered packet to apply to (or 0xffffffff). Not meaningful for OFPFC_DELETE*.
out_port	For OFPFC_DELETE* commands, require matching entries to include this as an output port. A value of OFPP_NONE indicates no restriction.
flags	One of the following values. OFPFF_SEND_FLOW_REM OFPFF_CHECK_OVERLAP OFPFF_EMERG
actions	List of OFPAction* instance.

Example:

```
def send_flow_mod(self, datapath):
    ofp = datapath.ofproto
    ofp_parser = datapath.ofproto_parser

    match = ofp_parser.OFPMatch(in_port=1)
    cookie = 0
    command = ofp.OFPFC_ADD
    idle_timeout = hard_timeout = 0
    priority = 32768
    buffer_id = 0xffffffff
    out_port = ofproto.OFPP_NONE
    flags = 0
    actions = [ofp_parser.OFPActionOutput(ofp.OFPP_NORMAL, 0)]
    req = ofp_parser.OFPFlowMod(
        datapath, match, cookie, command, idle_timeout, hard_timeout,
        priority, buffer_id, out_port, flags, actions)
```

```
datapath.send_msg(req)
```

JSON Example:

```
{
  "OFPPortMod": {
    "actions": [
      {
        "OFPPortMod": {
          "max_len": 65535,
          "port": 6
        }
      }
    ],
    "buffer_id": 65535,
    "command": 0,
    "cookie": 0,
    "flags": 0,
    "hard_timeout": 0,
    "idle_timeout": 0,
    "match": {
      "OFPMatch": {
        "dl_dst": "f2:0b:a4:7d:f8:ea",
        "dl_src": "00:00:00:00:00:00",
        "dl_type": 0,
        "dl_vlan": 0,
        "dl_vlan_pcp": 0,
        "in_port": 0,
        "nw_dst": "0.0.0.0",
        "nw_proto": 0,
        "nw_src": "0.0.0.0",
        "nw_tos": 0,
        "tp_dst": 0,
        "tp_src": 0,
        "wildcards": 4194295
      }
    },
    "out_port": 65532,
    "priority": 123
  }
}
```

```
class ryu.ofproto.ofproto_v1_0_parser.OFPPortMod(datapath, port_no=0,
                                                hw_addr='00:00:00:00:00:00', con-
                                                fig=0, mask=0, advertise=0)
```

Port modification message

The controller send this message to modify the behavior of the port.

Attribute	Description
port_no	Port number to modify.
hw_addr	The hardware address that must be the same as hw_addr of OFPPhyPort of OFPSwitchFeatures.
config	Bitmap of configuration flags. OFPPC_PORT_DOWN OFPPC_NO_STP OFPPC_NO_RECV OFPPC_NO_RECV_STP OFPPC_NO_FLOOD OFPPC_NO_FWD OFPPC_NO_PACKET_IN
mask	Bitmap of configuration flags above to be changed
advertise	Bitmap of the following flags. OFPPF_10MB_HD OFPPF_10MB_FD OFPPF_100MB_HD OFPPF_100MB_FD OFPPF_1GB_HD OFPPF_1GB_FD OFPPF_10GB_FD OFPPF_COPPER OFPPF_FIBER OFPPF_AUTONEG OFPPF_PAUSE OFPPF_PAUSE_ASYM

Example:

```
def send_port_mod(self, datapath):
    ofp = datapath.ofproto
    ofp_parser = datapath.ofproto_parser

    port_no = 3
    hw_addr = 'fa:c8:e8:76:1d:7e'
    config = 0
    mask = (ofp.OFPPC_PORT_DOWN | ofp.OFPPC_NO_RECV |
            ofp.OFPPC_NO_FWD | ofp.OFPPC_NO_PACKET_IN)
    advertise = (ofp.OFPPF_10MB_HD | ofp.OFPPF_100MB_FD |
                 ofp.OFPPF_1GB_FD | ofp.OFPPF_COPPER |
                 ofp.OFPPF_AUTONEG | ofp.OFPPF_PAUSE |
                 ofp.OFPPF_PAUSE_ASYM)
    req = ofp_parser.OFPPortMod(datapath, port_no, hw_addr, config,
                                mask, advertise)

    datapath.send_msg(req)
```

Queue Configuration Messages

class ryu.ofproto.ofproto_v1_0_parser.OFPQueueGetConfigRequest (datapath, port)
Queue configuration request message

Attribute	Description
port	Port to be queried. Should refer to a valid physical port (i.e. < OFPP_MAX).

Example:

```
def send_queue_get_config_request(self, datapath):
    ofp = datapath.ofproto
    ofp_parser = datapath.ofproto_parser

    req = ofp_parser.OFPQueueGetConfigRequest (datapath,
                                                ofp.OFPP_NONE)

    datapath.send_msg(req)
```

class ryu.ofproto.ofproto_v1_0_parser.OFPQueueGetConfigReply (datapath)
Queue configuration reply message

The switch responds with this message to a queue configuration request.

Attribute	Description
port	Port to be queried.
queues	List of OFPPacketQueue instance.

Example:

```
@set_ev_cls(ofp_event.EventOFPQueueGetConfigReply, MAIN_DISPATCHER)
def queue_get_config_reply_handler(self, ev):
    msg = ev.msg

    self.logger.debug('OFPQueueGetConfigReply received: '
                      'port=%s queues=%s',
                      msg.port, msg.queues)
```

Read State Messages

class ryu.ofproto.ofproto_v1_0_parser.OFPDescStatsRequest (datapath, flags)
Description statistics request message

The controller uses this message to query description of the switch.

Attribute	Description
flags	Zero (none yet defined in the spec).

Example:

```
def send_desc_stats_request(self, datapath):
    ofp_parser = datapath.ofproto_parser

    req = ofp_parser.OFPDescStatsRequest (datapath)

    datapath.send_msg(req)
```

class ryu.ofproto.ofproto_v1_0_parser.OFPDescStatsReply (datapath)
Description statistics reply message

The switch responds with a stats reply that include this message to a description statistics request.

Attribute	Description
mfr_desc	Manufacturer description.
hw_desc	Hardware description.
sw_desc	Software description.
serial_num	Serial number.
dp_desc	Human readable description of datapath.

Example:

```
@set_ev_cls(ofp_event.EventOFPPDescStatsReply, MAIN_DISPATCHER)
def desc_stats_reply_handler(self, ev):
    msg = ev.msg
    ofp = msg.datapath.ofproto
    body = ev.msg.body

    self.logger.debug('DescStats: mfr_desc=%s hw_desc=%s sw_desc=%s '
                      'serial_num=%s dp_desc=%s',
                      body.mfr_desc, body.hw_desc, body.sw_desc,
                      body.serial_num, body.dp_desc)
```

class ryu.ofproto.ofproto_v1_0_parser.OFPFlowStatsRequest (datapath, flags, match, table_id, out_port)

Individual flow statistics request message

The controller uses this message to query individual flow statistics.

Attribute	Description
flags	Zero (none yet defined in the spec).
match	Instance of OFPMatch.
table_id	ID of table to read (from ofp_table_stats), 0xff for all tables or 0xfe for emergency.
out_port	Require matching entries to include this as an output port. A value of OFPP_NONE indicates no restriction.

Example:

```
def send_flow_stats_request(self, datapath):
    ofp = datapath.ofproto
    ofp_parser = datapath.ofproto_parser

    match = ofp_parser.OFPMatch(in_port=1)
    table_id = 0xff
    out_port = ofp.OFPP_NONE
    req = ofp_parser.OFPFlowStatsRequest(
        datapath, 0, match, table_id, out_port)

    datapath.send_msg(req)
```

class ryu.ofproto.ofproto_v1_0_parser.OFPFlowStatsReply (datapath)

Individual flow statistics reply message

The switch responds with a stats reply that include this message to an individual flow statistics request.

Attribute	Description
table_id	ID of table flow came from.
match	Instance of OFPMatch.
duration_sec	Time flow has been alive in seconds.
duration_nsec	Time flow has been alive in nanoseconds beyond duration_sec.
priority	Priority of the entry. Only meaningful when this is not an exact-match entry.
idle_timeout	Number of seconds idle before expiration.
hard_timeout	Number of seconds before expiration.
cookie	Opaque controller-issued identifier.
packet_count	Number of packets in flow.
byte_count	Number of bytes in flow.
actions	List of OFPAction* instance

Example:

```
@set_ev_cls(ofp_event.EventOFPFlowStatsReply, MAIN_DISPATCHER)
def flow_stats_reply_handler(self, ev):
    msg = ev.msg
    ofp = msg.datapath.ofproto
    body = ev.msg.body

    flows = []
    for stat in body:
        flows.append('table_id=%s match=%s '
                    'duration_sec=%d duration_nsec=%d '
                    'priority=%d '
                    'idle_timeout=%d hard_timeout=%d '
                    'cookie=%d packet_count=%d byte_count=%d '
                    'actions=%s' %
                    (stat.table_id,
                     stat.duration_sec, stat.duration_nsec,
                     stat.priority,
                     stat.idle_timeout, stat.hard_timeout,
                     stat.cookie, stat.packet_count, stat.byte_count,
                     stat.match, stat.actions))
    self.logger.debug('FlowStats: %s', flows)
```

```
class ryu.ofproto.ofproto_v1_0_parser.OFPAggregateStatsRequest (datapath, flags,
                                                                match, table_id,
                                                                out_port)
```

Aggregate flow statistics request message

The controller uses this message to query aggregate flow statistics.

Attribute	Description
flags	Zero (none yet defined in the spec).
match	Fields to match.
table_id	ID of table to read (from ofp_table_stats) 0xff for all tables or 0xfe for emergency.
out_port	Require matching entries to include this as an output port. A value of OFPP_NONE indicates no restriction.

Example:

```
def send_aggregate_stats_request(self, datapath):
    ofp = datapath.ofproto
    ofp_parser = datapath.ofproto_parser

    cookie = cookie_mask = 0
```

```

match = ofp_parser.OFPMatch(in_port=1)
req = ofp_parser.OFPAggregateStatsRequest(
    datapath, 0, match, 0xff, ofp.OFPP_NONE)

datapath.send_msg(req)

```

class `ryu.ofproto.ofproto_v1_0_parser.OFPAggregateStatsReply` (*datapath*)
Aggregate flow statistics reply message

The switch responds with a stats reply that include this message to an aggregate flow statistics request.

Attribute	Description
packet_count	Number of packets in flows.
byte_count	Number of bytes in flows.
flow_count	Number of flows.

Example:

```

@set_ev_cls(ofp_event.EventOFPAggregateStatsReply, MAIN_DISPATCHER)
def aggregate_stats_reply_handler(self, ev):
    msg = ev.msg
    ofp = msg.datapath.ofproto
    body = ev.msg.body

    self.logger.debug('AggregateStats: packet_count=%d byte_count=%d '
                      'flow_count=%d',
                      body.packet_count, body.byte_count,
                      body.flow_count)

```

class `ryu.ofproto.ofproto_v1_0_parser.OFPTableStatsRequest` (*datapath, flags*)
Table statistics request message

The controller uses this message to query flow table statistics.

Attribute	Description
flags	Zero (none yet defined in the spec).

Example:

```

def send_table_stats_request(self, datapath):
    ofp_parser = datapath.ofproto_parser

    req = ofp_parser.OFPTableStatsRequest(datapath)
    datapath.send_msg(req)

```

class `ryu.ofproto.ofproto_v1_0_parser.OFPTableStatsReply` (*datapath*)
Table statistics reply message

The switch responds with a stats reply that include this message to a table statistics request.

Attribute	Description
table_id	ID of table.
name	table name.
wildcards	Bitmap of OFPFW_* wildcards that are supported by the table.
max_entries	Max number of entries supported
active_count	Number of active entries
lookup_count	Number of packets looked up in table
matched_count	Number of packets that hit table

Example:

```
@set_ev_cls(ofp_event.EventOFPTableStatsReply, MAIN_DISPATCHER)
def stats_reply_handler(self, ev):
    msg = ev.msg
    ofp = msg.datapath.ofproto
    body = ev.msg.body

    tables = []
    for stat in body:
        tables.append('table_id=%d name=%s wildcards=0x%02x '
                     'max_entries=%d active_count=%d '
                     'lookup_count=%d matched_count=%d' %
                     (stat.table_id, stat.name, stat.wildcards,
                      stat.max_entries, stat.active_count,
                      stat.lookup_count, stat.matched_count))
    self.logger.debug('TableStats: %s', tables)
```

class ryu.ofproto.ofproto_v1_0_parser.OFPPortStatsRequest (datapath, flags, port_no)
 Port statistics request message

The controller uses this message to query information about ports statistics.

Attribute	Description
flags	Zero (none yet defined in the spec).
port_no	Port number to read (OFPP_NONE to all ports).

Example:

```
def send_port_stats_request(self, datapath):
    ofp = datapath.ofproto
    ofp_parser = datapath.ofproto_parser

    req = ofp_parser.OFPPortStatsRequest(datapath, 0, ofp.OFPP_ANY)
    datapath.send_msg(req)
```

class ryu.ofproto.ofproto_v1_0_parser.OFPPortStatsReply (datapath)
 Port statistics reply message

The switch responds with a stats reply that include this message to a port statistics request.

Attribute	Description
port_no	Port number.
rx_packets	Number of received packets.
tx_packets	Number of transmitted packets.
rx_bytes	Number of received bytes.
tx_bytes	Number of transmitted bytes.
rx_dropped	Number of packets dropped by RX.
tx_dropped	Number of packets dropped by TX.
rx_errors	Number of receive errors.
tx_errors	Number of transmit errors.
rx_frame_err	Number of frame alignment errors.
rx_over_err	Number of packet with RX overrun.
rx_crc_err	Number of CRC errors.
collisions	Number of collisions.

Example:

```
@set_ev_cls(ofp_event.EventOFPPortStatsReply, MAIN_DISPATCHER)
def port_stats_reply_handler(self, ev):
    msg = ev.msg
```

```

ofp = msg.datapath.ofproto
body = ev.msg.body

ports = []
for stat in body:
    ports.append('port_no=%d '
                 'rx_packets=%d tx_packets=%d '
                 'rx_bytes=%d tx_bytes=%d '
                 'rx_dropped=%d tx_dropped=%d '
                 'rx_errors=%d tx_errors=%d '
                 'rx_frame_err=%d rx_over_err=%d rx_crc_err=%d '
                 'collisions=%d' %
                 (stat.port_no,
                  stat.rx_packets, stat.tx_packets,
                  stat.rx_bytes, stat.tx_bytes,
                  stat.rx_dropped, stat.tx_dropped,
                  stat.rx_errors, stat.tx_errors,
                  stat.rx_frame_err, stat.rx_over_err,
                  stat.rx_crc_err, stat.collisions))
self.logger.debug('PortStats: %s', ports)

```

class ryu.ofproto.ofproto_v1_0_parser.OFPQueueStatsRequest (datapath, flags, port_no, queue_id)

Queue statistics request message

The controller uses this message to query queue statistics.

Attribute	Description
flags	Zero (none yet defined in the spec)
port_no	Port number to read (All ports if OFPT_ALL).
queue_id	ID of queue to read (All queues if OFPQ_ALL).

Example:

```

def send_queue_stats_request(self, datapath):
    ofp = datapath.ofproto
    ofp_parser = datapath.ofproto_parser

    req = ofp_parser.OFPQueueStatsRequest(datapath, 0, ofp.OFPT_ALL,
                                           ofp.OFPQ_ALL)
    datapath.send_msg(req)

```

class ryu.ofproto.ofproto_v1_0_parser.OFPQueueStatsReply (datapath)

Queue statistics reply message

The switch responds with a stats reply that include this message to an aggregate flow statistics request.

Attribute	Description
port_no	Port number.
queue_id	ID of queue.
tx_bytes	Number of transmitted bytes.
tx_packets	Number of transmitted packets.
tx_errors	Number of packets dropped due to overrun.

Example:

```

@set_ev_cls(ofp_event.EventOFPQueueStatsReply, MAIN_DISPATCHER)
def stats_reply_handler(self, ev):
    msg = ev.msg
    ofp = msg.datapath.ofproto

```

```

body = ev.msg.body

queues = []
for stat in body:
    queues.append('port_no=%d queue_id=%d '
                  'tx_bytes=%d tx_packets=%d tx_errors=%d ' %
                  (stat.port_no, stat.queue_id,
                   stat.tx_bytes, stat.tx_packets, stat.tx_errors))
self.logger.debug('QueueStats: %s', queues)

```

class ryu.ofproto.ofproto_v1_0_parser.**OFPPVendorStatsRequest** (*datapath, flags, vendor, specific_data=None*)

Vendor statistics request message

The controller uses this message to query vendor-specific information of a switch.

class ryu.ofproto.ofproto_v1_0_parser.**OFPPVendorStatsReply** (*datapath*)

Vendor statistics reply message

The switch responds with a stats reply that include this message to an vendor statistics request.

Send Packet Message

class ryu.ofproto.ofproto_v1_0_parser.**OFPPPacketOut** (*datapath, in_port=None, data=None, buffer_id=None, actions=None*)

Packet-Out message

The controller uses this message to send a packet out through the switch.

Attribute	Description
buffer_id	ID assigned by datapath (0xffffffff if none).
in_port	Packet's input port (OFPP_NONE if none).
actions	ist of OFPAction* instance.
data	Packet data.

Example:

```

def send_packet_out(self, datapath):
    ofp = datapath.ofproto
    ofp_parser = datapath.ofproto_parser

    buffer_id = 0xffffffff
    in_port = ofp.OFPP_NONE
    actions = [ofp_parser.OFPActionOutput(ofp.OFPP_FLOOD, 0)]
    req = ofp_parser.OFPPacketOut(datapath, buffer_id,
                                   in_port, actions)

    datapath.send_msg(req)

```

JSON Example:

```

{
  "OFPPacketOut": {
    "actions": [
      {
        "OFPActionOutput": {
          "max_len": 65535,
          "port": 65532
        }
      }
    ]
  }
}

```



```

    }
    ],
    "buffer_id": 4294967295,
    "data": "8guk0D9w8gukffjqCABFAABU+BoAAP8Br4sKAAABCgAAAggAAgj3YAAAMdYCAAAAAACrjS0xAAAAABARE",
    "in_port": 65533
  }
}

```

Barrier Message

class ryu.ofproto.ofproto_v1_0_parser.**OFPPBarrierRequest** (*datapath*)

Barrier request message

The controller sends this message to ensure message dependencies have been met or receive notifications for completed operations.

Example:

```

def send_barrier_request(self, datapath):
    ofp_parser = datapath.ofproto_parser

    req = ofp_parser.OFPBarrierRequest(datapath)
    datapath.send_msg(req)

```

class ryu.ofproto.ofproto_v1_0_parser.**OFPPBarrierReply** (*datapath*)

Barrier reply message

The switch responds with this message to a barrier request.

Example:

```

@set_ev_cls(ofp_event.EventOFPBarrierReply, MAIN_DISPATCHER)
def barrier_reply_handler(self, ev):
    self.logger.debug('OFPBarrierReply received')

```

Asynchronous Messages

Packet-In Message

class ryu.ofproto.ofproto_v1_0_parser.**OFPPacketIn** (*datapath*, *buffer_id=None*, *total_len=None*, *in_port=None*, *reason=None*, *data=None*)

Packet-In message

The switch sends the packet that received to the controller by this message.

Attribute	Description
buffer_id	ID assigned by datapath.
total_len	Full length of frame.
in_port	Port on which frame was received.
reason	Reason packet is being sent. OFPR_NO_MATCH OFPR_ACTION OFPR_INVALID_TTL
data	Ethernet frame.

Example:

```
@set_ev_cls(ofp_event.EventOFPPacketIn, MAIN_DISPATCHER)
def packet_in_handler(self, ev):
    msg = ev.msg
    dp = msg.datapath
    ofp = dp.ofproto

    if msg.reason == ofp.OFPR_NO_MATCH:
        reason = 'NO MATCH'
    elif msg.reason == ofp.OFPR_ACTION:
        reason = 'ACTION'
    elif msg.reason == ofp.OFPR_INVALID_TTL:
        reason = 'INVALID TTL'
    else:
        reason = 'unknown'

    self.logger.debug('OFPPacketIn received: '
                      'buffer_id=%x total_len=%d in_port=%d, '
                      'reason=%s data=%s',
                      msg.buffer_id, msg.total_len, msg.in_port,
                      reason, utils.hex_array(msg.data))
```

JSON Example:

```
{
  "OFPPacketIn": {
    "buffer_id": 2,
    "data": "/////////8gukffjqCAYAAQgABgQAAfILpH346goAAAEAAAAAAAAAKAAAD",
    "in_port": 99,
    "reason": 1,
    "total_len": 42
  }
}
```

Flow Removed Message

class ryu.ofproto.ofproto_v1_0_parser.OFPFlowRemoved(*datapath*)
Flow removed message

When flow entries time out or are deleted, the switch notifies controller with this message.

Attribute	Description
match	Instance of <code>OFPMatch</code> .
cookie	Opaque controller-issued identifier.
priority	Priority level of flow entry.
reason	One of the following values. OFPRR_IDLE_TIMEOUT OFPRR_HARD_TIMEOUT OFPRR_DELETE
duration_sec	Time flow was alive in seconds.
duration_nsec	Time flow was alive in nanoseconds beyond duration_sec.
idle_timeout	Idle timeout from original flow mod.
packet_count	Number of packets that was associated with the flow.
byte_count	Number of bytes that was associated with the flow.

Example:

```
@set_ev_cls(ofp_event.EventOFPPFlowRemoved, MAIN_DISPATCHER)
def flow_removed_handler(self, ev):
    msg = ev.msg
    dp = msg.datapath
    ofp = dp.ofproto

    if msg.reason == ofp.OFPRR_IDLE_TIMEOUT:
        reason = 'IDLE TIMEOUT'
    elif msg.reason == ofp.OFPRR_HARD_TIMEOUT:
        reason = 'HARD TIMEOUT'
    elif msg.reason == ofp.OFPRR_DELETE:
        reason = 'DELETE'
    elif msg.reason == ofp.OFPRR_GROUP_DELETE:
        reason = 'GROUP DELETE'
    else:
        reason = 'unknown'

    self.logger.debug('OFPPFlowRemoved received: '
                      'match=%s cookie=%d priority=%d reason=%s '
                      'duration_sec=%d duration_nsec=%d '
                      'idle_timeout=%d packet_count=%d byte_count=%d',
                      msg.match, msg.cookie, msg.priority, reason,
                      msg.duration_sec, msg.duration_nsec,
                      msg.idle_timeout, msg.packet_count,
                      msg.byte_count)
```

Port Status Message

```
class ryu.ofproto.ofproto_v1_0_parser.OFPPortStatus(datapath, reason=None,
                                                    desc=None)
```

Port status message

The switch notifies controller of change of ports.

Attribute	Description
reason	One of the following values. OFPPR_ADD OFPPR_DELETE OFPPR_MODIFY
desc	instance of OFPPhyPort

Example:

```
@set_ev_cls(ofp_event.EventOFPPortStatus, MAIN_DISPATCHER)
def port_status_handler(self, ev):
    msg = ev.msg
    dp = msg.datapath
    ofp = dp.ofproto

    if msg.reason == ofp.OFPPR_ADD:
        reason = 'ADD'
    elif msg.reason == ofp.OFPPR_DELETE:
        reason = 'DELETE'
    elif msg.reason == ofp.OFPPR_MODIFY:
        reason = 'MODIFY'
    else:
        reason = 'unknown'

    self.logger.debug('OFPPortStatus received: reason=%s desc=%s',
                      reason, msg.desc)
```

Error Message

`class ryu.ofproto.ofproto_v1_0_parser.OFPErrormsg(datapath, type=None, code=None, data=None)`

Error message

The switch notifies controller of problems by this message.

Attribute	Description
type	High level type of error
code	Details depending on the type
data	Variable length data depending on the type and code

type attribute corresponds to type_ parameter of `__init__`.

Types and codes are defined in `ryu.ofproto.ofproto`.

Type	Code
OFPET_HELLO_FAILED	OFPHFC_*
OFPET_BAD_REQUEST	OFPBRC_*
OFPET_BAD_ACTION	OFPBAC_*
OFPET_FLOW_MOD_FAILED	OFPFMFC_*
OFPET_PORT_MOD_FAILED	OFPPMFC_*
OFPET_QUEUE_OP_FAILED	OFPQOFC_*

Example:

```
@set_ev_cls(ofp_event.EventOFPErrormsg,
            [HANDSHAKE_DISPATCHER, CONFIG_DISPATCHER, MAIN_DISPATCHER])
```

```
def error_msg_handler(self, ev):
    msg = ev.msg

    self.logger.debug('OFPErrormsg received: type=0x%02x code=0x%02x '
                      'message=%s',
                      msg.type, msg.code, utils.hex_array(msg.data))
```

Symmetric Messages

Hello

class ryu.ofproto.ofproto_v1_0_parser.**OFPHello** (*datapath*)
Hello message

When connection is started, the hello message is exchanged between a switch and a controller.

This message is handled by the Ryu framework, so the Ryu application do not need to process this typically.

Echo Request

class ryu.ofproto.ofproto_v1_0_parser.**OFPEchoRequest** (*datapath*, *data=None*)
Echo request message

This message is handled by the Ryu framework, so the Ryu application do not need to process this typically.

Attribute	Description
data	An arbitrary length data.

Example:

```
def send_echo_request(self, datapath, data):
    ofp_parser = datapath.ofproto_parser

    req = ofp_parser.OFPEchoRequest(datapath, data)
    datapath.send_msg(req)
```

Echo Reply

class ryu.ofproto.ofproto_v1_0_parser.**OFPEchoReply** (*datapath*, *data=None*)
Echo reply message

This message is handled by the Ryu framework, so the Ryu application do not need to process this typically.

Attribute	Description
data	An arbitrary length data.

Example:

```
@set_ev_cls(ofp_event.EventOFPEchoReply,
            [HANDSHAKE_DISPATCHER, CONFIG_DISPATCHER, MAIN_DISPATCHER])
def echo_reply_handler(self, ev):
    self.logger.debug('OFPEchoReply received: data=%s',
                      utils.hex_array(ev.msg.data))
```

Vendor

class ryu.ofproto.ofproto_v1_0_parser.**OFPPVendor** (*datapath*)
Vendor message

The controller send this message to send the vendor-specific information to a switch.

Port Structures

class ryu.ofproto.ofproto_v1_0_parser.**OFPPhyPort**
Description of a port

Attribute	Description
port_no	Port number and it uniquely identifies a port within a switch.
hw_addr	MAC address for the port.
name	Null-terminated string containing a human-readable name for the interface.
config	Bitmap of port configuration flags. OFPPC_PORT_DOWN OFPPC_NO_STP OFPPC_NO_RECV OFPPC_NO_RECV_STP OFPPC_NO_FLOOD OFPPC_NO_FWD OFPPC_NO_PACKET_IN
state	Bitmap of port state flags. OFPPS_LINK_DOWN OFPPS_STP_LISTEN OFPPS_STP_LEARN OFPPS_STP_FORWARD OFPPS_STP_BLOCK OFPPS_STP_MASK
curr	Current features.
advertised	Features being advertised by the port.
supported	Features supported by the port.
peer	Features advertised by peer.

Flow Match Structure

```
class ryu.ofproto.ofproto_v1_0_parser.OFPMatch (wildcards=None, in_port=None,
                                                dl_src=None, dl_dst=None,
                                                dl_vlan=None, dl_vlan_pcp=None,
                                                dl_type=None, nw_tos=None,
                                                nw_proto=None, nw_src=None,
                                                nw_dst=None, tp_src=None, tp_dst=None,
                                                nw_src_mask=32, nw_dst_mask=32)
```

Flow Match Structure

This class is implementation of the flow match structure having compose/query API.

Attribute	Description
wildcards	Wildcard fields.
(match fields)	For the available match fields, please refer to the following.

Argument	Value	Description
in_port	Integer 16bit	Switch input port.
dl_src	MAC address	Ethernet source address.
dl_dst	MAC address	Ethernet destination address.
dl_vlan	Integer 16bit	Input VLAN id.
dl_vlan_pcp	Integer 8bit	Input VLAN priority.
dl_type	Integer 16bit	Ethernet frame type.
nw_tos	Integer 8bit	IP ToS (actually DSCP field, 6 bits).
nw_proto	Integer 8bit	IP protocol or lower 8 bits of ARP opcode.
nw_src	IPv4 address	IP source address.
nw_dst	IPv4 address	IP destination address.
tp_src	Integer 16bit	TCP/UDP source port.
tp_dst	Integer 16bit	TCP/UDP destination port.
nw_src_mask	Integer 8bit	IP source address mask specified as IPv4 address prefix.
nw_dst_mask	Integer 8bit	IP destination address mask specified as IPv4 address prefix.

Example:

```
>>> # compose
>>> match = parser.OFPMatch(
...     in_port=1,
...     dl_type=0x0800,
...     dl_src='aa:bb:cc:dd:ee:ff',
...     nw_src='192.168.0.1')
>>> # query
>>> if 'nw_src' in match:
...     print match['nw_src']
...
'192.168.0.1'
```

Action Structures

```
class ryu.ofproto.ofproto_v1_0_parser.OFPActionHeader (type_, len_)
```

```
class ryu.ofproto.ofproto_v1_0_parser.OFPAction
```

```
class ryu.ofproto.ofproto_v1_0_parser.OFPActionOutput (port, max_len=65509)
Output action
```

This action indicates output a packet to the switch port.

Attribute	Description
port	Output port.
max_len	Max length to send to controller.

Note:: The reason of this magic number (0xffe5) is because there is no good constant in of1.0. The same value as OFPCML_MAX of of1.2 and of1.3 is used.

class ryu.ofproto.ofproto_v1_0_parser.OFPActionVlanVid (*vlan_vid*)
Set the 802.1q VLAN id action

This action indicates the 802.1q VLAN id to be set.

Attribute	Description
vlan_vid	VLAN id.

class ryu.ofproto.ofproto_v1_0_parser.OFPActionVlanPcp (*vlan_pcp*)
Set the 802.1q priority action

This action indicates the 802.1q priority to be set.

Attribute	Description
vlan_pcp	VLAN priority.

class ryu.ofproto.ofproto_v1_0_parser.OFPActionStripVlan
Strip the 802.1q header action

This action indicates the 802.1q priority to be striped.

class ryu.ofproto.ofproto_v1_0_parser.OFPActionDlAddr (*dl_addr*)

class ryu.ofproto.ofproto_v1_0_parser.OFPActionSetDlSrc (*dl_addr*)
Set the ethernet source address action

This action indicates the ethernet source address to be set.

Attribute	Description
dl_addr	Ethernet address.

class ryu.ofproto.ofproto_v1_0_parser.OFPActionSetDlDst (*dl_addr*)
Set the ethernet destination address action

This action indicates the ethernet destination address to be set.

Attribute	Description
dl_addr	Ethernet address.

class ryu.ofproto.ofproto_v1_0_parser.OFPActionNwAddr (*nw_addr*)

class ryu.ofproto.ofproto_v1_0_parser.OFPActionSetNwSrc (*nw_addr*)
Set the IP source address action

This action indicates the IP source address to be set.

Attribute	Description
nw_addr	IP address.

class ryu.ofproto.ofproto_v1_0_parser.OFPActionSetNwDst (*nw_addr*)
Set the IP destination address action

This action indicates the IP destination address to be set.

Attribute	Description
nw_addr	IP address.

class `ryu.ofproto.ofproto_v1_0_parser.OFPActionSetNwTos` (*tos*)
Set the IP ToS action

This action indicates the IP ToS (DSCP field, 6 bits) to be set.

Attribute	Description
tos	IP ToS (DSCP field, 6 bits).

class `ryu.ofproto.ofproto_v1_0_parser.OFPActionTpPort` (*tp*)

class `ryu.ofproto.ofproto_v1_0_parser.OFPActionSetTpSrc` (*tp*)
Set the TCP/UDP source port action

This action indicates the TCP/UDP source port to be set.

Attribute	Description
tp	TCP/UDP port.

class `ryu.ofproto.ofproto_v1_0_parser.OFPActionSetTpDst` (*tp*)
Set the TCP/UDP destination port action

This action indicates the TCP/UDP destination port to be set.

Attribute	Description
tp	TCP/UDP port.

class `ryu.ofproto.ofproto_v1_0_parser.OFPActionEnqueue` (*port, queue_id*)
Output to queue action

This action indicates send packets to given queue on port.

Attribute	Description
port	Port that queue belongs.
queue_id	Where to enqueue the packets.

class `ryu.ofproto.ofproto_v1_0_parser.OFPActionVendor`
Vendor action

This action is an extensible action for the vendor.

2.5.3 OpenFlow v1.2 Messages and Structures

Controller-to-Switch Messages

Handshake

class `ryu.ofproto.ofproto_v1_2_parser.OFPFeaturesRequest` (*datapath*)
Features request message

The controller sends a feature request to the switch upon session establishment.

This message is handled by the Ryu framework, so the Ryu application do not need to process this typically.

Example:

```
def send_features_request(self, datapath):
    ofp_parser = datapath.ofproto_parser

    req = ofp_parser.OFPFeaturesRequest(datapath)
    datapath.send_msg(req)
```

JSON Example:

```
{
  "OFPPortFeaturesRequest": {}
}
```

`class ryu.ofproto.ofproto_v1_2_parser.OFPSwitchFeatures` (*datapath*, *datapath_id=None*, *n_buffers=None*, *n_tables=None*, *capabilities=None*, *ports=None*)

Features reply message

The switch responds with a features reply message to a features request.

This message is handled by the Ryu framework, so the Ryu application do not need to process this typically.

Example:

```
@set_ev_cls(ofp_event.EventOFPSwitchFeatures, CONFIG_DISPATCHER)
def switch_features_handler(self, ev):
    msg = ev.msg

    self.logger.debug('OFPSwitchFeatures received: '
                      'datapath_id=0x%016x n_buffers=%d '
                      'n_tables=%d capabilities=0x%08x ports=%s',
                      msg.datapath_id, msg.n_buffers, msg.n_tables,
                      msg.capabilities, msg.ports)
```

JSON Example:

```
{
  "OFPSwitchFeatures": {
    "capabilities": 79,
    "datapath_id": 9210263729383,
    "n_buffers": 0,
    "n_tables": 255,
    "ports": {
      "6": {
        "OFPPort": {
          "advertised": 10240,
          "config": 0,
          "curr": 10248,
          "curr_speed": 5000,
          "hw_addr": "f2:0b:a4:7d:f8:ea",
          "max_speed": 5000,
          "name": "Port6",
          "peer": 10248,
          "port_no": 6,
          "state": 4,
          "supported": 10248
        }
      },
      "7": {
        "OFPPort": {
          "advertised": 10240,
          "config": 0,
          "curr": 10248,
          "curr_speed": 5000,
          "hw_addr": "f2:0b:a4:d0:3f:70",
          "max_speed": 5000,

```

```

        "name": "Port7",
        "peer": 10248,
        "port_no": 7,
        "state": 4,
        "supported": 10248
    }
}
}
}
}

```

Switch Configuration

class ryu.ofproto.ofproto_v1_2_parser.**OFPSetsConfig** (*datapath, flags=0, miss_send_len=0*)
 Set config request message

The controller sends a set config request message to set configuration parameters.

Attribute	Description
flags	One of the following configuration flags. OFPC_FRAG_NORMAL OFPC_FRAG_DROP OFPC_FRAG_REASM OFPC_FRAG_MASK OFPC_INVALID_TTL_TO_CONTROLLER
miss_send_len	Max bytes of new flow that datapath should send to the controller

Example:

```

def send_set_config(self, datapath):
    ofp = datapath.ofproto
    ofp_parser = datapath.ofproto_parser

    req = ofp_parser.OFPSetsConfig(datapath, ofp.OFPC_FRAG_NORMAL, 256)
    datapath.send_msg(req)

```

JSON Example:

```

{
  "OFPSetsConfig": {
    "flags": 0,
    "miss_send_len": 128
  }
}

```

class ryu.ofproto.ofproto_v1_2_parser.**OFPSetsConfigRequest** (*datapath*)
 Get config request message

The controller sends a get config request to query configuration parameters in the switch.

Example:

```

def send_get_config_request(self, datapath):
    ofp_parser = datapath.ofproto_parser

```

```
req = ofp_parser.OFPGetConfigRequest(datapath)
datapath.send_msg(req)
```

JSON Example:

```
{
  "OFPGetConfigRequest": {}
}
```

class ryu.ofproto.ofproto_v1_2_parser.**OFPGetConfigReply** (*datapath*, *flags=None*, *miss_send_len=None*)

Get config reply message

The switch responds to a configuration request with a get config reply message.

Attribute	Description
flags	One of the following configuration flags. OFPC_FRAG_NORMAL OFPC_FRAG_DROP OFPC_FRAG_REASM OFPC_FRAG_MASK OFPC_INVALID_TTL_TO_CONTROLLER
miss_send_len	Max bytes of new flow that datapath should send to the controller

Example:

```
@set_ev_cls(ofp_event.EventOFPGetConfigReply, MAIN_DISPATCHER)
def get_config_reply_handler(self, ev):
    msg = ev.msg
    dp = msg.datapath
    ofp = dp.ofproto

    if msg.flags == ofp.OFPC_FRAG_NORMAL:
        flags = 'NORMAL'
    elif msg.flags == ofp.OFPC_FRAG_DROP:
        flags = 'DROP'
    elif msg.flags == ofp.OFPC_FRAG_REASM:
        flags = 'REASM'
    elif msg.flags == ofp.OFPC_FRAG_MASK:
        flags = 'MASK'
    elif msg.flags == ofp.OFPC_INVALID_TTL_TO_CONTROLLER:
        flags = 'INVALID TTL TO CONTROLLER'
    else:
        flags = 'unknown'
    self.logger.debug('OFPGetConfigReply received: '
                      'flags=%s miss_send_len=%d',
                      flags, msg.miss_send_len)
```

JSON Example:

```
{
  "OFPGetConfigReply": {
    "flags": 0,
    "miss_send_len": 128
  }
}
```

```

    }
}

```

Flow Table Configuration

class ryu.ofproto.ofproto_v1_2_parser.**OFPTTableMod** (*datapath, table_id, config*)
 Flow table configuration message

The controller sends this message to configure table state.

Attribute	Description
table_id	ID of the table (OFPTT_ALL indicates all tables)
config	Bitmap of the following flags. OFPTC_TABLE_MISS_CONTROLLER OFPTC_TABLE_MISS_CONTINUE OFPTC_TABLE_MISS_DROP OFPTC_TABLE_MISS_MASK

Example:

```

def send_table_mod(self, datapath):
    ofp = datapath.ofproto
    ofp_parser = datapath.ofproto_parser

    req = ofp_parser.OFPTTableMod(datapath, ofp.OFPTT_ALL,
                                   ofp.OFPTC_TABLE_MISS_DROP)

    datapath.send_msg(req)

```

JSON Example:

```

{
  "OFPTTableMod": {
    "config": 0,
    "table_id": 255
  }
}

```

Modify State Messages

class ryu.ofproto.ofproto_v1_2_parser.**OFPFLOWMod** (*datapath, cookie=0, cookie_mask=0, table_id=0, command=0, idle_timeout=0, hard_timeout=0, priority=0, buffer_id=4294967295, out_port=0, out_group=0, flags=0, match=None, instructions=None*)

Modify Flow entry message

The controller sends this message to modify the flow table.

Attribute	Description
cookie	Opaque controller-issued identifier
cookie_mask	Mask used to restrict the cookie bits that must match when the command is <code>OPFFC_MODIFY*</code> or <code>OPFFC_DELETE*</code>
table_id	ID of the table to put the flow in
command	One of the following values. <code>OPFFC_ADD</code> <code>OPFFC_MODIFY</code> <code>OPFFC_MODIFY_STRICT</code> <code>OPFFC_DELETE</code> <code>OPFFC_DELETE_STRICT</code>
idle_timeout	Idle time before discarding (seconds)
hard_timeout	Max time before discarding (seconds)
priority	Priority level of flow entry
buffer_id	Buffered packet to apply to (or <code>OPF_NO_BUFFER</code>)
out_port	For <code>OPFFC_DELETE*</code> commands, require matching entries to include this as an output port
out_group	For <code>OPFFC_DELETE*</code> commands, require matching entries to include this as an output group
flags	One of the following values. <code>OPFFF_SEND_FLOW_REM</code> <code>OPFFF_CHECK_OVERLAP</code> <code>OPFFF_RESET_COUNTS</code>
match	Instance of <code>OFPMatch</code>
instructions	list of <code>OFPIinstruction*</code> instance

Example:

```
def send_flow_mod(self, datapath):
    ofp = datapath.ofproto
    ofp_parser = datapath.ofproto_parser

    cookie = cookie_mask = 0
    table_id = 0
    idle_timeout = hard_timeout = 0
    priority = 32768
    buffer_id = ofp.OPF_NO_BUFFER
    match = ofp_parser.OFPMatch(in_port=1, eth_dst='ff:ff:ff:ff:ff:ff')
    actions = [ofp_parser.OFPActionOutput(ofp.OFPP_NORMAL, 0)]
    inst = [ofp_parser.OFPInstructionActions(ofp.OFPIT_APPLY_ACTIONS,
                                           actions)]
    req = ofp_parser.OFPFlowMod(datapath, cookie, cookie_mask,
                                table_id, ofp.OPFFC_ADD,
                                idle_timeout, hard_timeout,
                                priority, buffer_id,
                                ofp.OFPP_ANY, ofp.OFPG_ANY,
                                ofp.OPFFF_SEND_FLOW_REM,
                                match, inst)

    datapath.send_msg(req)
```

JSON Example:

```

{
  "OFPPFlowMod": {
    "buffer_id": 65535,
    "command": 0,
    "cookie": 0,
    "cookie_mask": 0,
    "flags": 0,
    "hard_timeout": 0,
    "idle_timeout": 0,
    "instructions": [
      {
        "OFPIInstructionActions": {
          "actions": [
            {
              "OFPAActionSetField": {
                "field": {
                  "OXMTlv": {
                    "field": "vlan_vid",
                    "mask": null,
                    "value": 258
                  }
                },
                "len": 16,
                "type": 25
              },
              {
                "OFPAActionOutput": {
                  "len": 16,
                  "max_len": 65535,
                  "port": 6,
                  "type": 0
                }
              }
            ],
            "len": 40,
            "type": 3
          }
        },
        {
          "OFPIInstructionActions": {
            "actions": [
              {
                "OFPAActionSetField": {
                  "field": {
                    "OXMTlv": {
                      "field": "eth_src",
                      "mask": null,
                      "value": "01:02:03:04:05:06"
                    }
                  },
                  "len": 16,
                  "type": 25
                }
              }
            ],
            "len": 24,

```

```

        "type": 4
    }
}
],
"match": {
    "OFPMatch": {
        "length": 14,
        "oxm_fields": [
            {
                "OXMTlv": {
                    "field": "eth_dst",
                    "mask": null,
                    "value": "f2:0b:a4:7d:f8:ea"
                }
            }
        ],
        "type": 1
    }
},
"out_group": 4294967295,
"out_port": 4294967295,
"priority": 123,
"table_id": 1
}
}

```

```

{
    "OFPPFlowMod": {
        "buffer_id": 65535,
        "command": 0,
        "cookie": 0,
        "cookie_mask": 0,
        "flags": 0,
        "hard_timeout": 0,
        "idle_timeout": 0,
        "instructions": [
            {
                "OFPIInstructionGotoTable": {
                    "len": 8,
                    "table_id": 1,
                    "type": 1
                }
            }
        ],
        "match": {
            "OFPMatch": {
                "length": 22,
                "oxm_fields": [
                    {
                        "OXMTlv": {
                            "field": "in_port",
                            "mask": null,
                            "value": 6
                        }
                    },
                    {
                        "OXMTlv": {
                            "field": "eth_src",

```



```

        "mask": null,
        "value": "f2:0b:a4:7d:f8:ea"
    }
    ],
    "type": 1
}
},
"out_group": 4294967295,
"out_port": 4294967295,
"priority": 123,
"table_id": 0
}
}

```

class ryu.ofproto.ofproto_v1_2_parser.**OFPGGroupMod**(datapath, command=0, type_=0, group_id=0, buckets=None)

Modify group entry message

The controller sends this message to modify the group table.

Attribute	Description
command	One of the following values. OFPGC_ADD OFPGC_MODIFY OFPGC_DELETE
type	One of the following values. OFPGT_ALL OFPGT_SELECT OFPGT_INDIRECT OFPGT_FF
group_id	Group identifier
buckets	list of OFPBucket

type attribute corresponds to type_ parameter of __init__.

Example:

```

def send_group_mod(self, datapath):
    ofp = datapath.ofproto
    ofp_parser = datapath.ofproto_parser

    port = 1
    max_len = 2000
    actions = [ofp_parser.OFPActionOutput(port, max_len)]

    weight = 100
    watch_port = 0
    watch_group = 0
    buckets = [ofp_parser.OFPBucket(weight, watch_port, watch_group,
                                    actions)]

    group_id = 1
    req = ofp_parser.OFPGGroupMod(datapath, ofp.OFPGC_ADD,

```

```
datapath.send_msg(req) ofp.OFPPT_SELECT, group_id, buckets)
```

JSON Example:

```
{
  "OFPGroupMod": {
    "buckets": [
      {
        "OFPBucket": {
          "actions": [
            {
              "OFPActionOutput": {
                "len": 16,
                "max_len": 65535,
                "port": 2,
                "type": 0
              }
            }
          ]
        },
        "len": 32,
        "watch_group": 1,
        "watch_port": 1,
        "weight": 1
      }
    ]
  },
  "command": 0,
  "group_id": 1,
  "type": 0
}
```

```
class ryu.ofproto.ofproto_v1_2_parser.OFPPortMod(datapath, port_no=0,
                                                  hw_addr='00:00:00:00:00:00',
                                                  config=0, mask=0, advertise=0)
```

Port modification message

The controller sends this message to modify the behavior of the port.

Attribute	Description
port_no	Port number to modify
hw_addr	The hardware address that must be the same as hw_addr of OFPPort of OFPSwitchFeatures
config	Bitmap of configuration flags. OFPPC_PORT_DOWN OFPPC_NO_RECV OFPPC_NO_FWD OFPPC_NO_PACKET_IN
mask	Bitmap of configuration flags above to be changed
advertise	Bitmap of the following flags. OFPPF_10MB_HD OFPPF_10MB_FD OFPPF_100MB_HD OFPPF_100MB_FD OFPPF_1GB_HD OFPPF_1GB_FD OFPPF_10GB_FD OFPPF_40GB_FD OFPPF_100GB_FD OFPPF_1TB_FD OFPPF_OTHER OFPPF_COPPER OFPPF_FIBER OFPPF_AUTONEG OFPPF_PAUSE OFPPF_PAUSE_ASYM

Example:

```
def send_port_mod(self, datapath):
    ofp = datapath.ofproto
    ofp_parser = datapath.ofproto_parser

    port_no = 3
    hw_addr = 'fa:c8:e8:76:1d:7e'
    config = 0
    mask = (ofp.OFPPC_PORT_DOWN | ofp.OFPPC_NO_RECV |
            ofp.OFPPC_NO_FWD | ofp.OFPPC_NO_PACKET_IN)
    advertise = (ofp.OFPPF_10MB_HD | ofp.OFPPF_100MB_FD |
                 ofp.OFPPF_1GB_FD | ofp.OFPPF_COPPER |
                 ofp.OFPPF_AUTONEG | ofp.OFPPF_PAUSE |
                 ofp.OFPPF_PAUSE_ASYM)
    req = ofp_parser.OFPPortMod(datapath, port_no, hw_addr, config,
                                mask, advertise)
    datapath.send_msg(req)
```

JSON Example:

```
{
  "OFPPortMod": {
    "advertise": 4096,
    "config": 0,
    "hw_addr": "00-11-00-00-11-11",
    "mask": 0,
    "port_no": 1
  }
}
```

Read State Messages

class ryu.ofproto.ofproto_v1_2_parser.OFPDescStatsRequest (datapath, flags=0)
Description statistics request message

The controller uses this message to query description of the switch.

Attribute	Description
flags	Zero (none yet defined in the spec)

Example:

```
def send_desc_stats_request(self, datapath):
    ofp_parser = datapath.ofproto_parser

    req = ofp_parser.OFPDescStatsRequest(datapath)
    datapath.send_msg(req)
```

JSON Example:

```
{
  "OFPDescStatsRequest": {
    "flags": 0
  }
}
```

class ryu.ofproto.ofproto_v1_2_parser.OFPDescStats
Description statistics reply message

The switch responds with a stats reply that include this message to a description statistics request.

Attribute	Description
mfr_desc	Manufacturer description
hw_desc	Hardware description
sw_desc	Software description
serial_num	Serial number
dp_desc	Human readable description of datapath

Example:

```
@set_ev_cls(ofp_event.EventOFPStatsReply, MAIN_DISPATCHER)
def stats_reply_handler(self, ev):
    msg = ev.msg
    ofp = msg.datapath.ofproto
    body = ev.msg.body

    if msg.type == ofp.OFPST_DESC:
        self.desc_stats_reply_handler(body)
```

```
def desc_stats_reply_handler(self, body):
    self.logger.debug('DescStats: mfr_desc=%s hw_desc=%s sw_desc=%s '
                      'serial_num=%s dp_desc=%s',
                      body.mfr_desc, body.hw_desc, body.sw_desc,
                      body.serial_num, body.dp_desc)
```

JSON Example:

```
{
  "OFStatsReply": {
    "body": {
      "OFDescStats": {
        "dp_desc": "dp",
        "hw_desc": "hw",
        "mfr_desc": "mfr",
        "serial_num": "serial",
        "sw_desc": "sw"
      }
    },
    "flags": 0,
    "type": 0
  }
}
```

class ryu.ofproto.ofproto_v1_2_parser.OFPFlowStatsRequest (datapath, table_id=255, out_port=4294967295, out_group=4294967295, cookie=0, cookie_mask=0, match=None, flags=0)

Individual flow statistics request message

The controller uses this message to query individual flow statistics.

Attribute	Description
table_id	ID of table to read
out_port	Require matching entries to include this as an output port
out_group	Require matching entries to include this as an output group
cookie	Require matching entries to contain this cookie value
cookie_mask	Mask used to restrict the cookie bits that must match
match	Instance of OFPMatch
flags	Zero (none yet defined in the spec)

Example:

```
def send_flow_stats_request(self, datapath):
    ofp = datapath.ofproto
    ofp_parser = datapath.ofproto_parser

    cookie = cookie_mask = 0
    match = ofp_parser.OFPMatch(in_port=1)
    req = ofp_parser.OFPFlowStatsRequest(datapath,
                                          ofp.OFPPTT_ALL,
                                          ofp.OFPP_ANY, ofp.OFPG_ANY,
                                          cookie, cookie_mask, match)

    datapath.send_msg(req)
```

JSON Example:

```
{
  "OFPPFlowStatsRequest": {
    "cookie": 0,
    "cookie_mask": 0,
    "flags": 0,
    "match": {
      "OFPMatch": {
        "length": 4,
        "oxm_fields": [],
        "type": 1
      }
    },
    "out_group": 4294967295,
    "out_port": 4294967295,
    "table_id": 0
  }
}
```

class ryu.ofproto.ofproto_v1_2_parser.**OFPPFlowStats**(*table_id*, *duration_sec*, *duration_nsec*, *priority*, *idle_timeout*, *hard_timeout*, *cookie*, *packet_count*, *byte_count*, *match*, *instructions=None*, *length=None*)

Individual flow statistics reply message

The switch responds with a stats reply that include this message to an individual flow statistics request.

Attribute	Description
table_id	ID of table flow came from
duration_sec	Time flow has been alive in seconds
duration_nsec	Time flow has been alive in nanoseconds beyond duration_sec
priority	Priority of the entry
idle_timeout	Number of seconds idle before expiration
hard_timeout	Number of seconds before expiration
cookie	Opaque controller-issued identifier
packet_count	Number of packets in flow
byte_count	Number of bytes in flow
match	Instance of OFPMatch
instructions	list of OFPInstruction* instance

Example:

```
@set_ev_cls(ofp_event.EventOFPStatsReply, MAIN_DISPATCHER)
def stats_reply_handler(self, ev):
    msg = ev.msg
    ofp = msg.datapath.ofproto
    body = ev.msg.body

    if msg.type == ofp.OFPST_FLOW:
        self.flow_stats_reply_handler(body)

def flow_stats_reply_handler(self, body):
    flows = []
    for stat in body:
        flows.append('table_id=%s '
                    'duration_sec=%d duration_nsec=%d '
                    'priority=%d '
                    'idle_timeout=%d hard_timeout=%d '
```

```

        'cookie=%d packet_count=%d byte_count=%d '
        'match=%s instructions=%s' %
        (stat.table_id,
         stat.duration_sec, stat.duration_nsec,
         stat.priority,
         stat.idle_timeout, stat.hard_timeout,
         stat.cookie, stat.packet_count, stat.byte_count,
         stat.match, stat.instructions)
self.logger.debug('FlowStats: %s', flows)

```

JSON Example:

```

{
  "OFStatsReply": {
    "body": [
      {
        "OFFlowStats": {
          "byte_count": 0,
          "cookie": 0,
          "duration_nsec": 115277000,
          "duration_sec": 358,
          "hard_timeout": 0,
          "idle_timeout": 0,
          "instructions": [],
          "length": 56,
          "match": {
            "OFMatch": {
              "length": 4,
              "oxm_fields": [],
              "type": 1
            }
          },
          "packet_count": 0,
          "priority": 65535,
          "table_id": 0
        }
      },
      {
        "OFFlowStats": {
          "byte_count": 0,
          "cookie": 0,
          "duration_nsec": 115055000,
          "duration_sec": 358,
          "hard_timeout": 0,
          "idle_timeout": 0,
          "instructions": [
            {
              "OFInstructionActions": {
                "actions": [
                  {
                    "OFActionOutput": {
                      "len": 16,
                      "max_len": 0,
                      "port": 4294967290,
                      "type": 0
                    }
                  }
                ]
              }
            }
          ]
        }
      }
    ]
  }
}

```

```

        "len": 24,
        "type": 4
    }
}
],
"length": 88,
"match": {
    "OFPMatch": {
        "length": 10,
        "oxm_fields": [
            {
                "OXMTlv": {
                    "field": "eth_type",
                    "mask": null,
                    "value": 2054
                }
            }
        ],
        "type": 1
    }
},
"packet_count": 0,
"priority": 65534,
"table_id": 0
}
},
{
    "OFPPFlowStats": {
        "byte_count": 238,
        "cookie": 0,
        "duration_nsec": 511582000,
        "duration_sec": 316220,
        "hard_timeout": 0,
        "idle_timeout": 0,
        "instructions": [
            {
                "OFPIInstructionGotoTable": {
                    "len": 8,
                    "table_id": 1,
                    "type": 1
                }
            }
        ],
        "length": 80,
        "match": {
            "OFPMatch": {
                "length": 22,
                "oxm_fields": [
                    {
                        "OXMTlv": {
                            "field": "in_port",
                            "mask": null,
                            "value": 6
                        }
                    }
                ],
                "type": 1
            },
            {
                "OXMTlv": {
                    "field": "eth_src",

```



```

        "mask": null,
        "value": "f2:0b:a4:7d:f8:ea"
    }
    ],
    "type": 1
}
},
"packet_count": 3,
"priority": 123,
"table_id": 0
}
},
{
  "OFPPFlowStats": {
    "byte_count": 98,
    "cookie": 0,
    "duration_nsec": 980901000,
    "duration_sec": 313499,
    "hard_timeout": 0,
    "idle_timeout": 0,
    "instructions": [
      {
        "OFPIInstructionActions": {
          "actions": [
            {
              "OFPAActionOutput": {
                "len": 16,
                "max_len": 65535,
                "port": 4294967293,
                "type": 0
              }
            }
          ],
          "len": 24,
          "type": 3
        }
      }
    ],
    "length": 80,
    "match": {
      "OFPMatch": {
        "length": 4,
        "oxm_fields": [],
        "type": 1
      }
    },
    "packet_count": 1,
    "priority": 0,
    "table_id": 0
  }
}
},
"flags": 0,
"type": 1
}
}

```

```
class ryu.ofproto.ofproto_v1_2_parser.OFPAggregateStatsRequest (datapath,
                                                                table_id=255,
                                                                out_port=4294967295,
                                                                out_group=4294967295,
                                                                cookie=0,
                                                                cookie_mask=0,
                                                                match=None,
                                                                flags=0)
```

Aggregate flow statistics request message

The controller uses this message to query aggregate flow statistics.

Attribute	Description
table_id	ID of table to read
out_port	Require matching entries to include this as an output port
out_group	Require matching entries to include this as an output group
cookie	Require matching entries to contain this cookie value
cookie_mask	Mask used to restrict the cookie bits that must match
match	Instance of OFPMatch
flags	Zero (none yet defined in the spec)

Example:

```
def send_aggregate_stats_request(self, datapath):
    ofp = datapath.ofproto
    ofp_parser = datapath.ofproto_parser

    cookie = cookie_mask = 0
    match = ofp_parser.OFPMatch(in_port=1)
    req = ofp_parser.OFPAggregateStatsRequest (datapath, 0,
                                                ofp.OFPTT_ALL,
                                                ofp.OFPP_ANY,
                                                ofp.OFPG_ANY,
                                                cookie, cookie_mask,
                                                match)

    datapath.send_msg(req)
```

JSON Example:

```
{
  "OFPAggregateStatsRequest": {
    "cookie": 0,
    "cookie_mask": 0,
    "flags": 0,
    "match": {
      "OFPMatch": {
        "length": 4,
        "oxm_fields": [],
        "type": 1
      }
    },
    "out_group": 4294967295,
    "out_port": 4294967295,
    "table_id": 255
  }
}
```

```
class ryu.ofproto.ofproto_v1_2_parser.OFPAggregateStatsReply
Aggregate flow statistics reply message
```

The switch responds with a stats reply that include this message to an aggregate flow statistics request.

Attribute	Description
packet_count	Number of packets in flows
byte_count	Number of bytes in flows
flow_count	Number of flows

Example:

```
@set_ev_cls(ofp_event.EventOFPPStatsReply, MAIN_DISPATCHER)
def stats_reply_handler(self, ev):
    msg = ev.msg
    ofp = msg.datapath.ofproto
    body = ev.msg.body

    if msg.type == ofp.OFPST_AGGREGATE:
        self.aggregate_stats_reply_handler(body)

def aggregate_stats_reply_handler(self, body):
    self.logger.debug('AggregateStats: packet_count=%d byte_count=%d '
                      'flow_count=%d',
                      body.packet_count, body.byte_count,
                      body.flow_count)
```

JSON Example:

```
{
  "OFPPStatsReply": {
    "body": {
      "OFPPAggregateStatsReply": {
        "byte_count": 574,
        "flow_count": 6,
        "packet_count": 7
      }
    },
    "flags": 0,
    "type": 2
  }
}
```

class ryu.ofproto.ofproto_v1_2_parser.OFPTableStatsRequest (datapath, flags=0)
Table statistics request message

The controller uses this message to query flow table statistics.

Attribute	Description
flags	Zero (none yet defined in the spec)

Example:

```
def send_table_stats_request(self, datapath):
    ofp_parser = datapath.ofproto_parser

    req = ofp_parser.OFPTableStatsRequest(datapath)
    datapath.send_msg(req)
```

JSON Example:

```
{
  "OFPTableStatsRequest": {
    "flags": 0
  }
}
```

```
}
}
```

class ryu.ofproto.ofproto_v1_2_parser.OFPTableStats

Table statistics reply message

The switch responds with a stats reply that include this message to a table statistics request.

Attribute	Description
table_id	ID of table
name	table name
match	Bitmap of (1 << OFPXMT_*) that indicate the fields the table can match on
wildcards	Bitmap of (1 << OFPXMT_*) wildcards that are supported by the table
write_actions	Bitmap of OFPAT_* that are supported by the table with OFPIT_WRITE_ACTIONS
apply_actions	Bitmap of OFPAT_* that are supported by the table with OFPIT_APPLY_ACTIONS
write_setfields	Bitmap of (1 << OFPXMT_*) header fields that can be set with OFPIT_WRITE_ACTIONS
apply_setfields	Bitmap of (1 << OFPXMT_*) header fields that can be set with OFPIT_APPLY_ACTIONS
meta-data_match	Bits of metadata table can match
metadata_write	Bits of metadata table can write
instructions	Bitmap of OFPIT_* values supported
config	Bitmap of OFPTC_* values
max_entries	Max number of entries supported
active_count	Number of active entries
lookup_count	Number of packets looked up in table
matched_count	Number of packets that hit table

Example:

```
@set_ev_cls(ofp_event.EventOFStatsReply, MAIN_DISPATCHER)
def stats_reply_handler(self, ev):
    msg = ev.msg
    ofp = msg.datapath.ofproto
    body = ev.msg.body

    if msg.type == ofp.OFPST_TABLE:
        self.table_stats_reply_handler(body)

def table_stats_reply_handler(self, body):
    tables = []
    for stat in body:
        tables.append('table_id=%d active_count=%d lookup_count=%d '
                    ' matched_count=%d' %
                    (stat.table_id, stat.active_count,
                     stat.lookup_count, stat.matched_count))
    self.logger.debug('TableStats: %s', tables)
```

class ryu.ofproto.ofproto_v1_2_parser.OFPPortStatsRequest (*datapath*,
port_no=4294967295,
flags=0)

Port statistics request message

The controller uses this message to query information about ports statistics.

Attribute	Description
port_no	Port number to read (OFPP_ANY to all ports)
flags	Zero (none yet defined in the spec)

Example:

```
def send_port_stats_request(self, datapath):
    ofp = datapath.ofproto
    ofp_parser = datapath.ofproto_parser

    req = ofp_parser.OFPPortStatsRequest(datapath, ofp.OFPP_ANY)
    datapath.send_msg(req)
```

JSON Example:

```
{
  "OFPPortStatsRequest": {
    "flags": 0,
    "port_no": 4294967295
  }
}
```

class ryu.ofproto.ofproto_v1_2_parser.OFPPortStats
Port statistics reply message

The switch responds with a stats reply that include this message to a port statistics request.

Attribute	Description
port_no	Port number
rx_packets	Number of received packets
tx_packets	Number of transmitted packets
rx_bytes	Number of received bytes
tx_bytes	Number of transmitted bytes
rx_dropped	Number of packets dropped by RX
tx_dropped	Number of packets dropped by TX
rx_errors	Number of receive errors
tx_errors	Number of transmit errors
rx_frame_err	Number of frame alignment errors
rx_over_err	Number of packet with RX overrun
rx_crc_err	Number of CRC errors
collisions	Number of collisions

Example:

```
@set_ev_cls(ofp_event.EventOFStatsReply, MAIN_DISPATCHER)
def stats_reply_handler(self, ev):
    msg = ev.msg
    ofp = msg.datapath.ofproto
    body = ev.msg.body

    if msg.type == ofp.OFST_PORT:
        self.port_stats_reply_handler(body)

def port_stats_reply_handler(self, body):
    ports = []
    for stat in body:
        ports.append('port_no=%d '
                    'rx_packets=%d tx_packets=%d '
                    'rx_bytes=%d tx_bytes=%d ')
```

```

        'rx_dropped=%d tx_dropped=%d '
        'rx_errors=%d tx_errors=%d '
        'rx_frame_err=%d rx_over_err=%d rx_crc_err=%d '
        'collisions=%d' %
        (stat.port_no,
         stat.rx_packets, stat.tx_packets,
         stat.rx_bytes, stat.tx_bytes,
         stat.rx_dropped, stat.tx_dropped,
         stat.rx_errors, stat.tx_errors,
         stat.rx_frame_err, stat.rx_over_err,
         stat.rx_crc_err, stat.collisions))
    self.logger.debug('PortStats: %s', ports)

```

JSON Example:

```

{
  "OFPPortStatsReply": {
    "body": [
      {
        "OFPPortStats": {
          "collisions": 0,
          "port_no": 7,
          "rx_bytes": 0,
          "rx_crc_err": 0,
          "rx_dropped": 0,
          "rx_errors": 0,
          "rx_frame_err": 0,
          "rx_over_err": 0,
          "rx_packets": 0,
          "tx_bytes": 336,
          "tx_dropped": 0,
          "tx_errors": 0,
          "tx_packets": 4
        }
      },
      {
        "OFPPortStats": {
          "collisions": 0,
          "port_no": 6,
          "rx_bytes": 336,
          "rx_crc_err": 0,
          "rx_dropped": 0,
          "rx_errors": 0,
          "rx_frame_err": 0,
          "rx_over_err": 0,
          "rx_packets": 4,
          "tx_bytes": 336,
          "tx_dropped": 0,
          "tx_errors": 0,
          "tx_packets": 4
        }
      }
    ],
    "flags": 0,
    "type": 4
  }
}

```

```
class ryu.ofproto.ofproto_v1_2_parser.OFPQueueStatsRequest (datapath,
                                                            port_no=4294967295,
                                                            queue_id=4294967295,
                                                            flags=0)
```

Queue statistics request message

The controller uses this message to query queue statistics.

Attribute	Description
port_no	Port number to read
queue_id	ID of queue to read
flags	Zero (none yet defined in the spec)

Example:

```
def send_queue_stats_request(self, datapath):
    ofp = datapath.ofproto
    ofp_parser = datapath.ofproto_parser

    req = ofp_parser.OFPQueueStatsRequest(datapath, ofp.OFPP_ANY,
                                           ofp.OFPQ_ALL)

    datapath.send_msg(req)
```

JSON Example:

```
{
  "OFPQueueStatsRequest": {
    "flags": 0,
    "port_no": 4294967295,
    "queue_id": 4294967295
  }
}
```

```
class ryu.ofproto.ofproto_v1_2_parser.OFPQueueStats
```

Queue statistics reply message

The switch responds with a stats reply that include this message to an aggregate flow statistics request.

Attribute	Description
port_no	Port number
queue_id	ID of queue
tx_bytes	Number of transmitted bytes
tx_packets	Number of transmitted packets
tx_errors	Number of packets dropped due to overrun

Example:

```
@set_ev_cls(ofp_event.EventOFPStatsReply, MAIN_DISPATCHER)
def stats_reply_handler(self, ev):
    msg = ev.msg
    ofp = msg.datapath.ofproto
    body = ev.msg.body

    if msg.type == ofp.OFPST_QUEUE:
        self.queue_stats_reply_handler(body)

def queue_stats_reply_handler(self, body):
    queues = []
    for stat in body:
        queues.append('port_no=%d queue_id=%d '
```

```

        'tx_bytes=%d tx_packets=%d tx_errors=%d ' %
        (stat.port_no, stat.queue_id,
         stat.tx_bytes, stat.tx_packets, stat.tx_errors))
    self.logger.debug('QueueStats: %s', queues)

```

JSON Example:

```

{
  "OFPPStatsReply": {
    "body": [
      {
        "OFPPQueueStats": {
          "port_no": 7,
          "queue_id": 1,
          "tx_bytes": 0,
          "tx_errors": 0,
          "tx_packets": 0
        }
      },
      {
        "OFPPQueueStats": {
          "port_no": 6,
          "queue_id": 1,
          "tx_bytes": 0,
          "tx_errors": 0,
          "tx_packets": 0
        }
      },
      {
        "OFPPQueueStats": {
          "port_no": 7,
          "queue_id": 2,
          "tx_bytes": 0,
          "tx_errors": 0,
          "tx_packets": 0
        }
      }
    ],
    "flags": 0,
    "type": 5
  }
}

```

class ryu.ofproto.ofproto_v1_2_parser.OFPPGroupStatsRequest (*datapath*,
group_id=4294967292,
flags=0)

Group statistics request message

The controller uses this message to query statistics of one or more groups.

Attribute	Description
group_id	ID of group to read (OFPG_ALL to all groups)
flags	Zero (none yet defined in the spec)

Example:

```

def send_group_stats_request(self, datapath):
    ofp = datapath.ofproto
    ofp_parser = datapath.ofproto_parser

```



```
req = ofp_parser.OFPGroupStatsRequest(datapath, ofp.OFPG_ALL)
datapath.send_msg(req)
```

class ryu.ofproto.ofproto_v1_2_parser.OFPGroupStats (group_id, ref_count, packet_count, byte_count, bucket_counters, length=None)

Group statistics reply message

The switch responds with a stats reply that include this message to a group statistics request.

Attribute	Description
group_id	Group identifier
ref_count	Number of flows or groups that directly forward to this group
packet_count	Number of packets processed by group
byte_count	Number of bytes processed by group
bucket_counters	List of OFPBucketCounter instance

Example:

```
@set_ev_cls(ofp_event.EventOFPStatsReply, MAIN_DISPATCHER)
def stats_reply_handler(self, ev):
    msg = ev.msg
    ofp = msg.datapath.ofproto
    body = ev.msg.body

    if msg.type == ofp.OFPST_GROUP:
        self.group_stats_reply_handler(body)

def group_stats_reply_handler(self, body):
    groups = []
    for stat in body:
        groups.append('group_id=%d ref_count=%d packet_count=%d '
                     'byte_count=%d bucket_counters=%s' %
                     (stat.group_id,
                      stat.ref_count, stat.packet_count,
                      stat.byte_count, stat.bucket_counters))
    self.logger.debug('GroupStats: %s', groups)
```

class ryu.ofproto.ofproto_v1_2_parser.OFPGroupDescStatsRequest (datapath, flags=0)
Group description request message

The controller uses this message to list the set of groups on a switch.

Attribute	Description
flags	Zero (none yet defined in the spec)

Example:

```
def send_group_desc_stats_request(self, datapath):
    ofp_parser = datapath.ofproto_parser

    req = ofp_parser.OFPGroupDescStatsRequest(datapath)
    datapath.send_msg(req)
```

JSON Example:

```
{
  "OFPGroupDescStatsRequest": {
    "flags": 0
  }
}
```

```
}
}
```

class ryu.ofproto.ofproto_v1_2_parser.OFPGroupDescStats (type_, group_id, buckets, length=None)

Group description reply message

The switch responds with a stats reply that include this message to a group description request.

Attribute	Description
type	One of OFPGT_*
group_id	Group identifier
buckets	List of OFPBucket instance

type attribute corresponds to type_ parameter of __init__.

Example:

```
@set_ev_cls(ofp_event.EventOFPStatsReply, MAIN_DISPATCHER)
def stats_reply_handler(self, ev):
    msg = ev.msg
    ofp = msg.datapath.ofproto
    body = ev.msg.body

    if msg.type == ofp.OFPST_GROUP_DESC:
        self.group_desc_stats_reply_handler(body)

def group_desc_stats_reply_handler(self, body):
    desc = []
    for stat in body:
        desc.append('type=%d group_id=%d buckets=%s' %
                   (stat.type, stat.group_id, stat.buckets))
    self.logger.debug('GroupDescStats: %s', desc)
```

JSON Example:

```
{
  "OFPStatsReply": {
    "body": [
      {
        "OFPGroupDescStats": {
          "buckets": [
            {
              "OFPBucket": {
                "actions": [
                  {
                    "OFPActionOutput": {
                      "len": 16,
                      "max_len": 65535,
                      "port": 2,
                      "type": 0
                    }
                  }
                ]
              }
            },
            {
              "len": 32,
              "watch_group": 1,
              "watch_port": 1,
              "weight": 1
            }
          ]
        }
      }
    ]
  }
}
```

```

        ],
        "group_id": 1,
        "length": 40,
        "type": 0
    }
}
],
"flags": 0,
"type": 7
}
}

```

class ryu.ofproto.ofproto_v1_2_parser.OFPGroupFeaturesStatsRequest (*datapath*, *flags=0*)

Group features request message

The controller uses this message to list the capabilities of groups on a switch.

Attribute	Description
flags	Zero (none yet defined in the spec)

Example:

```

def send_group_features_stats_request(self, datapath):
    ofp_parser = datapath.ofproto_parser

    req = ofp_parser.OFPGroupFeaturesStatsRequest(datapath)
    datapath.send_msg(req)

```

JSON Example:

```

{
  "OFPGroupFeaturesStatsRequest": {
    "flags": 0
  }
}

```

class ryu.ofproto.ofproto_v1_2_parser.OFPGroupFeaturesStats (*types*, *capabilities*, *max_groups*, *actions*, *length=None*)

Group features reply message

The switch responds with a stats reply that include this message to a group features request.

Attribute	Description
types	Bitmap of OFPGT_* values supported
capabilities	Bitmap of OFPGFC_* capability supported
max_groups	Maximum number of groups for each type
actions	Bitmaps of OFPAT_* that are supported

Example:

```

@set_ev_cls(ofp_event.EventOFPStatsReply, MAIN_DISPATCHER)
def stats_reply_handler(self, ev):
    msg = ev.msg
    ofp = msg.datapath.ofproto
    body = ev.msg.body

    if msg.type == ofp.OFPST_GROUP_FEATURES:
        self.group_features_stats_reply_handler(body)

```

```
def group_features_stats_reply_handler(self, body):
    self.logger.debug('GroupFeaturesStats: types=%d '
                      'capabilities=0x%08x max_groups=%s '
                      'actions=%s',
                      body.types, body.capabilities, body.max_groups,
                      body.actions)
```

JSON Example:

```
{
  "OFStatsReply": {
    "body": {
      "OFGroupFeaturesStats": {
        "actions": [
          67082241,
          67082241,
          67082241,
          67082241
        ],
        "capabilities": 5,
        "length": 40,
        "max_groups": [
          16777216,
          16777216,
          16777216,
          16777216
        ],
        "types": 15
      }
    },
    "flags": 0,
    "type": 8
  }
}
```

Queue Configuration Messages

class ryu.ofproto.ofproto_v1_2_parser.OFPQueueGetConfigRequest (datapath, port)
Queue configuration request message

Attribute	Description
port	Port to be queried (OFPP_ANY to all configured queues)

Example:

```
def send_queue_get_config_request(self, datapath):
    ofp = datapath.ofproto
    ofp_parser = datapath.ofproto_parser

    req = ofp_parser.OFPQueueGetConfigRequest(datapath, ofp.OFPP_ANY)
    datapath.send_msg(req)
```

JSON Example:

```
{
  "OFPQueueGetConfigRequest": {
    "port": 4294967295
  }
}
```

```

    }
}

```

class ryu.ofproto.ofproto_v1_2_parser.OFPQueueGetConfigReply (datapath, port=None, queues=None)

Queue configuration reply message

The switch responds with this message to a queue configuration request.

Attribute	Description
port	Port which was queried
queues	list of OFPPacketQueue instance

Example:

```

@set_ev_cls(ofp_event.EventOFPQueueGetConfigReply, MAIN_DISPATCHER)
def queue_get_config_reply_handler(self, ev):
    msg = ev.msg

    self.logger.debug('OFPQueueGetConfigReply received: '
                      'port=%s queues=%s',
                      msg.port, msg.queues)

```

JSON Example:

```

{
  "OFPQueueGetConfigReply": {
    "port": 4294967295,
    "queues": [
      {
        "OFPPacketQueue": {
          "len": 48,
          "port": 77,
          "properties": [
            {
              "OFPQueuePropMinRate": {
                "len": 16,
                "property": 1,
                "rate": 10
              }
            },
            {
              "OFPQueuePropMaxRate": {
                "len": 16,
                "property": 2,
                "rate": 900
              }
            }
          ],
          "queue_id": 99
        }
      },
      {
        "OFPPacketQueue": {
          "len": 48,
          "port": 77,
          "properties": [
            {
              "OFPQueuePropMinRate": {
                "len": 16,

```

```

        "property": 1,
        "rate": 100
    },
    {
        "OFPPQueuePropMaxRate": {
            "len": 16,
            "property": 2,
            "rate": 200
        }
    }
],
"queue_id": 88
}
}
}
}
}

```

Packet-Out Message

```

class ryu.ofproto.ofproto_v1_2_parser.OFPPacketOut (datapath,
                                                    buffer_id=None,
                                                    in_port=None,
                                                    actions=None,
                                                    data=None, actions_len=None)

```

Packet-Out message

The controller uses this message to send a packet out through the switch.

Attribute	Description
buffer_id	ID assigned by datapath (OFPP_NO_BUFFER if none)
in_port	Packet's input port or OFPP_CONTROLLER
actions	list of OpenFlow action class
data	Packet data

Example:

```

def send_packet_out(self, datapath, buffer_id, in_port):
    ofp = datapath.ofproto
    ofp_parser = datapath.ofproto_parser

    actions = [ofp_parser.OFPActionOutput(ofp.OFPP_FLOOD, 0)]
    req = ofp_parser.OFPPacketOut(datapath, buffer_id,
                                  in_port, actions)

    datapath.send_msg(req)

```

JSON Example:

```

{
  "OFPPacketOut": {
    "actions": [
      {
        "OFPActionOutput": {
          "len": 16,
          "max_len": 65535,
          "port": 4294967292,
          "type": 0
        }
      }
    ]
  }
}

```

```

    ],
    "actions_len": 16,
    "buffer_id": 4294967295,
    "data": "8guk0D9w8gukffjqCABFAABU+BoAAP8Br4sKAAABCgAAAggAAgj3YAAAMdYCAAAAAACrjS0xAAAAABARE",
    "in_port": 4294967293
  }
}

```

Barrier Message

class `ryu.ofproto.ofproto_v1_2_parser.OFPBarrierRequest` (*datapath*)

Barrier request message

The controller sends this message to ensure message dependencies have been met or receive notifications for completed operations.

Example:

```

def send_barrier_request(self, datapath):
    ofp_parser = datapath.ofproto_parser

    req = ofp_parser.OFPBarrierRequest(datapath)
    datapath.send_msg(req)

```

JSON Example:

```

{
  "OFPBarrierRequest": {}
}

```

class `ryu.ofproto.ofproto_v1_2_parser.OFPBarrierReply` (*datapath*)

Barrier reply message

The switch responds with this message to a barrier request.

Example:

```

@set_ev_cls(ofp_event.EventOFPBarrierReply, MAIN_DISPATCHER)
def barrier_reply_handler(self, ev):
    self.logger.debug('OFPBarrierReply received')

```

JSON Example:

```

{
  "OFPBarrierReply": {}
}

```

Role Request Message

class `ryu.ofproto.ofproto_v1_2_parser.OFPRoleRequest` (*datapath*, *role*, *generation_id*)

Role request message

The controller uses this message to change its role.

Attribute	Description
role	One of the following values. OFPCR_ROLE_NOCHANGE OFPCR_ROLE_EQUAL OFPCR_ROLE_MASTER OFPCR_ROLE_SLAVE
generation_id	Master Election Generation ID

Example:

```
def send_role_request(self, datapath):
    ofp = datapath.ofproto
    ofp_parser = datapath.ofproto_parser

    req = ofp_parser.OFPPRoleRequest(datapath, ofp.OFPCR_ROLE_EQUAL, 0)
    datapath.send_msg(req)
```

JSON Example:

```
{
  "OFPPRoleRequest": {
    "generation_id": 17294086455919964160,
    "role": 2
  }
}
```

class ryu.ofproto.ofproto_v1_2_parser.**OFPPRoleReply**(datapath, role=None, generation_id=None)

Role reply message

The switch responds with this message to a role request.

Attribute	Description
role	One of the following values. OFPCR_ROLE_NOCHANGE OFPCR_ROLE_EQUAL OFPCR_ROLE_MASTER OFPCR_ROLE_SLAVE
generation_id	Master Election Generation ID

Example:

```
@set_ev_cls(ofp_event.EventOFPPRoleReply, MAIN_DISPATCHER)
def role_reply_handler(self, ev):
    msg = ev.msg
    dp = msg.datapath
    ofp = dp.ofproto

    if msg.role == ofp.OFPCR_ROLE_NOCHANGE:
        role = 'NOCHANGE'
    elif msg.role == ofp.OFPCR_ROLE_EQUAL:
        role = 'EQUAL'
    elif msg.role == ofp.OFPCR_ROLE_MASTER:
        role = 'MASTER'
    elif msg.role == ofp.OFPCR_ROLE_SLAVE:
```



```

        role = 'SLAVE'
    else:
        role = 'unknown'

    self.logger.debug('OFPRoleReply received: '
                      'role=%s generation_id=%d',
                      role, msg.generation_id)

```

JSON Example:

```

{
  "OFPRoleReply": {
    "generation_id": 17294086455919964160,
    "role": 3
  }
}

```

Asynchronous Messages

Packet-In Message

```

class ryu.ofproto.ofproto_v1_2_parser.OFPPacketIn(datapath,
                                                    buffer_id=None,
                                                    total_len=None,
                                                    reason=None,
                                                    table_id=None,
                                                    match=None,
                                                    data=None)

```

Packet-In message

The switch sends the packet that received to the controller by this message.

Attribute	Description
buffer_id	ID assigned by datapath
total_len	Full length of frame
reason	Reason packet is being sent. OFPR_NO_MATCH OFPR_ACTION OFPR_INVALID_TTL
table_id	ID of the table that was looked up
match	Instance of OFPMatch
data	Ethernet frame

Example:

```

@set_ev_cls(ofp_event.EventOFPPacketIn, MAIN_DISPATCHER)
def packet_in_handler(self, ev):
    msg = ev.msg
    dp = msg.datapath
    ofp = dp.ofproto

    if msg.reason == ofp.OFPR_NO_MATCH:
        reason = 'NO MATCH'
    elif msg.reason == ofp.OFPR_ACTION:
        reason = 'ACTION'
    elif msg.reason == ofp.OFPR_INVALID_TTL:
        reason = 'INVALID TTL'

```

```

else:
    reason = 'unknown'

self.logger.debug('OFPPacketIn received: '
                  'buffer_id=%x total_len=%d reason=%s '
                  'table_id=%d match=%s data=%s',
                  msg.buffer_id, msg.total_len, reason,
                  msg.table_id, msg.match,
                  utils.hex_array(msg.data))

```

JSON Example:

```

{
  "OFPPacketIn": {
    "buffer_id": 2,
    "data": "/////////8gukffjqCAYAAQgABgQAAfILpH346goAAAEAAAAAAAAAKAAAD",
    "match": {
      "OFPMatch": {
        "length": 80,
        "oxm_fields": [
          {
            "OXMTlv": {
              "field": "in_port",
              "mask": null,
              "value": 6
            }
          },
          {
            "OXMTlv": {
              "field": "eth_type",
              "mask": null,
              "value": 2054
            }
          },
          {
            "OXMTlv": {
              "field": "eth_dst",
              "mask": null,
              "value": "ff:ff:ff:ff:ff:ff"
            }
          },
          {
            "OXMTlv": {
              "field": "eth_src",
              "mask": null,
              "value": "f2:0b:a4:7d:f8:ea"
            }
          },
          {
            "OXMTlv": {
              "field": "arp_op",
              "mask": null,
              "value": 1
            }
          },
          {
            "OXMTlv": {
              "field": "arp_spa",

```

```

        "mask": null,
        "value": "10.0.0.1"
    }
},
{
    "OXMTlv": {
        "field": "arp_tpa",
        "mask": null,
        "value": "10.0.0.3"
    }
},
{
    "OXMTlv": {
        "field": "arp_sha",
        "mask": null,
        "value": "f2:0b:a4:7d:f8:ea"
    }
},
{
    "OXMTlv": {
        "field": "arp_tha",
        "mask": null,
        "value": "00:00:00:00:00:00"
    }
}
],
"type": 1
}
},
"reason": 1,
"table_id": 1,
"total_len": 42
}
}

```

Flow Removed Message

```

class ryu.ofproto.ofproto_v1_2_parser.OFPFlowRemoved(datapath, cookie=None, priority=None, reason=None, table_id=None, duration_sec=None, duration_nsec=None, idle_timeout=None, hard_timeout=None, packet_count=None, byte_count=None, match=None)

```

Flow removed message

When flow entries time out or are deleted, the switch notifies controller with this message.

Attribute	Description
cookie	Opaque controller-issued identifier
priority	Priority level of flow entry
reason	One of the following values. OFPRR_IDLE_TIMEOUT OFPRR_HARD_TIMEOUT OFPRR_DELETE OFPRR_GROUP_DELETE
table_id	ID of the table
duration_sec	Time flow was alive in seconds
duration_nsec	Time flow was alive in nanoseconds beyond duration_sec
idle_timeout	Idle timeout from original flow mod
hard_timeout	Hard timeout from original flow mod
packet_count	Number of packets that was associated with the flow
byte_count	Number of bytes that was associated with the flow
match	Instance of OFPMatch

Example:

```
@set_ev_cls(ofp_event.EventOFPPFlowRemoved, MAIN_DISPATCHER)
def flow_removed_handler(self, ev):
    msg = ev.msg
    dp = msg.datapath
    ofp = dp.ofproto

    if msg.reason == ofp.OFPRR_IDLE_TIMEOUT:
        reason = 'IDLE TIMEOUT'
    elif msg.reason == ofp.OFPRR_HARD_TIMEOUT:
        reason = 'HARD TIMEOUT'
    elif msg.reason == ofp.OFPRR_DELETE:
        reason = 'DELETE'
    elif msg.reason == ofp.OFPRR_GROUP_DELETE:
        reason = 'GROUP DELETE'
    else:
        reason = 'unknown'

    self.logger.debug('OFPPFlowRemoved received: '
                      'cookie=%d priority=%d reason=%s table_id=%d '
                      'duration_sec=%d duration_nsec=%d '
                      'idle_timeout=%d hard_timeout=%d '
                      'packet_count=%d byte_count=%d match.fields=%s',
                      msg.cookie, msg.priority, reason, msg.table_id,
                      msg.duration_sec, msg.duration_nsec,
                      msg.idle_timeout, msg.hard_timeout,
                      msg.packet_count, msg.byte_count, msg.match)
```

JSON Example:

```
{
  "OFPPFlowRemoved": {
    "byte_count": 86,
    "cookie": 0,
    "duration_nsec": 48825000,
    "duration_sec": 3,
```

```

    "hard_timeout": 0,
    "idle_timeout": 3,
    "match": {
        "OFPMatch": {
            "length": 14,
            "oxm_fields": [
                {
                    "OXMTlv": {
                        "field": "eth_dst",
                        "mask": null,
                        "value": "f2:0b:a4:7d:f8:ea"
                    }
                }
            ],
            "type": 1
        }
    },
    "packet_count": 1,
    "priority": 65535,
    "reason": 0,
    "table_id": 0
}
}

```

Port Status Message

class ryu.ofproto.ofproto_v1_2_parser.**OFPPortStatus** (*datapath*, *reason=None*, *desc=None*)

Port status message

The switch notifies controller of change of ports.

Attribute	Description
reason	One of the following values. OFPPR_ADD OFPPR_DELETE OFPPR_MODIFY
desc	instance of OFPPort

Example:

```

@set_ev_cls(ofp_event.EventOFPPortStatus, MAIN_DISPATCHER)
def port_status_handler(self, ev):
    msg = ev.msg
    dp = msg.datapath
    ofp = dp.ofproto

    if msg.reason == ofp.OFPPR_ADD:
        reason = 'ADD'
    elif msg.reason == ofp.OFPPR_DELETE:
        reason = 'DELETE'
    elif msg.reason == ofp.OFPPR_MODIFY:
        reason = 'MODIFY'
    else:
        reason = 'unknown'

```

```
self.logger.debug('OFPPortStatus received: reason=%s desc=%s',
                  reason, msg.desc)
```

JSON Example:

```
{
  "OFPPortStatus": {
    "desc": {
      "OFPPort": {
        "advertised": 10240,
        "config": 0,
        "curr": 10248,
        "curr_speed": 5000,
        "hw_addr": "f2:0b:a4:d0:3f:70",
        "max_speed": 5000,
        "name": "\u79c1\u306e\u30dd\u30fc\u30c8",
        "peer": 10248,
        "port_no": 7,
        "state": 4,
        "supported": 10248
      }
    },
    "reason": 0
  }
}
```

Error Message

`class ryu.ofproto.ofproto_v1_2_parser.OFPErrormsg(datapath, type=None, code=None, data=None)`

Error message

The switch notifies controller of problems by this message.

Attribute	Description
type	High level type of error
code	Details depending on the type
data	Variable length data depending on the type and code

type attribute corresponds to type_ parameter of `__init__`.

Types and codes are defined in `ryu.ofproto.ofproto`.

Type	Code
OFPET_HELLO_FAILED	OFPHFC_*
OFPET_BAD_REQUEST	OFPBRC_*
OFPET_BAD_ACTION	OFPBAC_*
OFPET_BAD_INSTRUCTION	OFPBIC_*
OFPET_BAD_MATCH	OFPBMC_*
OFPET_FLOW_MOD_FAILED	OFPFMFC_*
OFPET_GROUP_MOD_FAILED	OFPGMFC_*
OFPET_PORT_MOD_FAILED	OFPPMFC_*
OFPET_TABLE_MOD_FAILED	OFPTMFC_*
OFPET_QUEUE_OP_FAILED	OFPQOFC_*
OFPET_SWITCH_CONFIG_FAILED	OFPSCFC_*
OFPET_ROLE_REQUEST_FAILED	OFPRRFC_*
OFPET_EXPERIMENTER	N/A

Example:

```
@set_ev_cls(ofp_event.EventOFPErrormsg,
            [HANDSHAKE_DISPATCHER, CONFIG_DISPATCHER, MAIN_DISPATCHER])
def error_msg_handler(self, ev):
    msg = ev.msg

    self.logger.debug('OFPErrormsg received: type=0x%02x code=0x%02x '
                      'message=%s',
                      msg.type, msg.code, utils.hex_array(msg.data))
```

JSON Example:

```
{
  "OFPErrormsg": {
    "code": 11,
    "data": "ZnVnYWZ1Z2E=",
    "type": 2
  }
}
```

```
{
  "OFPErrormsg": {
    "data": "amlra2VuIGRhdGE=",
    "exp_type": 60000,
    "experimenter": 999999,
    "type": 65535
  }
}
```

Symmetric Messages

Hello

class ryu.ofproto.ofproto_v1_2_parser.**OFPHello** (*datapath*)
Hello message

When connection is started, the hello message is exchanged between a switch and a controller.

This message is handled by the Ryu framework, so the Ryu application do not need to process this typically.

JSON Example:

```
{
  "OFPHello": {}
}
```

Echo Request

class ryu.ofproto.ofproto_v1_2_parser.**OFPEchoRequest** (*datapath*, *data=None*)
Echo request message

This message is handled by the Ryu framework, so the Ryu application do not need to process this typically.

Attribute	Description
data	An arbitrary length data

Example:

```

def send_echo_request(self, datapath, data):
    ofp_parser = datapath.ofproto_parser

    req = ofp_parser.OFPEchoRequest(datapath, data)
    datapath.send_msg(req)

    @set_ev_cls(ofp_event.EventOFPEchoRequest,
                [HANDSHAKE_DISPATCHER, CONFIG_DISPATCHER, MAIN_DISPATCHER])
    def echo_request_handler(self, ev):
        self.logger.debug('OFPEchoRequest received: data=%s',
                          utils.hex_array(ev.msg.data))

```

JSON Example:

```

{
  "OFPEchoRequest": {
    "data": "aG9nZQ=="
  }
}

```

Echo Reply

class ryu.ofproto.ofproto_v1_2_parser.OFPEchoReply(*datapath*, *data=None*)

Echo reply message

This message is handled by the Ryu framework, so the Ryu application do not need to process this typically.

Attribute	Description
data	An arbitrary length data

Example:

```

def send_echo_reply(self, datapath, data):
    ofp_parser = datapath.ofproto_parser

    reply = ofp_parser.OFPEchoReply(datapath, data)
    datapath.send_msg(reply)

    @set_ev_cls(ofp_event.EventOFPEchoReply,
                [HANDSHAKE_DISPATCHER, CONFIG_DISPATCHER, MAIN_DISPATCHER])
    def echo_reply_handler(self, ev):
        self.logger.debug('OFPEchoReply received: data=%s',
                          utils.hex_array(ev.msg.data))

```

JSON Example:

```

{
  "OFPEchoReply": {
    "data": "aG9nZQ=="
  }
}

```

Experimenter

class ryu.ofproto.ofproto_v1_2_parser.OFPExperimenter(*datapath*, *experimenter=None*,
exp_type=None, *data=None*)

Experimenter extension message

Attribute	Description
experimenter	Experimenter ID
exp_type	Experimenter defined
data	Experimenter defined arbitrary additional data

JSON Example:

```

{
  "OFPExperimenter": {
    "data": "bmF6bw==",
    "exp_type": 123456789,
    "experimenter": 98765432
  }
}

```

Port Structures

class ryu.ofproto.ofproto_v1_2_parser.OFPPort

Description of a port

Attribute	Description
port_no	Port number and it uniquely identifies a port within a switch.
hw_addr	MAC address for the port.
name	Null-terminated string containing a human-readable name for the interface.
config	Bitmap of port configuration flags. OFPPC_PORT_DOWN OFPPC_NO_RECV OFPPC_NO_FWD OFPPC_NO_PACKET_IN
state	Bitmap of port state flags. OFPPS_LINK_DOWN OFPPS_BLOCKED OFPPS_LIVE
curr	Current features.
advertised	Features being advertised by the port.
supported	Features supported by the port.
peer	Features advertised by peer.
curr_speed	Current port bitrate in kbps.
max_speed	Max port bitrate in kbps.

Flow Match Structure

class ryu.ofproto.ofproto_v1_2_parser.OFPMatch (*type_=None, length=None, _ordered_fields=None, **kwargs*)

Flow Match Structure

This class is implementation of the flow match structure having compose/query API. There are new API and old API for compatibility. the old API is supposed to be removed later.

You can define the flow match by the keyword arguments. The following arguments are available.

Argument	Value	Description
in_port	Integer 32bit	Switch input port
in_phy_port	Integer 32bit	Switch physical input port
metadata	Integer 64bit	Metadata passed between tables
eth_dst	MAC address	Ethernet destination address
eth_src	MAC address	Ethernet source address
eth_type	Integer 16bit	Ethernet frame type
vlan_vid	Integer 16bit	VLAN id
vlan_pcp	Integer 8bit	VLAN priority
ip_dscp	Integer 8bit	IP DSCP (6 bits in ToS field)
ip_ecn	Integer 8bit	IP ECN (2 bits in ToS field)
ip_proto	Integer 8bit	IP protocol
ipv4_src	IPv4 address	IPv4 source address
ipv4_dst	IPv4 address	IPv4 destination address
tcp_src	Integer 16bit	TCP source port
tcp_dst	Integer 16bit	TCP destination port
udp_src	Integer 16bit	UDP source port
udp_dst	Integer 16bit	UDP destination port
sctp_src	Integer 16bit	SCTP source port
sctp_dst	Integer 16bit	SCTP destination port
icmpv4_type	Integer 8bit	ICMP type
icmpv4_code	Integer 8bit	ICMP code
arp_op	Integer 16bit	ARP opcode
arp_spa	IPv4 address	ARP source IPv4 address
arp_tpa	IPv4 address	ARP target IPv4 address
arp_sha	MAC address	ARP source hardware address
arp_tha	MAC address	ARP target hardware address
ipv6_src	IPv6 address	IPv6 source address
ipv6_dst	IPv6 address	IPv6 destination address
ipv6_flabel	Integer 32bit	IPv6 Flow Label
icmpv6_type	Integer 8bit	ICMPv6 type
icmpv6_code	Integer 8bit	ICMPv6 code
ipv6_nd_target	IPv6 address	Target address for ND
ipv6_nd_sll	MAC address	Source link-layer for ND
ipv6_nd_tll	MAC address	Target link-layer for ND
mpls_label	Integer 32bit	MPLS label
mpls_tc	Integer 8bit	MPLS TC
pbb_uca	Integer 8bit	PBB UCA header field (EXT-256 Old version of ONF Extension)
tcp_flags	Integer 16bit	TCP flags (EXT-109 ONF Extension)
actset_output	Integer 32bit	Output port from action set metadata (EXT-233 ONF Extension)

Example:

```
>>> # compose
>>> match = parser.OFPMatch(
...     in_port=1,
...     eth_type=0x86dd,
...     ipv6_src=('2001:db8:bd05:1d2:288a:1fc0:1:10ee',
...              'ffff:ffff:ffff:ffff::'),
...     ipv6_dst='2001:db8:bd05:1d2:288a:1fc0:1:10ee')
>>> # query
```

```
>>> if 'ipv6_src' in match:
...     print match['ipv6_src']
...
('2001:db8:bd05:1d2:288a:1fc0:1:10ee', 'ffff:ffff:ffff:ffff::')
```

Note: For the list of the supported Nicira experimenter matches, please refer to [ryu.ofproto.nx_match](#).

Note: For VLAN id match field, special values are defined in OpenFlow Spec.

1. Packets with and without a VLAN tag

•Example:

```
match = parser.OFPMatch()
```

•Packet Matching

non-VLAN-tagged	MATCH
VLAN-tagged(vlan_id=3)	MATCH
VLAN-tagged(vlan_id=5)	MATCH

2. Only packets without a VLAN tag

•Example:

```
match = parser.OFPMatch(vlan_vid=0x0000)
```

•Packet Matching

non-VLAN-tagged	MATCH
VLAN-tagged(vlan_id=3)	x
VLAN-tagged(vlan_id=5)	x

3. Only packets with a VLAN tag regardless of its value

•Example:

```
match = parser.OFPMatch(vlan_vid=(0x1000, 0x1000))
```

•Packet Matching

non-VLAN-tagged	x
VLAN-tagged(vlan_id=3)	MATCH
VLAN-tagged(vlan_id=5)	MATCH

4. Only packets with VLAN tag and VID equal

•Example:

```
match = parser.OFPMatch(vlan_vid=(0x1000 | 3))
```

•Packet Matching

non-VLAN-tagged	x
VLAN-tagged(vlan_id=3)	MATCH
VLAN-tagged(vlan_id=5)	x

Flow Instruction Structures

class ryu.ofproto.ofproto_v1_2_parser.**OFFInstructionGotoTable** (*table_id*,
type_=None,
len_=None)

Goto table instruction

This instruction indicates the next table in the processing pipeline.

Attribute	Description
table_id	Next table

class ryu.ofproto.ofproto_v1_2_parser.**OFFInstructionWriteMetadata** (*metadata*,
meta-
data_mask,
type_=None,
len_=None)

Write metadata instruction

This instruction writes the masked metadata value into the metadata field.

Attribute	Description
metadata	Metadata value to write
metadata_mask	Metadata write bitmask

class ryu.ofproto.ofproto_v1_2_parser.**OFFInstructionActions** (*type_*, *actions=None*,
len_=None)

Actions instruction

This instruction writes/applies/clears the actions.

Attribute	Description
type	One of following values. OFFPIT_WRITE_ACTIONS OFFPIT_APPLY_ACTIONS OFFPIT_CLEAR_ACTIONS
actions	list of OpenFlow action class

type attribute corresponds to type_ parameter of __init__.

Action Structures

class ryu.ofproto.ofproto_v1_2_parser.**OFFActionOutput** (*port*, *max_len=65509*,
type_=None, len_=None)

Output action

This action indicates output a packet to the switch port.

Attribute	Description
port	Output port
max_len	Max length to send to controller

class ryu.ofproto.ofproto_v1_2_parser.**OFFActionGroup** (*group_id=0*, *type_=None*,
len_=None)

Group action

This action indicates the group used to process the packet.

Attribute	Description
group_id	Group identifier

class ryu.ofproto.ofproto_v1_2_parser.**OFFActionSetQueue** (*queue_id*, *type_=None*, *len_=None*)

Set queue action

This action sets the queue id that will be used to map a flow to an already-configured queue on a port.

Attribute	Description
queue_id	Queue ID for the packets

class ryu.ofproto.ofproto_v1_2_parser.**OFFActionSetMplsTtl** (*mpls_ttl*, *type_=None*, *len_=None*)

Set MPLS TTL action

This action sets the MPLS TTL.

Attribute	Description
mpls_ttl	MPLS TTL

class ryu.ofproto.ofproto_v1_2_parser.**OFFActionDecMplsTtl** (*type_=None*, *len_=None*)

Decrement MPLS TTL action

This action decrements the MPLS TTL.

class ryu.ofproto.ofproto_v1_2_parser.**OFFActionSetNwTtl** (*nw_ttl*, *type_=None*, *len_=None*)

Set IP TTL action

This action sets the IP TTL.

Attribute	Description
nw_ttl	IP TTL

class ryu.ofproto.ofproto_v1_2_parser.**OFFActionDecNwTtl** (*type_=None*, *len_=None*)

Decrement IP TTL action

This action decrements the IP TTL.

class ryu.ofproto.ofproto_v1_2_parser.**OFFActionCopyTtlOut** (*type_=None*, *len_=None*)

Copy TTL Out action

This action copies the TTL from the next-to-outermost header with TTL to the outermost header with TTL.

class ryu.ofproto.ofproto_v1_2_parser.**OFFActionCopyTtlIn** (*type_=None*, *len_=None*)

Copy TTL In action

This action copies the TTL from the outermost header with TTL to the next-to-outermost header with TTL.

class ryu.ofproto.ofproto_v1_2_parser.**OFFActionPushVlan** (*ethertype=33024*, *type_=None*, *len_=None*)

Push VLAN action

This action pushes a new VLAN tag to the packet.

Attribute	Description
ethertype	Ether type. The default is 802.1Q. (0x8100)

class ryu.ofproto.ofproto_v1_2_parser.**OFFActionPushMpls** (*ethertype=34887*, *type_=None*, *len_=None*)

Push MPLS action

This action pushes a new MPLS header to the packet.

Attribute	Description
ethertype	Ether type

class ryu.ofproto.ofproto_v1_2_parser.**OFFActionPopVlan** (*type_=None, len_=None*)
Pop VLAN action

This action pops the outermost VLAN tag from the packet.

class ryu.ofproto.ofproto_v1_2_parser.**OFFActionPopMpls** (*ethertype=2048, type_=None, len_=None*)
Pop MPLS action

This action pops the MPLS header from the packet.

class ryu.ofproto.ofproto_v1_2_parser.**OFFActionSetField** (*field=None, **kwargs*)
Set field action

This action modifies a header field in the packet.

The set of keywords available for this is same as OFFPMatch.

Example:

```
set_field = OFFActionSetField(eth_src="00:00:00:00:00:00")
```

class ryu.ofproto.ofproto_v1_2_parser.**OFFActionExperimenter** (*experimenter, type_=None, len_=None*)
Experimenter action

This action is an extensible action for the experimenter.

Attribute	Description
experimenter	Experimenter ID

Note: For the list of the supported Nicira experimenter actions, please refer to [ryu.ofproto.nx_actions](#).

2.5.4 OpenFlow v1.3 Messages and Structures

Controller-to-Switch Messages

Handshake

class ryu.ofproto.ofproto_v1_3_parser.**OFFFeaturesRequest** (*datapath*)
Features request message

The controller sends a feature request to the switch upon session establishment.

This message is handled by the Ryu framework, so the Ryu application do not need to process this typically.

Example:

```
def send_features_request(self, datapath):
    ofp_parser = datapath.ofproto_parser

    req = ofp_parser.OFFFeaturesRequest(datapath)
    datapath.send_msg(req)
```

JSON Example:

```
{
  "OFFFeaturesRequest": {}
}
```

```
class ryu.ofproto.ofproto_v1_3_parser.OFPSwitchFeatures (datapath, datapath_id=None,
                                                         n_buffers=None,
                                                         n_tables=None,      auxil-
                                                         iary_id=None,      capabili-
                                                         ties=None)
```

Features reply message

The switch responds with a features reply message to a features request.

This message is handled by the Ryu framework, so the Ryu application do not need to process this typically.

Example:

```
@set_ev_cls(ofp_event.EventOFPSwitchFeatures, CONFIG_DISPATCHER)
def switch_features_handler(self, ev):
    msg = ev.msg

    self.logger.debug('OFPSwitchFeatures received: '
                      'datapath_id=0x%016x n_buffers=%d '
                      'n_tables=%d auxiliary_id=%d '
                      'capabilities=0x%08x',
                      msg.datapath_id, msg.n_buffers, msg.n_tables,
                      msg.auxiliary_id, msg.capabilities)
```

JSON Example:

```
{
  "OFPSwitchFeatures": {
    "auxiliary_id": 99,
    "capabilities": 79,
    "datapath_id": 9210263729383,
    "n_buffers": 0,
    "n_tables": 255
  }
}
```

Switch Configuration

```
class ryu.ofproto.ofproto_v1_3_parser.OFPSetConfig (datapath, flags=0, miss_send_len=0)
Set config request message
```

The controller sends a set config request message to set configuraion parameters.

Attribute	Description
flags	Bitmap of the following flags. OFPC_FRAG_NORMAL OFPC_FRAG_DROP OFPC_FRAG_REASM
miss_send_len	Max bytes of new flow that datapath should send to the controller

Example:

```
def send_set_config(self, datapath):
    ofp = datapath.ofproto
    ofp_parser = datapath.ofproto_parser
```

```
req = ofp_parser.OFPSetConfig(datapath, ofp.OFPC_FRAG_NORMAL, 256)
datapath.send_msg(req)
```

JSON Example:

```
{
  "OFPSetConfig": {
    "flags": 0,
    "miss_send_len": 128
  }
}
```

class `ryu.ofproto.ofproto_v1_3_parser.OFPGetConfigRequest` (*datapath*)
Get config request message

The controller sends a get config request to query configuration parameters in the switch.

Example:

```
def send_get_config_request(self, datapath):
    ofp_parser = datapath.ofproto_parser

    req = ofp_parser.OFPGetConfigRequest(datapath)
    datapath.send_msg(req)
```

JSON Example:

```
{
  "OFPGetConfigRequest": {}
}
```

class `ryu.ofproto.ofproto_v1_3_parser.OFPGetConfigReply` (*datapath*, *flags=None*, *miss_send_len=None*)
Get config reply message

The switch responds to a configuration request with a get config reply message.

Attribute	Description
flags	Bitmap of the following flags. OFPC_FRAG_NORMAL OFPC_FRAG_DROP OFPC_FRAG_REASM OFPC_FRAG_MASK
miss_send_len	Max bytes of new flow that datapath should send to the controller

Example:

```
@set_ev_cls(ofp_event.EventOFPGetConfigReply, MAIN_DISPATCHER)
def get_config_reply_handler(self, ev):
    msg = ev.msg
    dp = msg.datapath
    ofp = dp.ofproto
    flags = []

    if msg.flags & ofp.OFPC_FRAG_NORMAL:
        flags.append('NORMAL')
    if msg.flags & ofp.OFPC_FRAG_DROP:
```



```

        flags.append('DROP')
    if msg.flags & ofp.OFPC_FRAG_REASM:
        flags.append('REASM')
    self.logger.debug('OFPPGetConfigReply received: '
                      'flags=%s miss_send_len=%d',
                      ','.join(flags), msg.miss_send_len)

```

JSON Example:

```

{
  "OFPPGetConfigReply": {
    "flags": 0,
    "miss_send_len": 128
  }
}

```

Flow Table Configuration

class ryu.ofproto.ofproto_v1_3_parser.**OFPTTableMod**(datapath, table_id, config)
Flow table configuration message

The controller sends this message to configure table state.

Attribute	Description
table_id	ID of the table (OFPTT_ALL indicates all tables)
config	Bitmap of the following flags. OFPTC_DEPRECATED_MASK (3)

Example:

```

def send_table_mod(self, datapath):
    ofp_parser = datapath.ofproto_parser

    req = ofp_parser.OFPTTableMod(datapath, 1, 3)
    datapath.send_msg(req)

```

JSON Example:

```

{
  "OFPTTableMod": {
    "config": 0,
    "table_id": 255
  }
}

```

Modify State Messages

class ryu.ofproto.ofproto_v1_3_parser.**OFPFLOWMod**(datapath, cookie=0, cookie_mask=0, table_id=0, command=0, idle_timeout=0, hard_timeout=0, priority=32768, buffer_id=4294967295, out_port=0, out_group=0, flags=0, match=None, instructions=None)
Modify Flow entry message

Modify Flow entry message

The controller sends this message to modify the flow table.

Attribute	Description
cookie	Opaque controller-issued identifier
cookie_mask	Mask used to restrict the cookie bits that must match when the command is OFPFC_MODIFY* or OFPFC_DELETE*
table_id	ID of the table to put the flow in
command	One of the following values. OFPFC_ADD OFPFC_MODIFY OFPFC_MODIFY_STRICT OFPFC_DELETE OFPFC_DELETE_STRICT
idle_timeout	Idle time before discarding (seconds)
hard_timeout	Max time before discarding (seconds)
priority	Priority level of flow entry
buffer_id	Buffered packet to apply to (or OFP_NO_BUFFER)
out_port	For OFPFC_DELETE* commands, require matching entries to include this as an output port
out_group	For OFPFC_DELETE* commands, require matching entries to include this as an output group
flags	Bitmap of the following flags. OFPFF_SEND_FLOW_REM OFPFF_CHECK_OVERLAP OFPFF_RESET_COUNTS OFPFF_NO_PKT_COUNTS OFPFF_NO_BYT_COUNTS
match	Instance of OFPMatch
instructions	list of OFPInstruction* instance

Example:

```
def send_flow_mod(self, datapath):
    ofp = datapath.ofproto
    ofp_parser = datapath.ofproto_parser

    cookie = cookie_mask = 0
    table_id = 0
    idle_timeout = hard_timeout = 0
    priority = 32768
    buffer_id = ofp.OFP_NO_BUFFER
    match = ofp_parser.OFPMatch(in_port=1, eth_dst='ff:ff:ff:ff:ff:ff')
    actions = [ofp_parser.OFPActionOutput(ofp.OFPP_NORMAL, 0)]
    inst = [ofp_parser.OFPInstructionActions(ofp.OFPIT_APPLY_ACTIONS,
                                             actions)]
    req = ofp_parser.OFPFlowMod(datapath, cookie, cookie_mask,
                                table_id, ofp.OFPFC_ADD,
                                idle_timeout, hard_timeout,
                                priority, buffer_id,
                                ofp.OFPP_ANY, ofp.OFPG_ANY,
                                ofp.OFPFF_SEND_FLOW_REM,
                                match, inst)
```

```
datapath.send_msg(req)
```

JSON Example:

```
{
  "OFPPFlowMod": {
    "buffer_id": 65535,
    "command": 0,
    "cookie": 0,
    "cookie_mask": 0,
    "flags": 0,
    "hard_timeout": 0,
    "idle_timeout": 0,
    "instructions": [
      {
        "OFPIInstructionActions": {
          "actions": [
            {
              "OFPActionSetField": {
                "field": {
                  "OXMTlv": {
                    "field": "vlan_vid",
                    "mask": null,
                    "value": 258
                  }
                }
              },
              "len": 16,
              "type": 25
            },
            {
              "OFPActionCopyTtlOut": {
                "len": 8,
                "type": 11
              }
            },
            {
              "OFPActionCopyTtlIn": {
                "len": 8,
                "type": 12
              }
            },
            {
              "OFPActionCopyTtlIn": {
                "len": 8,
                "type": 12
              }
            },
            {
              "OFPActionPopPbb": {
                "len": 8,
                "type": 27
              }
            },
            {
              "OFPActionPushPbb": {
                "ethertype": 4660,
                "len": 8,

```

```
        "type": 26
    },
    {
        "OFPActionPopMpls": {
            "ethertype": 39030,
            "len": 8,
            "type": 20
        }
    },
    {
        "OFPActionPushMpls": {
            "ethertype": 34887,
            "len": 8,
            "type": 19
        }
    },
    {
        "OFPActionPopVlan": {
            "len": 8,
            "type": 18
        }
    },
    {
        "OFPActionPushVlan": {
            "ethertype": 33024,
            "len": 8,
            "type": 17
        }
    },
    {
        "OFPActionDecMplsTtl": {
            "len": 8,
            "type": 16
        }
    },
    {
        "OFPActionSetMplsTtl": {
            "len": 8,
            "mpls_ttl": 10,
            "type": 15
        }
    },
    {
        "OFPActionDecNwTtl": {
            "len": 8,
            "type": 24
        }
    },
    {
        "OFPActionSetNwTtl": {
            "len": 8,
            "nw_ttl": 10,
            "type": 23
        }
    },
    {
        "OFPActionExperimenterUnknown": {
```

```

        "data": "AAECAwQFBgc=",
        "experimenter": 101,
        "len": 16,
        "type": 65535
    },
    {
        "OFPActionSetQueue": {
            "len": 8,
            "queue_id": 3,
            "type": 21
        }
    },
    {
        "OFPActionGroup": {
            "group_id": 99,
            "len": 8,
            "type": 22
        }
    },
    {
        "OFPActionOutput": {
            "len": 16,
            "max_len": 65535,
            "port": 6,
            "type": 0
        }
    }
],
"len": 176,
"type": 3
},
{
    "OFPIInstructionActions": {
        "actions": [
            {
                "OFPActionSetField": {
                    "field": {
                        "OXMTlv": {
                            "field": "eth_src",
                            "mask": null,
                            "value": "01:02:03:04:05:06"
                        }
                    }
                },
                "len": 16,
                "type": 25
            }
        ],
        "OFPActionSetField": {
            "field": {
                "OXMTlv": {
                    "field": "pbb_uca",
                    "mask": null,
                    "value": 1
                }
            }
        }
    }
},

```

```

        "len": 16,
        "type": 25
    }
    },
    ],
    "len": 40,
    "type": 4
}
},
],
"match": {
  "OFPMatch": {
    "length": 14,
    "oxm_fields": [
      {
        "OXMTlv": {
          "field": "eth_dst",
          "mask": null,
          "value": "f2:0b:a4:7d:f8:ea"
        }
      }
    ],
    "type": 1
  }
},
"out_group": 4294967295,
"out_port": 4294967295,
"priority": 123,
"table_id": 1
}
}
}

```

```

{
  "OFPPFlowMod": {
    "buffer_id": 65535,
    "command": 0,
    "cookie": 0,
    "cookie_mask": 0,
    "flags": 0,
    "hard_timeout": 0,
    "idle_timeout": 0,
    "instructions": [
      {
        "OFPIInstructionGotoTable": {
          "len": 8,
          "table_id": 1,
          "type": 1
        }
      }
    ],
    "match": {
      "OFPMatch": {
        "length": 22,
        "oxm_fields": [
          {
            "OXMTlv": {
              "field": "in_port",
              "mask": null,

```

```

        "value": 6
      }
    },
    {
      "OXMTlv": {
        "field": "eth_src",
        "mask": null,
        "value": "f2:0b:a4:7d:f8:ea"
      }
    }
  ],
  "type": 1
}
},
"out_group": 4294967295,
"out_port": 4294967295,
"priority": 123,
"table_id": 0
}
}

```

```

{
  "OFPPFlowMod": {
    "buffer_id": 65535,
    "command": 0,
    "cookie": 0,
    "cookie_mask": 0,
    "flags": 0,
    "hard_timeout": 0,
    "idle_timeout": 0,
    "instructions": [
      {
        "OFPIInstructionMeter": {
          "len": 8,
          "meter_id": 1,
          "type": 6
        }
      },
      {
        "OFPIInstructionActions": {
          "actions": [
            {
              "OFPAActionOutput": {
                "len": 16,
                "max_len": 65535,
                "port": 6,
                "type": 0
              }
            }
          ],
          "len": 24,
          "type": 3
        }
      }
    ],
    "match": {
      "OFPMatch": {
        "length": 14,

```

```

        "oxm_fields": [
            {
                "OXMTlv": {
                    "field": "eth_dst",
                    "mask": null,
                    "value": "f2:0b:a4:7d:f8:ea"
                }
            }
        ],
        "type": 1
    }
},
"out_group": 4294967295,
"out_port": 4294967295,
"priority": 123,
"table_id": 1
}
}

```

class ryu.ofproto.ofproto_v1_3_parser.OFPGroupMod(*datapath*, *command=0*, *type_=0*, *group_id=0*, *buckets=None*)

Modify group entry message

The controller sends this message to modify the group table.

Attribute	Description
command	One of the following values. OFPGC_ADD OFPGC_MODIFY OFPGC_DELETE
type	One of the following values. OFPGT_ALL OFPGT_SELECT OFPGT_INDIRECT OFPGT_FF
group_id	Group identifier
buckets	list of OFPBucket

type attribute corresponds to type_ parameter of __init__.

Example:

```

def send_group_mod(self, datapath):
    ofp = datapath.ofproto
    ofp_parser = datapath.ofproto_parser

    port = 1
    max_len = 2000
    actions = [ofp_parser.OFPActionOutput(port, max_len)]

    weight = 100
    watch_port = 0
    watch_group = 0
    buckets = [ofp_parser.OFPBucket(weight, watch_port, watch_group,

```



```

                                actions)]

group_id = 1
req = ofp_parser.OFPGroupMod(datapath, ofp.OFPGC_ADD,
                                ofp.OFPGT_SELECT, group_id, buckets)
datapath.send_msg(req)

```

JSON Example:

```

{
  "OFPGroupMod": {
    "buckets": [
      {
        "OFPBucket": {
          "actions": [
            {
              "OFPActionOutput": {
                "len": 16,
                "max_len": 65535,
                "port": 2,
                "type": 0
              }
            }
          ],
          "len": 32,
          "watch_group": 1,
          "watch_port": 1,
          "weight": 1
        }
      }
    ],
    "command": 0,
    "group_id": 1,
    "type": 0
  }
}

```

```

class ryu.ofproto.ofproto_v1_3_parser.OFPPortMod(datapath,
                                                    port_no=0,
                                                    hw_addr='00:00:00:00:00:00',
                                                    config=0,
                                                    mask=0,
                                                    advertise=0)

```

Port modification message

The controller sends this message to modify the behavior of the port.

Attribute	Description
port_no	Port number to modify
hw_addr	The hardware address that must be the same as hw_addr of OFPPort of OFPSwitchFeatures
config	Bitmap of configuration flags. OFPPC_PORT_DOWN OFPPC_NO_RECV OFPPC_NO_FWD OFPPC_NO_PACKET_IN
mask	Bitmap of configuration flags above to be changed
advertise	Bitmap of the following flags. OFPPF_10MB_HD OFPPF_10MB_FD OFPPF_100MB_HD OFPPF_100MB_FD OFPPF_1GB_HD OFPPF_1GB_FD OFPPF_10GB_FD OFPPF_40GB_FD OFPPF_100GB_FD OFPPF_1TB_FD OFPPF_OTHER OFPPF_COPPER OFPPF_FIBER OFPPF_AUTONEG OFPPF_PAUSE OFPPF_PAUSE_ASYM

Example:

```
def send_port_mod(self, datapath):
    ofp = datapath.ofproto
    ofp_parser = datapath.ofproto_parser

    port_no = 3
    hw_addr = 'fa:c8:e8:76:1d:7e'
    config = 0
    mask = (ofp.OFPPC_PORT_DOWN | ofp.OFPPC_NO_RECV |
            ofp.OFPPC_NO_FWD | ofp.OFPPC_NO_PACKET_IN)
    advertise = (ofp.OFPPF_10MB_HD | ofp.OFPPF_100MB_FD |
                 ofp.OFPPF_1GB_FD | ofp.OFPPF_COPPER |
                 ofp.OFPPF_AUTONEG | ofp.OFPPF_PAUSE |
                 ofp.OFPPF_PAUSE_ASYM)
    req = ofp_parser.OFPPortMod(datapath, port_no, hw_addr, config,
                                mask, advertise)
    datapath.send_msg(req)
```

JSON Example:

```
{
  "OFPPortMod": {
    "advertise": 4096,
    "config": 0,
    "hw_addr": "00:11:00:00:11:11",
    "mask": 0,
    "port_no": 1
  }
}
```

class ryu.ofproto.ofproto_v1_3_parser.**OFPMeterMod** (*datapath, command=0, flags=1, meter_id=1, bands=None*)

Meter modification message

The controller sends this message to modify the meter.

Attribute	Description
command	One of the following values. OFPMC_ADD OFPMC_MODIFY OFPMC_DELETE
flags	Bitmap of the following flags. OFPMF_KBPS OFPMF_PKTPS OFPMF_BURST OFPMF_STATS
meter_id	Meter instance
bands	list of the following class instance. OFPMeterBandDrop OFPMeterBandDscpRemark OFPMeterBandExperimenter

JSON Example:

```
{
  "OFPMeterMod": {
    "bands": [
      {
        "OFPMeterBandDrop": {
          "burst_size": 10,
          "len": 16,
          "rate": 1000,
          "type": 1
        }
      },
      {
        "OFPMeterBandDscpRemark": {
          "burst_size": 10,
          "len": 16,
          "prec_level": 1,
          "rate": 1000,

```

```

        "type": 2
    },
    {
        "OFPMeterBandExperimenter": {
            "burst_size": 10,
            "experimenter": 999,
            "len": 16,
            "rate": 1000,
            "type": 65535
        }
    }
],
"command": 0,
"flags": 14,
"meter_id": 100
}
}

```

Multipart Messages

class ryu.ofproto.ofproto_v1_3_parser.OFPDescStatsRequest (datapath, flags=0, type=None)

Description statistics request message

The controller uses this message to query description of the switch.

Attribute	Description
flags	Zero or OFPMPF_REQ_MORE

Example:

```

def send_desc_stats_request(self, datapath):
    ofp_parser = datapath.ofproto_parser

    req = ofp_parser.OFPDescStatsRequest(datapath, 0)
    datapath.send_msg(req)

```

JSON Example:

```

{
  "OFPDescStatsRequest": {
    "flags": 0,
    "type": 0
  }
}

```

class ryu.ofproto.ofproto_v1_3_parser.OFPDescStatsReply (datapath, type=None, **kwargs)

Description statistics reply message

The switch responds with this message to a description statistics request.

Attribute	Description
body	Instance of OFPDescStats

Example:

```
@set_ev_cls(ofp_event.EventOFDescStatsReply, MAIN_DISPATCHER)
def desc_stats_reply_handler(self, ev):
    body = ev.msg.body

    self.logger.debug('DescStats: mfr_desc=%s hw_desc=%s sw_desc=%s '
                      'serial_num=%s dp_desc=%s',
                      body.mfr_desc, body.hw_desc, body.sw_desc,
                      body.serial_num, body.dp_desc)
```

JSON Example:

```
{
  "OFDescStatsReply": {
    "body": {
      "OFDescStats": {
        "dp_desc": "dp",
        "hw_desc": "hw",
        "mfr_desc": "mfr",
        "serial_num": "serial",
        "sw_desc": "sw"
      }
    },
    "flags": 0,
    "type": 0
  }
}
```

```
class ryu.ofproto.ofproto_v1_3_parser.OFPFlowStatsRequest (datapath,
                                                           flags=0,
                                                           table_id=255,
                                                           out_port=4294967295,
                                                           out_group=4294967295,
                                                           cookie=0, cookie_mask=0,
                                                           match=None,
                                                           type_=None)
```

Individual flow statistics request message

The controller uses this message to query individual flow statistics.

Attribute	Description
flags	Zero or OFPMPF_REQ_MORE
table_id	ID of table to read
out_port	Require matching entries to include this as an output port
out_group	Require matching entries to include this as an output group
cookie	Require matching entries to contain this cookie value
cookie_mask	Mask used to restrict the cookie bits that must match
match	Instance of OFPMatch

Example:

```
def send_flow_stats_request(self, datapath):
    ofp = datapath.ofproto
    ofp_parser = datapath.ofproto_parser

    cookie = cookie_mask = 0
    match = ofp_parser.OFPMatch(in_port=1)
    req = ofp_parser.OFPFlowStatsRequest(datapath, 0,
                                         ofp.OFPTT_ALL,
                                         ofp.OFPP_ANY, ofp.OFPG_ANY,
                                         cookie, cookie_mask,
```

```
datapath.send_msg(req)                                match)
```

JSON Example:

```
{
  "OFPPFlowStatsRequest": {
    "cookie": 0,
    "cookie_mask": 0,
    "flags": 0,
    "match": {
      "OFPMatch": {
        "length": 4,
        "oxm_fields": [],
        "type": 1
      }
    },
    "out_group": 4294967295,
    "out_port": 4294967295,
    "table_id": 0,
    "type": 1
  }
}
```

class ryu.ofproto.ofproto_v1_3_parser.**OFPPFlowStatsReply** (*datapath*, *type_=None*, ***kwargs*)

Individual flow statistics reply message

The switch responds with this message to an individual flow statistics request.

Attribute	Description
body	List of OFPPFlowStats instance

Example:

```
@set_ev_cls(ofp_event.EventOFPPFlowStatsReply, MAIN_DISPATCHER)
def flow_stats_reply_handler(self, ev):
    flows = []
    for stat in ev.msg.body:
        flows.append('table_id=%s '
                    'duration_sec=%d duration_nsec=%d '
                    'priority=%d '
                    'idle_timeout=%d hard_timeout=%d flags=0x%04x '
                    'cookie=%d packet_count=%d byte_count=%d '
                    'match=%s instructions=%s' %
                    (stat.table_id,
                     stat.duration_sec, stat.duration_nsec,
                     stat.priority,
                     stat.idle_timeout, stat.hard_timeout, stat.flags,
                     stat.cookie, stat.packet_count, stat.byte_count,
                     stat.match, stat.instructions))
    self.logger.debug('FlowStats: %s', flows)
```

JSON Example:

```
{
  "OFPPFlowStatsReply": {
    "body": [
      {
        "OFPPFlowStats": {
```

```

        "byte_count": 0,
        "cookie": 0,
        "duration_nsec": 115277000,
        "duration_sec": 358,
        "flags": 0,
        "hard_timeout": 0,
        "idle_timeout": 0,
        "instructions": [],
        "length": 56,
        "match": {
            "OFPMatch": {
                "length": 4,
                "oxm_fields": [],
                "type": 1
            }
        },
        "packet_count": 0,
        "priority": 65535,
        "table_id": 0
    },
    {
        "OFPPFlowStats": {
            "byte_count": 0,
            "cookie": 0,
            "duration_nsec": 115055000,
            "duration_sec": 358,
            "flags": 0,
            "hard_timeout": 0,
            "idle_timeout": 0,
            "instructions": [
                {
                    "OFPIInstructionActions": {
                        "actions": [
                            {
                                "OFPAActionOutput": {
                                    "len": 16,
                                    "max_len": 0,
                                    "port": 4294967290,
                                    "type": 0
                                }
                            }
                        ],
                        "len": 24,
                        "type": 4
                    }
                }
            ],
            "length": 88,
            "match": {
                "OFPMatch": {
                    "length": 10,
                    "oxm_fields": [
                        {
                            "OXMTlv": {
                                "field": "eth_type",
                                "mask": null,
                                "value": 2054
                            }
                        }
                    ]
                }
            }
        }
    }
]

```

```

        }
    },
    "type": 1
}
},
"packet_count": 0,
"priority": 65534,
"table_id": 0
}
},
{
  "OFPPFlowStats": {
    "byte_count": 238,
    "cookie": 0,
    "duration_nsec": 511582000,
    "duration_sec": 316220,
    "flags": 0,
    "hard_timeout": 0,
    "idle_timeout": 0,
    "instructions": [
      {
        "OFPIInstructionGotoTable": {
          "len": 8,
          "table_id": 1,
          "type": 1
        }
      }
    ],
    "length": 80,
    "match": {
      "OFPMatch": {
        "length": 22,
        "oxm_fields": [
          {
            "OXMTlv": {
              "field": "in_port",
              "mask": null,
              "value": 6
            }
          },
          {
            "OXMTlv": {
              "field": "eth_src",
              "mask": null,
              "value": "f2:0b:a4:7d:f8:ea"
            }
          }
        ],
        "type": 1
      }
    },
    "packet_count": 3,
    "priority": 123,
    "table_id": 0
  }
},
{

```



```

"OFPPFlowStats": {
  "byte_count": 98,
  "cookie": 0,
  "duration_nsec": 980901000,
  "duration_sec": 313499,
  "flags": 0,
  "hard_timeout": 0,
  "idle_timeout": 0,
  "instructions": [
    {
      "OFPIInstructionActions": {
        "actions": [
          {
            "OFPAActionSetField": {
              "field": {
                "OXMTlv": {
                  "field": "vlan_vid",
                  "mask": null,
                  "value": 258
                }
              }
            },
            "len": 16,
            "type": 25
          },
          {
            "OFPAActionCopyTtlOut": {
              "len": 8,
              "type": 11
            }
          },
          {
            "OFPAActionCopyTtlIn": {
              "len": 8,
              "type": 12
            }
          },
          {
            "OFPAActionCopyTtlIn": {
              "len": 8,
              "type": 12
            }
          },
          {
            "OFPAActionPopPbb": {
              "len": 8,
              "type": 27
            }
          },
          {
            "OFPAActionPushPbb": {
              "ethertype": 4660,
              "len": 8,
              "type": 26
            }
          },
          {
            "OFPAActionPopMpls": {

```

```
        "ethertype": 39030,
        "len": 8,
        "type": 20
    },
    {
        "OFPActionPushMpls": {
            "ethertype": 34887,
            "len": 8,
            "type": 19
        }
    },
    {
        "OFPActionPopVlan": {
            "len": 8,
            "type": 18
        }
    },
    {
        "OFPActionPushVlan": {
            "ethertype": 33024,
            "len": 8,
            "type": 17
        }
    },
    {
        "OFPActionDecMplsTtl": {
            "len": 8,
            "type": 16
        }
    },
    {
        "OFPActionSetMplsTtl": {
            "len": 8,
            "mpls_ttl": 10,
            "type": 15
        }
    },
    {
        "OFPActionDecNwTtl": {
            "len": 8,
            "type": 24
        }
    },
    {
        "OFPActionSetNwTtl": {
            "len": 8,
            "nw_ttl": 10,
            "type": 23
        }
    },
    {
        "OFPActionSetQueue": {
            "len": 8,
            "queue_id": 3,
            "type": 21
        }
    }
},
```

```

    {
      "OFPActionGroup": {
        "group_id": 99,
        "len": 8,
        "type": 22
      }
    },
    {
      "OFPActionOutput": {
        "len": 16,
        "max_len": 65535,
        "port": 6,
        "type": 0
      }
    },
    {
      "OFPActionExperimenterUnknown": {
        "len": 16,
        "data": "ZXhwX2RhdGE=",
        "experimenter": 98765432,
        "type": 65535
      }
    },
    {
      "NXActionUnknown": {
        "len": 16,
        "data": "cF9kYXRh",
        "experimenter": 8992,
        "type": 65535,
        "subtype": 25976
      }
    }
  ],
  "len": 192,
  "type": 3
}
},
{
  "OFPInstructionActions": {
    "actions": [
      {
        "OFPActionSetField": {
          "field": {
            "OXMTlv": {
              "field": "eth_src",
              "mask": null,
              "value": "01:02:03:04:05:06"
            }
          }
        },
        "len": 16,
        "type": 25
      }
    ],
    "OFPActionSetField": {
      "field": {
        "OXMTlv": {
          "field": "pbb_uca",

```

```

        "mask": null,
        "value": 1
    }
},
"len": 16,
"type": 25
}
}
],
"len": 40,
"type": 4
}
},
{
    "OFPInstructionActions": {
        "actions": [
            {
                "OFPActionOutput": {
                    "len": 16,
                    "max_len": 65535,
                    "port": 4294967293,
                    "type": 0
                }
            }
        ],
        "len": 24,
        "type": 3
    }
}
],
"length": 312,
"match": {
    "OFPMatch": {
        "length": 4,
        "oxm_fields": [],
        "type": 1
    }
},
"packet_count": 1,
"priority": 0,
"table_id": 0
}
}
],
"flags": 0,
"type": 1
}
}
}

```

```

class ryu.ofproto.ofproto_v1_3_parser.OFPAggregateStatsRequest (datapath, flags,
                                                                table_id, out_port,
                                                                out_group, cookie,
                                                                cookie_mask,
                                                                match,
                                                                type_=None)

```

Aggregate flow statistics request message

The controller uses this message to query aggregate flow statistics.

Attribute	Description
flags	Zero or OFPMPF_REQ_MORE
table_id	ID of table to read
out_port	Require matching entries to include this as an output port
out_group	Require matching entries to include this as an output group
cookie	Require matching entries to contain this cookie value
cookie_mask	Mask used to restrict the cookie bits that must match
match	Instance of OFPMatch

Example:

```
def send_aggregate_stats_request(self, datapath):
    ofp = datapath.ofproto
    ofp_parser = datapath.ofproto_parser

    cookie = cookie_mask = 0
    match = ofp_parser.OFPMatch(in_port=1)
    req = ofp_parser.OFPAggregateStatsRequest(datapath, 0,
                                              ofp.OFPTT_ALL,
                                              ofp.OFPP_ANY,
                                              ofp.OFPG_ANY,
                                              cookie, cookie_mask,
                                              match)

    datapath.send_msg(req)
```

JSON Example:

```
{
  "OFPAggregateStatsRequest": {
    "cookie": 0,
    "cookie_mask": 0,
    "flags": 0,
    "match": {
      "OFPMatch": {
        "length": 4,
        "oxm_fields": [],
        "type": 1
      }
    },
    "out_group": 4294967295,
    "out_port": 4294967295,
    "table_id": 255,
    "type": 2
  }
}
```

class ryu.ofproto.ofproto_v1_3_parser.**OFPAggregateStatsReply** (*datapath*, *type_=None*, ***kwargs*)

Aggregate flow statistics reply message

The switch responds with this message to an aggregate flow statistics request.

Attribute	Description
body	Instance of OFPAggregateStats

Example:

```
@set_ev_cls(ofp_event.EventOFPAggregateStatsReply, MAIN_DISPATCHER)
def aggregate_stats_reply_handler(self, ev):
    body = ev.msg.body
```

```
self.logger.debug('AggregateStats: packet_count=%d byte_count=%d '
                  'flow_count=%d',
                  body.packet_count, body.byte_count,
                  body.flow_count)
```

JSON Example:

```
{
  "OFPAggregateStatsReply": {
    "body": {
      "OFPAggregateStats": {
        "byte_count": 574,
        "flow_count": 6,
        "packet_count": 7
      }
    },
    "flags": 0,
    "type": 2
  }
}
```

class ryu.ofproto.ofproto_v1_3_parser.OFPTableStatsRequest (datapath, flags=0, type=None)

Table statistics request message

The controller uses this message to query flow table statistics.

Attribute	Description
flags	Zero or OFPMPF_REQ_MORE

Example:

```
def send_table_stats_request(self, datapath):
    ofp_parser = datapath.ofproto_parser

    req = ofp_parser.OFPTableStatsRequest(datapath, 0)
    datapath.send_msg(req)
```

JSON Example:

```
{
  "OFPTableStatsRequest": {
    "flags": 0,
    "type": 3
  }
}
```

class ryu.ofproto.ofproto_v1_3_parser.OFPTableStatsReply (datapath, type=None, **kwargs)

Table statistics reply message

The switch responds with this message to a table statistics request.

Attribute	Description
body	List of OFPTableStats instance

Example:

```
@set_ev_cls(ofp_event.EventOFPTableStatsReply, MAIN_DISPATCHER)
def table_stats_reply_handler(self, ev):
    tables = []
```

```

for stat in ev.msg.body:
    tables.append('table_id=%d active_count=%d lookup_count=%d '
                 ' matched_count=%d' %
                 (stat.table_id, stat.active_count,
                  stat.lookup_count, stat.matched_count))
self.logger.debug('TableStats: %s', tables)

```

JSON Example:

```

{
  "OFPTableStatsReply": {
    "body": [
      {
        "OFPTableStats": {
          "active_count": 4,
          "lookup_count": 4,
          "matched_count": 4,
          "table_id": 0
        }
      },
      {
        "OFPTableStats": {
          "active_count": 4,
          "lookup_count": 4,
          "matched_count": 4,
          "table_id": 1
        }
      }
    ],
    "flags": 0,
    "type": 3
  }
}

```

```

class ryu.ofproto.ofproto_v1_3_parser.OFPPortStatsRequest (datapath,
                                                           flags=0,
                                                           port_no=4294967295,
                                                           type_=None)

```

Port statistics request message

The controller uses this message to query information about ports statistics.

Attribute	Description
flags	Zero or OFPMPF_REQ_MORE
port_no	Port number to read (OFPP_ANY to all ports)

Example:

```

def send_port_stats_request(self, datapath):
    ofp = datapath.ofproto
    ofp_parser = datapath.ofproto_parser

    req = ofp_parser.OFPPortStatsRequest(datapath, 0, ofp.OFPP_ANY)
    datapath.send_msg(req)

```

JSON Example:

```

{
  "OFPPortStatsRequest": {
    "flags": 0,
    "port_no": 4294967295,

```

```

        "type": 4
    }
}

```

class ryu.ofproto.ofproto_v1_3_parser.**OFPPortStatsReply** (*datapath*, *type_=None*, ***kwargs*)

Port statistics reply message

The switch responds with this message to a port statistics request.

Attribute	Description
body	List of OFPPortStats instance

Example:

```

@set_ev_cls(ofp_event.EventOFPPortStatsReply, MAIN_DISPATCHER)
def port_stats_reply_handler(self, ev):
    ports = []
    for stat in ev.msg.body:
        ports.append('port_no=%d '
                    'rx_packets=%d tx_packets=%d '
                    'rx_bytes=%d tx_bytes=%d '
                    'rx_dropped=%d tx_dropped=%d '
                    'rx_errors=%d tx_errors=%d '
                    'rx_frame_err=%d rx_over_err=%d rx_crc_err=%d '
                    'collisions=%d duration_sec=%d duration_nsec=%d' %
                    (stat.port_no,
                     stat.rx_packets, stat.tx_packets,
                     stat.rx_bytes, stat.tx_bytes,
                     stat.rx_dropped, stat.tx_dropped,
                     stat.rx_errors, stat.tx_errors,
                     stat.rx_frame_err, stat.rx_over_err,
                     stat.rx_crc_err, stat.collisions,
                     stat.duration_sec, stat.duration_nsec))
    self.logger.debug('PortStats: %s', ports)

```

JSON Example:

```

{
  "OFPPortStatsReply": {
    "body": [
      {
        "OFPPortStats": {
          "collisions": 0,
          "duration_nsec": 0,
          "duration_sec": 0,
          "port_no": 7,
          "rx_bytes": 0,
          "rx_crc_err": 0,
          "rx_dropped": 0,
          "rx_errors": 0,
          "rx_frame_err": 0,
          "rx_over_err": 0,
          "rx_packets": 0,
          "tx_bytes": 336,
          "tx_dropped": 0,
          "tx_errors": 0,
          "tx_packets": 4
        }
      }
    ],
  },
}

```



```

    {
        "OFPPortStats": {
            "collisions": 0,
            "duration_nsec": 0,
            "duration_sec": 0,
            "port_no": 6,
            "rx_bytes": 336,
            "rx_crc_err": 0,
            "rx_dropped": 0,
            "rx_errors": 0,
            "rx_frame_err": 0,
            "rx_over_err": 0,
            "rx_packets": 4,
            "tx_bytes": 336,
            "tx_dropped": 0,
            "tx_errors": 0,
            "tx_packets": 4
        }
    },
    "flags": 0,
    "type": 4
}

```

class ryu.ofproto.ofproto_v1_3_parser.OFPPortDescStatsRequest (datapath, flags=0, type_=None)

Port description request message

The controller uses this message to query description of all the ports.

Attribute	Description
flags	Zero or OFPMPF_REQ_MORE

Example:

```

def send_port_desc_stats_request(self, datapath):
    ofp_parser = datapath.ofproto_parser

    req = ofp_parser.OFPPortDescStatsRequest(datapath, 0)
    datapath.send_msg(req)

```

JSON Example:

```

{
  "OFPPortDescStatsRequest": {
    "flags": 0,
    "type": 13
  }
}

```

class ryu.ofproto.ofproto_v1_3_parser.OFPPortDescStatsReply (datapath, type_=None, **kwargs)

Port description reply message

The switch responds with this message to a port description request.

Attribute	Description
body	List of OFPPort instance

Example:

```

@set_ev_cls(ofp_event.EventOFPPortDescStatsReply, MAIN_DISPATCHER)
def port_desc_stats_reply_handler(self, ev):
    ports = []
    for p in ev.msg.body:
        ports.append('port_no=%d hw_addr=%s name=%s config=0x%08x '
                    'state=0x%08x curr=0x%08x advertised=0x%08x '
                    'supported=0x%08x peer=0x%08x curr_speed=%d '
                    'max_speed=%d' %
                    (p.port_no, p.hw_addr,
                     p.name, p.config,
                     p.state, p.curr, p.advertised,
                     p.supported, p.peer, p.curr_speed,
                     p.max_speed))
    self.logger.debug('OFPPortDescStatsReply received: %s', ports)

```

JSON Example:

```

{
  "OFPPortDescStatsReply": {
    "body": [
      {
        "OFPPort": {
          "advertised": 10240,
          "config": 0,
          "curr": 10248,
          "curr_speed": 5000,
          "hw_addr": "f2:0b:a4:d0:3f:70",
          "max_speed": 5000,
          "name": "Port7",
          "peer": 10248,
          "port_no": 7,
          "state": 4,
          "supported": 10248
        }
      },
      {
        "OFPPort": {
          "advertised": 10240,
          "config": 0,
          "curr": 10248,
          "curr_speed": 5000,
          "hw_addr": "f2:0b:a4:7d:f8:ea",
          "max_speed": 5000,
          "name": "Port6",
          "peer": 10248,
          "port_no": 6,
          "state": 4,
          "supported": 10248
        }
      }
    ],
    "flags": 0,
    "type": 13
  }
}

```

```
class ryu.ofproto.ofproto_v1_3_parser.OFPQueueStatsRequest (datapath, flags=0,
port_no=4294967295,
queue_id=4294967295,
type_=None)
```

Queue statistics request message

The controller uses this message to query queue statistics.

Attribute	Description
flags	Zero or OFPMPF_REQ_MORE
port_no	Port number to read
queue_id	ID of queue to read

Example:

```
def send_queue_stats_request(self, datapath):
    ofp = datapath.ofproto
    ofp_parser = datapath.ofproto_parser

    req = ofp_parser.OFPQueueStatsRequest(datapath, 0, ofp.OFPP_ANY,
                                          ofp.OFPQ_ALL)

    datapath.send_msg(req)
```

JSON Example:

```
{
  "OFPQueueStatsRequest": {
    "flags": 0,
    "port_no": 4294967295,
    "queue_id": 4294967295,
    "type": 5
  }
}
```

```
class ryu.ofproto.ofproto_v1_3_parser.OFPQueueStatsReply (datapath, type_=None,
**kwargs)
```

Queue statistics reply message

The switch responds with this message to an aggregate flow statistics request.

Attribute	Description
body	List of OFPQueueStats instance

Example:

```
@set_ev_cls(ofp_event.EventOFPQueueStatsReply, MAIN_DISPATCHER)
def queue_stats_reply_handler(self, ev):
    queues = []
    for stat in ev.msg.body:
        queues.append('port_no=%d queue_id=%d '
                    'tx_bytes=%d tx_packets=%d tx_errors=%d '
                    'duration_sec=%d duration_nsec=%d' %
                    (stat.port_no, stat.queue_id,
                     stat.tx_bytes, stat.tx_packets, stat.tx_errors,
                     stat.duration_sec, stat.duration_nsec))

    self.logger.debug('QueueStats: %s', queues)
```

JSON Example:

```
{
  "OFPQueueStatsReply": {
```

```

    "body": [
      {
        "OFPQueueStats": {
          "duration_nsec": 0,
          "duration_sec": 0,
          "port_no": 7,
          "queue_id": 1,
          "tx_bytes": 0,
          "tx_errors": 0,
          "tx_packets": 0
        }
      },
      {
        "OFPQueueStats": {
          "duration_nsec": 0,
          "duration_sec": 0,
          "port_no": 6,
          "queue_id": 1,
          "tx_bytes": 0,
          "tx_errors": 0,
          "tx_packets": 0
        }
      },
      {
        "OFPQueueStats": {
          "duration_nsec": 0,
          "duration_sec": 0,
          "port_no": 7,
          "queue_id": 2,
          "tx_bytes": 0,
          "tx_errors": 0,
          "tx_packets": 0
        }
      }
    ],
    "flags": 0,
    "type": 5
  }
}

```

class ryu.ofproto.ofproto_v1_3_parser.OFPGroupStatsRequest (datapath, flags=0, group_id=4294967292, type=None)

Group statistics request message

The controller uses this message to query statistics of one or more groups.

Attribute	Description
flags	Zero or OFPMPF_REQ_MORE
group_id	ID of group to read (OFPG_ALL to all groups)

Example:

```

def send_group_stats_request(self, datapath):
    ofp = datapath.ofproto
    ofp_parser = datapath.ofproto_parser

    req = ofp_parser.OFPGroupStatsRequest(datapath, 0, ofp.OFPG_ALL)
    datapath.send_msg(req)

```

class ryu.ofproto.ofproto_v1_3_parser.OFPGroupStatsReply (datapath, type_=None, **kwargs)

Group statistics reply message

The switch responds with this message to a group statistics request.

Attribute	Description
body	List of OFPGroupStats instance

Example:

```
@set_ev_cls(ofp_event.EventOFPGroupStatsReply, MAIN_DISPATCHER)
def group_stats_reply_handler(self, ev):
    groups = []
    for stat in ev.msg.body:
        groups.append('length=%d group_id=%d '
                     'ref_count=%d packet_count=%d byte_count=%d '
                     'duration_sec=%d duration_nsec=%d' %
                     (stat.length, stat.group_id,
                      stat.ref_count, stat.packet_count,
                      stat.byte_count, stat.duration_sec,
                      stat.duration_nsec))
    self.logger.debug('GroupStats: %s', groups)
```

class ryu.ofproto.ofproto_v1_3_parser.OFPGroupDescStatsRequest (datapath, flags=0, type_=None)

Group description request message

The controller uses this message to list the set of groups on a switch.

Attribute	Description
flags	Zero or OFPMPF_REQ_MORE

Example:

```
def send_group_desc_stats_request(self, datapath):
    ofp_parser = datapath.ofproto_parser

    req = ofp_parser.OFPGroupDescStatsRequest(datapath, 0)
    datapath.send_msg(req)
```

JSON Example:

```
{
  "OFPGroupDescStatsRequest": {
    "flags": 0,
    "type": 7
  }
}
```

class ryu.ofproto.ofproto_v1_3_parser.OFPGroupDescStatsReply (datapath, type_=None, **kwargs)

Group description reply message

The switch responds with this message to a group description request.

Attribute	Description
body	List of OFPGroupDescStats instance

Example:

```
@set_ev_cls(ofp_event.EventOFPGroupDescStatsReply, MAIN_DISPATCHER)
def group_desc_stats_reply_handler(self, ev):
    descstats = []
    for stat in ev.msg.body:
        descstats.append('length=%d type=%d group_id=%d '
                        'buckets=%s' %
                        (stat.length, stat.type, stat.group_id,
                         stat.bucket))
    self.logger.debug('GroupDescStats: %s', descstats)
```

JSON Example:

```
{
  "OFPGroupDescStatsReply": {
    "body": [
      {
        "OFPGroupDescStats": {
          "buckets": [
            {
              "OFPBucket": {
                "actions": [
                  {
                    "OFPActionOutput": {
                      "len": 16,
                      "max_len": 65535,
                      "port": 2,
                      "type": 0
                    }
                  }
                ]
              }
            },
            {
              "len": 32,
              "watch_group": 1,
              "watch_port": 1,
              "weight": 1
            }
          ]
        },
        "group_id": 1,
        "length": 40,
        "type": 0
      }
    ],
    "flags": 0,
    "type": 7
  }
}
```

class ryu.ofproto.ofproto_v1_3_parser.OFPGroupFeaturesStatsRequest (*datapath*,
flags=0,
type_=None)

Group features request message

The controller uses this message to list the capabilities of groups on a switch.

Attribute	Description
flags	Zero or OFPMPF_REQ_MORE

Example:

```
def send_group_features_stats_request(self, datapath):
    ofp_parser = datapath.ofproto_parser

    req = ofp_parser.OFPGroupFeaturesStatsRequest(datapath, 0)
    datapath.send_msg(req)
```

JSON Example:

```
{
  "OFPGroupFeaturesStatsRequest": {
    "flags": 0,
    "type": 8
  }
}
```

```
class ryu.ofproto.ofproto_v1_3_parser.OFPGroupFeaturesStatsReply(datapath,
                                                                type_=None,
                                                                **kwargs)
```

Group features reply message

The switch responds with this message to a group features request.

Attribute	Description
body	Instance of OFPGroupFeaturesStats

Example:

```
@set_ev_cls(ofp_event.EventOFPGroupFeaturesStatsReply, MAIN_DISPATCHER)
def group_features_stats_reply_handler(self, ev):
    body = ev.msg.body

    self.logger.debug('GroupFeaturesStats: types=%d '
                      'capabilities=0x%08x max_groups=%s '
                      'actions=%s',
                      body.types, body.capabilities,
                      body.max_groups, body.actions)
```

JSON Example:

```
{
  "OFPGroupFeaturesStatsReply": {
    "body": {
      "OFPGroupFeaturesStats": {
        "actions": [
          67082241,
          67082241,
          67082241,
          67082241
        ],
        "capabilities": 5,
        "max_groups": [
          16777216,
          16777216,
          16777216,
          16777216
        ],
        "types": 15
      }
    },
    "flags": 0,
  }
}
```

```

        "type": 8
    }
}

```

class ryu.ofproto.ofproto_v1_3_parser.OFPMeterStatsRequest (datapath, flags=0, meter_id=4294967295, type_=None)

Meter statistics request message

The controller uses this message to query statistics for one or more meters.

Attribute	Description
flags	Zero or OFPMPF_REQ_MORE
meter_id	ID of meter to read (OFPM_ALL to all meters)

Example:

```

def send_meter_stats_request(self, datapath):
    ofp = datapath.ofproto
    ofp_parser = datapath.ofproto_parser

    req = ofp_parser.OFPMeterStatsRequest(datapath, 0, ofp.OFPM_ALL)
    datapath.send_msg(req)

```

JSON Example:

```

{
  "OFPMeterStatsRequest": {
    "flags": 0,
    "meter_id": 4294967295,
    "type": 9
  }
}

```

class ryu.ofproto.ofproto_v1_3_parser.OFPMeterStatsReply (datapath, type_=None, **kwargs)

Meter statistics reply message

The switch responds with this message to a meter statistics request.

Attribute	Description
body	List of OFPMeterStats instance

Example:

```

@set_ev_cls(ofp_event.EventOFPMeterStatsReply, MAIN_DISPATCHER)
def meter_stats_reply_handler(self, ev):
    meters = []
    for stat in ev.msg.body:
        meters.append('meter_id=0x%08x len=%d flow_count=%d '
                    'packet_in_count=%d byte_in_count=%d '
                    'duration_sec=%d duration_nsec=%d '
                    'band_stats=%s' %
                    (stat.meter_id, stat.len, stat.flow_count,
                     stat.packet_in_count, stat.byte_in_count,
                     stat.duration_sec, stat.duration_nsec,
                     stat.band_stats))
    self.logger.debug('MeterStats: %s', meters)

```

JSON Example:

```

{
  "OFPMeterStatsReply": {
    "body": [
      {
        "OFPMeterStats": {
          "band_stats": [
            {
              "OFPMeterBandStats": {
                "byte_band_count": 0,
                "packet_band_count": 0
              }
            }
          ],
          "byte_in_count": 0,
          "duration_nsec": 480000,
          "duration_sec": 0,
          "flow_count": 0,
          "len": 56,
          "meter_id": 100,
          "packet_in_count": 0
        }
      }
    ],
    "flags": 0,
    "type": 9
  }
}

```

class ryu.ofproto.ofproto_v1_3_parser.**OFPMeterConfigStatsRequest** (*datapath*, *flags=0*, *meter_id=4294967295*, *type_=None*)

Meter configuration statistics request message

The controller uses this message to query configuration for one or more meters.

Attribute	Description
flags	Zero or OFPMPF_REQ_MORE
meter_id	ID of meter to read (OFPM_ALL to all meters)

Example:

```

def send_meter_config_stats_request(self, datapath):
    ofp = datapath.ofproto
    ofp_parser = datapath.ofproto_parser

    req = ofp_parser.OFPMeterConfigStatsRequest(datapath, 0,
                                                  ofp.OFPM_ALL)

    datapath.send_msg(req)

```

JSON Example:

```

{
  "OFPMeterConfigStatsRequest": {
    "flags": 0,
    "meter_id": 4294967295,
    "type": 10
  }
}

```

```
class ryu.ofproto.ofproto_v1_3_parser.OFPMeterConfigStatsReply (datapath,
                                                                type_=None,
                                                                **kwargs)
```

Meter configuration statistics reply message

The switch responds with this message to a meter configuration statistics request.

Attribute	Description
body	List of OFPMeterConfigStats instance

Example:

```
@set_ev_cls(ofp_event.EventOFPMeterConfigStatsReply, MAIN_DISPATCHER)
def meter_config_stats_reply_handler(self, ev):
    configs = []
    for stat in ev.msg.body:
        configs.append('length=%d flags=0x%04x meter_id=0x%08x '
                      'bands=%s' %
                      (stat.length, stat.flags, stat.meter_id,
                       stat.bands))
    self.logger.debug('MeterConfigStats: %s', configs)
```

JSON Example:

```
{
  "OFPMeterConfigStatsReply": {
    "body": [
      {
        "OFPMeterConfigStats": {
          "bands": [
            {
              "OFPMeterBandDrop": {
                "burst_size": 10,
                "len": 16,
                "rate": 1000,
                "type": 1
              }
            }
          ],
          "flags": 14,
          "length": 24,
          "meter_id": 100
        }
      }
    ],
    "flags": 0,
    "type": 10
  }
}
```

```
class ryu.ofproto.ofproto_v1_3_parser.OFPMeterFeaturesStatsRequest (datapath,
                                                                        flags=0,
                                                                        type_=None)
```

Meter features statistics request message

The controller uses this message to query the set of features of the metering subsystem.

Attribute	Description
flags	Zero or OFPMPF_REQ_MORE

Example:

```
def send_meter_features_stats_request(self, datapath):
    ofp_parser = datapath.ofproto_parser

    req = ofp_parser.OFPMeterFeaturesStatsRequest(datapath, 0)
    datapath.send_msg(req)
```

JSON Example:

```
{
  "OFPMeterFeaturesStatsRequest": {
    "flags": 0,
    "type": 11
  }
}
```

```
class ryu.ofproto.ofproto_v1_3_parser.OFPMeterFeaturesStatsReply(datapath,
                                                                type_=None,
                                                                **kwargs)
```

Meter features statistics reply message

The switch responds with this message to a meter features statistics request.

Attribute	Description
body	List of OFPMeterFeaturesStats instance

Example:

```
@set_ev_cls(ofp_event.EventOFPMeterFeaturesStatsReply, MAIN_DISPATCHER)
def meter_features_stats_reply_handler(self, ev):
    features = []
    for stat in ev.msg.body:
        features.append('max_meter=%d band_types=0x%08x '
                       'capabilities=0x%08x max_bands=%d '
                       'max_color=%d' %
                       (stat.max_meter, stat.band_types,
                        stat.capabilities, stat.max_bands,
                        stat.max_color))
    self.logger.debug('MeterFeaturesStats: %s', features)
```

JSON Example:

```
{
  "OFPMeterFeaturesStatsReply": {
    "body": [
      {
        "OFPMeterFeaturesStats": {
          "band_types": 2147483654,
          "capabilities": 15,
          "max_bands": 255,
          "max_color": 0,
          "max_meter": 16777216
        }
      }
    ],
    "flags": 0,
    "type": 11
  }
}
```

class ryu.ofproto.ofproto_v1_3_parser.OFPTableFeaturesStatsRequest (*datapath*,
flags=0,
body=None,
type_=None)

Table features statistics request message

The controller uses this message to query table features.

Attribute	Description
body	List of OFPTableFeaturesStats instances. The default is [].

class ryu.ofproto.ofproto_v1_3_parser.OFPTableFeaturesStatsReply (*datapath*,
type_=None,
***kwargs*)

Table features statistics reply message

The switch responds with this message to a table features statistics request.

Attribute	Description
body	List of OFPTableFeaturesStats instance

JSON Example:

See an example in:

`ryu/tests/unit/ofproto/json/of13/4-56-ofp_table_features_reply.packet.json`

Queue Configuration Messages

class ryu.ofproto.ofproto_v1_3_parser.OFPQueueGetConfigRequest (*datapath*, *port*)
 Queue configuration request message

Attribute	Description
port	Port to be queried (OFPP_ANY to all configured queues)

Example:

```
def send_queue_get_config_request(self, datapath):
    ofp = datapath.ofproto
    ofp_parser = datapath.ofproto_parser

    req = ofp_parser.OFPQueueGetConfigRequest(datapath, ofp.OFPP_ANY)
    datapath.send_msg(req)
```

JSON Example:

```
{
  "OFPQueueGetConfigRequest": {
    "port": 4294967295
  }
}
```

class ryu.ofproto.ofproto_v1_3_parser.OFPQueueGetConfigReply (*datapath*,
queues=None,
port=None)

Queue configuration reply message

The switch responds with this message to a queue configuration request.

Attribute	Description
queues	list of OFPPacketQueue instance
port	Port which was queried

Example:

```
@set_ev_cls(ofp_event.EventOFPPQueueGetConfigReply, MAIN_DISPATCHER)
def queue_get_config_reply_handler(self, ev):
    msg = ev.msg

    self.logger.debug('OFPPQueueGetConfigReply received: '
                      'port=%s queues=%s',
                      msg.port, msg.queues)
```

JSON Example:

```
{
  "OFPPQueueGetConfigReply": {
    "port": 4294967295,
    "queues": [
      {
        "OFPPacketQueue": {
          "len": 64,
          "port": 77,
          "properties": [
            {
              "OFPPQueuePropMinRate": {
                "len": 16,
                "property": 1,
                "rate": 10
              }
            },
            {
              "OFPPQueuePropMaxRate": {
                "len": 16,
                "property": 2,
                "rate": 900
              }
            },
            {
              "OFPPQueuePropExperimenter": {
                "data": [],
                "experimenter": 999,
                "len": 16,
                "property": 65535
              }
            }
          ],
          "queue_id": 99
        }
      },
      {
        "OFPPacketQueue": {
          "len": 65,
          "port": 77,
          "properties": [
            {
              "OFPPQueuePropMinRate": {
                "len": 16,
                "property": 1,
                "rate": 100
              }
            }
          ]
        }
      }
    ]
  }
}
```

```

        {
            "OFPPacketQueue": {
                "len": 66,
                "port": 77,
                "properties": [
                    {
                        "OFPPQueuePropMinRate": {
                            "len": 16,
                            "property": 1,
                            "rate": 200
                        }
                    },
                    {
                        "OFPPQueuePropMaxRate": {
                            "len": 16,
                            "property": 2,
                            "rate": 400
                        }
                    },
                    {
                        "OFPPQueuePropExperimenter": {
                            "experimenter": 999,
                            "data": [
                                1,
                                2
                            ],
                            "len": 18,
                            "property": 65535
                        }
                    }
                ],
                "queue_id": 77
            }
        },
        {
            "OFPPacketQueue": {
                "len": 66,
                "port": 77,
                "properties": [
                    {
                        "OFPPQueuePropMinRate": {
                            "len": 16,
                            "property": 1,
                            "rate": 200
                        }
                    },
                    {
                        "OFPPQueuePropMaxRate": {
                            "len": 16,
                            "property": 2,
                            "rate": 400
                        }
                    },
                    {
                        "OFPPQueuePropExperimenter": {
                            "experimenter": 999,
                            "data": [
                                1,
                                2
                            ],
                            "len": 18,
                            "property": 65535
                        }
                    }
                ],
                "queue_id": 88
            }
        }
    ],
    "queue_id": 88
}

```

Packet-Out Message

```
class ryu.ofproto.ofproto_v1_3_parser.OFPPacketOut (datapath, buffer_id=None,
in_port=None, actions=None,
data=None, actions_len=None)
```

Packet-Out message

The controller uses this message to send a packet out through the switch.

Attribute	Description
buffer_id	ID assigned by datapath (OFP_NO_BUFFER if none)
in_port	Packet's input port or OFPP_CONTROLLER
actions	list of OpenFlow action class
data	Packet data

Example:

```
def send_packet_out(self, datapath, buffer_id, in_port):
    ofp = datapath.ofproto
    ofp_parser = datapath.ofproto_parser

    actions = [ofp_parser.OFPPActionOutput(ofp.OFPFLOOD, 0)]
    req = ofp_parser.OFPPacketOut(datapath, buffer_id,
                                   in_port, actions)

    datapath.send_msg(req)
```

JSON Example:

```
{
  "OFPPacketOut": {
    "actions": [
      {
        "OFPPActionOutput": {
          "len": 16,
          "max_len": 65535,
          "port": 4294967292,
          "type": 0
        }
      }
    ],
    "actions_len": 16,
    "buffer_id": 4294967295,
    "data": "8guk0D9w8gukffjqCABFAABU+BoAAP8Br4sKAAABCgAAAggAAgj3YAAAMdYCAAAAACrjS0xAAAAABARE",
    "in_port": 4294967293
  }
}
```

Barrier Message

```
class ryu.ofproto.ofproto_v1_3_parser.OFPBarrierRequest (datapath)
Barrier request message
```

The controller sends this message to ensure message dependencies have been met or receive notifications for completed operations.

Example:

```
def send_barrier_request(self, datapath):
    ofp_parser = datapath.ofproto_parser

    req = ofp_parser.OFPBarrierRequest(datapath)
    datapath.send_msg(req)
```

JSON Example:

```
{
  "OFPBarrierRequest": {}
}
```

class ryu.ofproto.ofproto_v1_3_parser.OFPBarrierReply(*datapath*)
Barrier reply message

The switch responds with this message to a barrier request.

Example:

```
@set_ev_cls(ofp_event.EventOFPBarrierReply, MAIN_DISPATCHER)
def barrier_reply_handler(self, ev):
    self.logger.debug('OFPBarrierReply received')
```

JSON Example:

```
{
  "OFPBarrierReply": {}
}
```

Role Request Message

class ryu.ofproto.ofproto_v1_3_parser.OFPRoleRequest(*datapath*, *role=None*, *generation_id=None*)

Role request message

The controller uses this message to change its role.

Attribute	Description
role	One of the following values. OFPCR_ROLE_NOCHANGE OFPCR_ROLE_EQUAL OFPCR_ROLE_MASTER OFPCR_ROLE_SLAVE
generation_id	Master Election Generation ID

Example:

```
def send_role_request(self, datapath):
    ofp = datapath.ofproto
    ofp_parser = datapath.ofproto_parser

    req = ofp_parser.OFPRoleRequest(datapath, ofp.OFPCR_ROLE_EQUAL, 0)
    datapath.send_msg(req)
```

JSON Example:

```
{
  "OFPPRoleRequest": {
    "generation_id": 17294086455919964160,
    "role": 2
  }
}
```

class ryu.ofproto.ofproto_v1_3_parser.**OFPPRoleReply** (*datapath*, *role=None*, *generation_id=None*)

Role reply message

The switch responds with this message to a role request.

Attribute	Description
role	One of the following values. OFPPCR_ROLE_NOCHANGE OFPPCR_ROLE_EQUAL OFPPCR_ROLE_MASTER OFPPCR_ROLE_SLAVE
generation_id	Master Election Generation ID

Example:

```
@set_ev_cls(ofp_event.EventOFPPRoleReply, MAIN_DISPATCHER)
def role_reply_handler(self, ev):
    msg = ev.msg
    dp = msg.datapath
    ofp = dp.ofproto

    if msg.role == ofp.OFPPCR_ROLE_NOCHANGE:
        role = 'NOCHANGE'
    elif msg.role == ofp.OFPPCR_ROLE_EQUAL:
        role = 'EQUAL'
    elif msg.role == ofp.OFPPCR_ROLE_MASTER:
        role = 'MASTER'
    elif msg.role == ofp.OFPPCR_ROLE_SLAVE:
        role = 'SLAVE'
    else:
        role = 'unknown'

    self.logger.debug('OFPPRoleReply received: '
                      'role=%s generation_id=%d',
                      role, msg.generation_id)
```

JSON Example:

```
{
  "OFPPRoleReply": {
    "generation_id": 17294086455919964160,
    "role": 3
  }
}
```

Set Asynchronous Configuration Message

```
class ryu.ofproto.ofproto_v1_3_parser.OFPSetAsync (datapath, packet_in_mask,
                                                    port_status_mask,
                                                    flow_removed_mask)
```

Set asynchronous configuration message

The controller sends this message to set the asynchronous messages that it wants to receive on a given OpneFlow channel.

Attribute	Description
packet_in_mask	2-element array: element 0, when the controller has a OFPCR_ROLE_EQUAL or OFPCR_ROLE_MASTER role. element 1, OFPCR_ROLE_SLAVE role controller. Bitmasks of following values. OFPR_NO_MATCH OFPR_ACTION OFPR_INVALID_TTL
port_status_mask	2-element array. Bitmasks of following values. OFPPR_ADD OFPPR_DELETE OFPPR_MODIFY
flow_removed_mask	2-element array. Bitmasks of following values. OFPRR_IDLE_TIMEOUT OFPRR_HARD_TIMEOUT OFPRR_DELETE OFPRR_GROUP_DELETE

Example:

```
def send_set_async(self, datapath):
    ofp = datapath.ofproto
    ofp_parser = datapath.ofproto_parser

    packet_in_mask = ofp.OFPR_ACTION | ofp.OFPR_INVALID_TTL
    port_status_mask = (ofp.OFPPR_ADD | ofp.OFPPR_DELETE |
                       ofp.OFPPR_MODIFY)
    flow_removed_mask = (ofp.OFPRR_IDLE_TIMEOUT |
                        ofp.OFPRR_HARD_TIMEOUT |
                        ofp.OFPRR_DELETE)
    req = ofp_parser.OFPSetAsync(datapath,
                                 [packet_in_mask, 0],
                                 [port_status_mask, 0],
                                 [flow_removed_mask, 0])

    datapath.send_msg(req)
```

JSON Example:

```

{
  "OFPSyncRequest": {
    "flow_removed_mask": [
      15,
      3
    ],
    "packet_in_mask": [
      5,
      1
    ],
    "port_status_mask": [
      7,
      3
    ]
  }
}

```

class ryu.ofproto.ofproto_v1_3_parser.**OFPSyncRequest** (*datapath*)
Get asynchronous configuration request message

The controller uses this message to query the asynchronous message.

Example:

```

def send_get_async_request(self, datapath):
    ofp_parser = datapath.ofproto_parser

    req = ofp_parser.OFPSyncRequest(datapath)
    datapath.send_msg(req)

```

JSON Example:

```

{
  "OFPSyncRequest": {}
}

```

class ryu.ofproto.ofproto_v1_3_parser.**OFPSyncReply** (*datapath*,
packet_in_mask=None,
port_status_mask=None,
flow_removed_mask=None)

Get asynchronous configuration reply message

The switch responds with this message to a get asynchronous configuration request.

Attribute	Description
packet_in_mask	2-element array: element 0, when the controller has a OFPCR_ROLE_EQUAL or OFPCR_ROLE_MASTER role. element 1, OFPCR_ROLE_SLAVE role controller. Bitmasks of following values. OFPR_NO_MATCH OFPR_ACTION OFPR_INVALID_TTL
port_status_mask	2-element array. Bitmasks of following values. OFPPR_ADD OFPPR_DELETE OFPPR_MODIFY
flow_removed_mask	2-element array. Bitmasks of following values. OFPRR_IDLE_TIMEOUT OFPRR_HARD_TIMEOUT OFPRR_DELETE OFPRR_GROUP_DELETE

Example:

```
@set_ev_cls(ofp_event.EventOFPGetAsyncReply, MAIN_DISPATCHER)
def get_async_reply_handler(self, ev):
    msg = ev.msg

    self.logger.debug('OFPGetAsyncReply received: '
                      'packet_in_mask=0x%08x:0x%08x '
                      'port_status_mask=0x%08x:0x%08x '
                      'flow_removed_mask=0x%08x:0x%08x',
                      msg.packet_in_mask[0],
                      msg.packet_in_mask[1],
                      msg.port_status_mask[0],
                      msg.port_status_mask[1],
                      msg.flow_removed_mask[0],
                      msg.flow_removed_mask[1])
```

JSON Example:

```
{
  "OFPGetAsyncReply": {
    "flow_removed_mask": [
      15,
      3
    ],
    "packet_in_mask": [
      5,
      1
    ],
    "port_status_mask": [
      7,
```

```

        3
    ]
}
}

```

Asynchronous Messages

Packet-In Message

```

class ryu.ofproto.ofproto_v1_3_parser.OFPPacketIn (datapath, buffer_id=None, total_len=None, reason=None, table_id=None, cookie=None, match=None, data=None)

```

Packet-In message

The switch sends the packet that received to the controller by this message.

Attribute	Description
buffer_id	ID assigned by datapath
total_len	Full length of frame
reason	Reason packet is being sent. OFPR_NO_MATCH OFPR_ACTION OFPR_INVALID_TTL
table_id	ID of the table that was looked up
cookie	Cookie of the flow entry that was looked up
match	Instance of OFPMatch
data	Ethernet frame

Example:

```

@set_ev_cls(ofp_event.EventOFPPacketIn, MAIN_DISPATCHER)
def packet_in_handler(self, ev):
    msg = ev.msg
    dp = msg.datapath
    ofp = dp.ofproto

    if msg.reason == ofp.OFPR_NO_MATCH:
        reason = 'NO MATCH'
    elif msg.reason == ofp.OFPR_ACTION:
        reason = 'ACTION'
    elif msg.reason == ofp.OFPR_INVALID_TTL:
        reason = 'INVALID TTL'
    else:
        reason = 'unknown'

    self.logger.debug('OFPPacketIn received: '
                      'buffer_id=%x total_len=%d reason=%s '
                      'table_id=%d cookie=%d match=%s data=%s',
                      msg.buffer_id, msg.total_len, reason,
                      msg.table_id, msg.cookie, msg.match,
                      utils.hex_array(msg.data))

```

JSON Example:

```
{
  "OFPPacketIn": {
    "buffer_id": 2,
    "cookie": 2836868884868096,
    "data": "/////////8gukffjqCAYAAQgABgQAAfILpH346goAAAEAAAAAAAAAKAAD",
    "match": {
      "OFPMatch": {
        "length": 80,
        "oxm_fields": [
          {
            "OXMTlv": {
              "field": "in_port",
              "mask": null,
              "value": 6
            }
          },
          {
            "OXMTlv": {
              "field": "eth_type",
              "mask": null,
              "value": 2054
            }
          },
          {
            "OXMTlv": {
              "field": "eth_dst",
              "mask": null,
              "value": "ff:ff:ff:ff:ff:ff"
            }
          },
          {
            "OXMTlv": {
              "field": "eth_src",
              "mask": null,
              "value": "f2:0b:a4:7d:f8:ea"
            }
          },
          {
            "OXMTlv": {
              "field": "arp_op",
              "mask": null,
              "value": 1
            }
          },
          {
            "OXMTlv": {
              "field": "arp_spa",
              "mask": null,
              "value": "10.0.0.1"
            }
          },
          {
            "OXMTlv": {
              "field": "arp_tpa",
              "mask": null,
              "value": "10.0.0.3"
            }
          }
        ]
      }
    }
  }
}
```

```

    {
        "OXMTlv": {
            "field": "arp_sha",
            "mask": null,
            "value": "f2:0b:a4:7d:f8:ea"
        }
    },
    {
        "OXMTlv": {
            "field": "arp_tha",
            "mask": null,
            "value": "00:00:00:00:00:00"
        }
    }
],
"type": 1
}
},
"reason": 1,
"table_id": 1,
"total_len": 42
}
}

```

Flow Removed Message

```

class ryu.ofproto.ofproto_v1_3_parser.OFPFlowRemoved(datapath, cookie=None, priority=None, reason=None, table_id=None, duration_sec=None, duration_nsec=None, idle_timeout=None, hard_timeout=None, packet_count=None, byte_count=None, match=None)

```

Flow removed message

When flow entries time out or are deleted, the switch notifies controller with this message.

Attribute	Description
cookie	Opaque controller-issued identifier
priority	Priority level of flow entry
reason	One of the following values. OFPRR_IDLE_TIMEOUT OFPRR_HARD_TIMEOUT OFPRR_DELETE OFPRR_GROUP_DELETE
table_id	ID of the table
duration_sec	Time flow was alive in seconds
duration_nsec	Time flow was alive in nanoseconds beyond duration_sec
idle_timeout	Idle timeout from original flow mod
hard_timeout	Hard timeout from original flow mod
packet_count	Number of packets that was associated with the flow
byte_count	Number of bytes that was associated with the flow
match	Instance of OFPMatch

Example:

```
@set_ev_cls(ofp_event.EventOFPPFlowRemoved, MAIN_DISPATCHER)
def flow_removed_handler(self, ev):
    msg = ev.msg
    dp = msg.datapath
    ofp = dp.ofproto

    if msg.reason == ofp.OFPRR_IDLE_TIMEOUT:
        reason = 'IDLE TIMEOUT'
    elif msg.reason == ofp.OFPRR_HARD_TIMEOUT:
        reason = 'HARD TIMEOUT'
    elif msg.reason == ofp.OFPRR_DELETE:
        reason = 'DELETE'
    elif msg.reason == ofp.OFPRR_GROUP_DELETE:
        reason = 'GROUP DELETE'
    else:
        reason = 'unknown'

    self.logger.debug('OFPPFlowRemoved received: '
                      'cookie=%d priority=%d reason=%s table_id=%d '
                      'duration_sec=%d duration_nsec=%d '
                      'idle_timeout=%d hard_timeout=%d '
                      'packet_count=%d byte_count=%d match.fields=%s',
                      msg.cookie, msg.priority, reason, msg.table_id,
                      msg.duration_sec, msg.duration_nsec,
                      msg.idle_timeout, msg.hard_timeout,
                      msg.packet_count, msg.byte_count, msg.match)
```

JSON Example:

```
{
  "OFPPFlowRemoved": {
    "byte_count": 86,
    "cookie": 0,
    "duration_nsec": 48825000,
    "duration_sec": 3,
```



```

    "hard_timeout": 0,
    "idle_timeout": 3,
    "match": {
        "OFPMatch": {
            "length": 14,
            "oxm_fields": [
                {
                    "OXMTlv": {
                        "field": "eth_dst",
                        "mask": null,
                        "value": "f2:0b:a4:7d:f8:ea"
                    }
                }
            ],
            "type": 1
        }
    },
    "packet_count": 1,
    "priority": 65535,
    "reason": 0,
    "table_id": 0
}
}

```

Port Status Message

class ryu.ofproto.ofproto_v1_3_parser.**OFPPortStatus** (*datapath*, *reason=None*, *desc=None*)

Port status message

The switch notifies controller of change of ports.

Attribute	Description
reason	One of the following values. OFPPR_ADD OFPPR_DELETE OFPPR_MODIFY
desc	instance of OFPPort

Example:

```

@set_ev_cls(ofp_event.EventOFPPortStatus, MAIN_DISPATCHER)
def port_status_handler(self, ev):
    msg = ev.msg
    dp = msg.datapath
    ofp = dp.ofproto

    if msg.reason == ofp.OFPPR_ADD:
        reason = 'ADD'
    elif msg.reason == ofp.OFPPR_DELETE:
        reason = 'DELETE'
    elif msg.reason == ofp.OFPPR_MODIFY:
        reason = 'MODIFY'
    else:
        reason = 'unknown'

```

```
self.logger.debug('OFPPortStatus received: reason=%s desc=%s',
                  reason, msg.desc)
```

JSON Example:

```
{
  "OFPPortStatus": {
    "desc": {
      "OFPPort": {
        "advertised": 10240,
        "config": 0,
        "curr": 10248,
        "curr_speed": 5000,
        "hw_addr": "f2:0b:a4:d0:3f:70",
        "max_speed": 5000,
        "name": "\u79c1\u306e\u30dd\u30fc\u30c8",
        "peer": 10248,
        "port_no": 7,
        "state": 4,
        "supported": 10248
      }
    },
    "reason": 0
  }
}
```

Error Message

class ryu.ofproto.ofproto_v1_3_parser.**OFPErrormsg**(datapath, type=None, code=None, data=None)

Error message

The switch notifies controller of problems by this message.

Attribute	Description
type	High level type of error
code	Details depending on the type
data	Variable length data depending on the type and code

type attribute corresponds to type_ parameter of `__init__`.

Types and codes are defined in `ryu.ofproto.ofproto`.

Type	Code
OFPET_HELLO_FAILED	OFPHFC_*
OFPET_BAD_REQUEST	OFPBRC_*
OFPET_BAD_ACTION	OFPBAC_*
OFPET_BAD_INSTRUCTION	OFPBIC_*
OFPET_BAD_MATCH	OFPBMC_*
OFPET_FLOW_MOD_FAILED	OFPFMFC_*
OFPET_GROUP_MOD_FAILED	OFPGMFC_*
OFPET_PORT_MOD_FAILED	OFPPMFC_*
OFPET_TABLE_MOD_FAILED	OFPTMFC_*
OFPET_QUEUE_OP_FAILED	OFPQOFC_*
OFPET_SWITCH_CONFIG_FAILED	OFPSCFC_*
OFPET_ROLE_REQUEST_FAILED	OFPRRFC_*
OFPET_METER_MOD_FAILED	OFPMMFC_*
OFPET_TABLE_FEATURES_FAILED	OFPTFFC_*
OFPET_EXPERIMENTER	N/A

Example:

```
@set_ev_cls(ofp_event.EventOFPErrormsg,
            [HANDSHAKE_DISPATCHER, CONFIG_DISPATCHER, MAIN_DISPATCHER])
def error_msg_handler(self, ev):
    msg = ev.msg

    self.logger.debug('OFPErrormsg received: type=0x%02x code=0x%02x '
                      'message=%s',
                      msg.type, msg.code, utils.hex_array(msg.data))
```

JSON Example:

```
{
  "OFPErrormsg": {
    "code": 11,
    "data": "ZnVnYWZ1Z2E=",
    "type": 2
  }
}
```

Symmetric Messages

Hello

class ryu.ofproto.ofproto_v1_3_parser.**OFPHello** (*datapath*, *elements=None*)

Hello message

When connection is started, the hello message is exchanged between a switch and a controller.

This message is handled by the Ryu framework, so the Ryu application do not need to process this typically.

Attribute	Description
elements	list of OFPHelloElemVersionBitmap instance

JSON Example:

```
{
  "OFPHello": {
    "elements": [
```

```

    {
      "OFPHelloElemVersionBitmap": {
        "length": 8,
        "type": 1,
        "versions": [
          1,
          2,
          3,
          9,
          10,
          30
        ]
      }
    }
  ]
}

```

class ryu.ofproto.ofproto_v1_3_parser.**OFPHelloElemVersionBitmap** (*versions*,
type_=None,
length=None)

Version bitmap Hello Element

Attribute	Description
versions	list of versions of OpenFlow protocol a device supports

Echo Request

class ryu.ofproto.ofproto_v1_3_parser.**OFPEchoRequest** (*datapath*, *data=None*)
 Echo request message

This message is handled by the Ryu framework, so the Ryu application do not need to process this typically.

Attribute	Description
data	An arbitrary length data

Example:

```

def send_echo_request(self, datapath, data):
    ofp_parser = datapath.ofproto_parser

    req = ofp_parser.OFPEchoRequest(datapath, data)
    datapath.send_msg(req)

@set_ev_cls(ofp_event.EventOFPEchoRequest,
            [HANDSHAKE_DISPATCHER, CONFIG_DISPATCHER, MAIN_DISPATCHER])
def echo_request_handler(self, ev):
    self.logger.debug('OFPEchoRequest received: data=%s',
                      utils.hex_array(ev.msg.data))

```

JSON Example:

```

{
  "OFPEchoRequest": {
    "data": "aG9nZQ=="
  }
}

```

Echo Reply

class `ryu.ofproto.ofproto_v1_3_parser.OFPEchoReply` (*datapath*, *data=None*)

Echo reply message

This message is handled by the Ryu framework, so the Ryu application do not need to process this typically.

Attribute	Description
<code>data</code>	An arbitrary length data

Example:

```
def send_echo_reply(self, datapath, data):
    ofp_parser = datapath.ofproto_parser

    reply = ofp_parser.OFPEchoReply(datapath, data)
    datapath.send_msg(reply)

@set_ev_cls(ofp_event.EventOFPEchoReply,
            [HANDSHAKE_DISPATCHER, CONFIG_DISPATCHER, MAIN_DISPATCHER])
def echo_reply_handler(self, ev):
    self.logger.debug('OFPEchoReply received: data=%s',
                      utils.hex_array(ev.msg.data))
```

JSON Example:

```
{
  "OFPEchoReply": {
    "data": "aG9nZQ=="
  }
}
```

Experimenter

class `ryu.ofproto.ofproto_v1_3_parser.OFPEExperimenter` (*datapath*, *experimenter=None*, *exp_type=None*, *data=None*)

Experimenter extension message

Attribute	Description
<code>experimenter</code>	Experimenter ID
<code>exp_type</code>	Experimenter defined
<code>data</code>	Experimenter defined arbitrary additional data

JSON Example:

```
{
  "OFPEExperimenter": {
    "data": "bmF6bw==",
    "exp_type": 123456789,
    "experimenter": 98765432
  }
}
```

Port Structures

class `ryu.ofproto.ofproto_v1_3_parser.OFPPort`

Description of a port

Attribute	Description
port_no	Port number and it uniquely identifies a port within a switch.
hw_addr	MAC address for the port.
name	Null-terminated string containing a human-readable name for the interface.
config	Bitmap of port configuration flags. OFPPC_PORT_DOWN OFPPC_NO_RECV OFPPC_NO_FWD OFPPC_NO_PACKET_IN
state	Bitmap of port state flags. OFPPS_LINK_DOWN OFPPS_BLOCKED OFPPS_LIVE
curr	Current features.
advertised	Features being advertised by the port.
supported	Features supported by the port.
peer	Features advertised by peer.
curr_speed	Current port bitrate in kbps.
max_speed	Max port bitrate in kbps.

Flow Match Structure

```
class ryu.ofproto.ofproto_v1_3_parser.OFPMatch (type=None, length=None, _ordered_fields=None, **kwargs)
```

Flow Match Structure

This class is implementation of the flow match structure having compose/query API. There are new API and old API for compatibility. the old API is supposed to be removed later.

You can define the flow match by the keyword arguments. The following arguments are available.

Argument	Value	Description
in_port	Integer 32bit	Switch input port
in_phy_port	Integer 32bit	Switch physical input port
metadata	Integer 64bit	Metadata passed between tables
eth_dst	MAC address	Ethernet destination address
eth_src	MAC address	Ethernet source address
eth_type	Integer 16bit	Ethernet frame type
vlan_vid	Integer 16bit	VLAN id
vlan_pcp	Integer 8bit	VLAN priority
ip_dscp	Integer 8bit	IP DSCP (6 bits in ToS field)
ip_ecn	Integer 8bit	IP ECN (2 bits in ToS field)
ip_proto	Integer 8bit	IP protocol
ipv4_src	IPv4 address	IPv4 source address
ipv4_dst	IPv4 address	IPv4 destination address
tcp_src	Integer 16bit	TCP source port

Continued on next page

Table 2.2 – continued from previous page

Argument	Value	Description
tcp_dst	Integer 16bit	TCP destination port
udp_src	Integer 16bit	UDP source port
udp_dst	Integer 16bit	UDP destination port
sctp_src	Integer 16bit	SCTP source port
sctp_dst	Integer 16bit	SCTP destination port
icmpv4_type	Integer 8bit	ICMP type
icmpv4_code	Integer 8bit	ICMP code
arp_op	Integer 16bit	ARP opcode
arp_spa	IPv4 address	ARP source IPv4 address
arp_tpa	IPv4 address	ARP target IPv4 address
arp_sha	MAC address	ARP source hardware address
arp_tha	MAC address	ARP target hardware address
ipv6_src	IPv6 address	IPv6 source address
ipv6_dst	IPv6 address	IPv6 destination address
ipv6_flabel	Integer 32bit	IPv6 Flow Label
icmpv6_type	Integer 8bit	ICMPv6 type
icmpv6_code	Integer 8bit	ICMPv6 code
ipv6_nd_target	IPv6 address	Target address for ND
ipv6_nd_sll	MAC address	Source link-layer for ND
ipv6_nd_tll	MAC address	Target link-layer for ND
mpls_label	Integer 32bit	MPLS label
mpls_tc	Integer 8bit	MPLS TC
mpls_bos	Integer 8bit	MPLS BoS bit
pbb_isid	Integer 24bit	PBB I-SID
tunnel_id	Integer 64bit	Logical Port Metadata
ipv6_exthdr	Integer 16bit	IPv6 Extension Header pseudo-field
pbb_uca	Integer 8bit	PBB UCA header field (EXT-256 Old version of ONF Extension)
tcp_flags	Integer 16bit	TCP flags (EXT-109 ONF Extension)
actset_output	Integer 32bit	Output port from action set metadata (EXT-233 ONF Extension)

Example:

```

>>> # compose
>>> match = parser.OFPMatch(
...     in_port=1,
...     eth_type=0x86dd,
...     ipv6_src=('2001:db8:bd05:1d2:288a:1fc0:1:10ee',
...               'ffff:ffff:ffff:ffff::'),
...     ipv6_dst='2001:db8:bd05:1d2:288a:1fc0:1:10ee')
>>> # query
>>> if 'ipv6_src' in match:
...     print match['ipv6_src']
...
('2001:db8:bd05:1d2:288a:1fc0:1:10ee', 'ffff:ffff:ffff:ffff::')

```

Note: For the list of the supported Nicira experimenter matches, please refer to [ryu.ofproto.nx_match](#).

Note: For VLAN id match field, special values are defined in OpenFlow Spec.

1. Packets with and without a VLAN tag

•Example:

```
match = parser.OFPMatch()
```

•Packet Matching

non-VLAN-tagged	MATCH
VLAN-tagged(vlan_id=3)	MATCH
VLAN-tagged(vlan_id=5)	MATCH

2.Only packets without a VLAN tag

•Example:

```
match = parser.OFPMatch(vlan_vid=0x0000)
```

•Packet Matching

non-VLAN-tagged	MATCH
VLAN-tagged(vlan_id=3)	x
VLAN-tagged(vlan_id=5)	x

3.Only packets with a VLAN tag regardless of its value

•Example:

```
match = parser.OFPMatch(vlan_vid=(0x1000, 0x1000))
```

•Packet Matching

non-VLAN-tagged	x
VLAN-tagged(vlan_id=3)	MATCH
VLAN-tagged(vlan_id=5)	MATCH

4.Only packets with VLAN tag and VID equal

•Example:

```
match = parser.OFPMatch(vlan_vid=(0x1000 | 3))
```

•Packet Matching

non-VLAN-tagged	x
VLAN-tagged(vlan_id=3)	MATCH
VLAN-tagged(vlan_id=5)	x

Flow Instruction Structures

class ryu.ofproto.ofproto_v1_3_parser.OFPInstructionGotoTable (*table_id*,
type_=None,
len_=None)

Goto table instruction

This instruction indicates the next table in the processing pipeline.

Attribute	Description
table_id	Next table

class ryu.ofproto.ofproto_v1_3_parser.**OFFInstructionWriteMetadata** (*metadata*,
meta-
data_mask,
type_=None,
len_=None)

Write metadata instruction

This instruction writes the masked metadata value into the metadata field.

Attribute	Description
metadata	Metadata value to write
metadata_mask	Metadata write bitmask

class ryu.ofproto.ofproto_v1_3_parser.**OFFInstructionActions** (*type_*, *actions=None*,
len_=None)

Actions instruction

This instruction writes/applies/clears the actions.

Attribute	Description
type	One of following values. OFFPIT_WRITE_ACTIONS OFFPIT_APPLY_ACTIONS OFFPIT_CLEAR_ACTIONS
actions	list of OpenFlow action class

type attribute corresponds to type_ parameter of __init__.

class ryu.ofproto.ofproto_v1_3_parser.**OFFInstructionMeter** (*meter_id=1*, *type_=None*,
len_=None)

Meter instruction

This instruction applies the meter.

Attribute	Description
meter_id	Meter instance

Action Structures

class ryu.ofproto.ofproto_v1_3_parser.**OFFActionOutput** (*port*, *max_len=65509*,
type_=None, *len_=None*)

Output action

This action indicates output a packet to the switch port.

Attribute	Description
port	Output port
max_len	Max length to send to controller

class ryu.ofproto.ofproto_v1_3_parser.**OFFActionGroup** (*group_id=0*, *type_=None*,
len_=None)

Group action

This action indicates the group used to process the packet.

Attribute	Description
group_id	Group identifier

class ryu.ofproto.ofproto_v1_3_parser.**OFFActionSetQueue** (*queue_id*, *type_=None*, *len_=None*)

Set queue action

This action sets the queue id that will be used to map a flow to an already-configured queue on a port.

Attribute	Description
queue_id	Queue ID for the packets

class ryu.ofproto.ofproto_v1_3_parser.**OFFActionSetMplsTtl** (*mpls_ttl*, *type_=None*, *len_=None*)

Set MPLS TTL action

This action sets the MPLS TTL.

Attribute	Description
mpls_ttl	MPLS TTL

class ryu.ofproto.ofproto_v1_3_parser.**OFFActionDecMplsTtl** (*type_=None*, *len_=None*)

Decrement MPLS TTL action

This action decrements the MPLS TTL.

class ryu.ofproto.ofproto_v1_3_parser.**OFFActionSetNwTtl** (*nw_ttl*, *type_=None*, *len_=None*)

Set IP TTL action

This action sets the IP TTL.

Attribute	Description
nw_ttl	IP TTL

class ryu.ofproto.ofproto_v1_3_parser.**OFFActionDecNwTtl** (*type_=None*, *len_=None*)

Decrement IP TTL action

This action decrements the IP TTL.

class ryu.ofproto.ofproto_v1_3_parser.**OFFActionCopyTtlOut** (*type_=None*, *len_=None*)

Copy TTL Out action

This action copies the TTL from the next-to-outermost header with TTL to the outermost header with TTL.

class ryu.ofproto.ofproto_v1_3_parser.**OFFActionCopyTtlIn** (*type_=None*, *len_=None*)

Copy TTL In action

This action copies the TTL from the outermost header with TTL to the next-to-outermost header with TTL.

class ryu.ofproto.ofproto_v1_3_parser.**OFFActionPushVlan** (*ethertype=33024*, *type_=None*, *len_=None*)

Push VLAN action

This action pushes a new VLAN tag to the packet.

Attribute	Description
ethertype	Ether type. The default is 802.1Q. (0x8100)

class ryu.ofproto.ofproto_v1_3_parser.**OFFActionPushMpls** (*ethertype=34887*, *type_=None*, *len_=None*)

Push MPLS action

This action pushes a new MPLS header to the packet.

Attribute	Description
ethertype	Ether type

class ryu.ofproto.ofproto_v1_3_parser.OFPActionPopVlan (*type_=None, len_=None*)
Pop VLAN action

This action pops the outermost VLAN tag from the packet.

class ryu.ofproto.ofproto_v1_3_parser.OFPActionPopMpls (*ethertype=2048, type_=None, len_=None*)
Pop MPLS action

This action pops the MPLS header from the packet.

class ryu.ofproto.ofproto_v1_3_parser.OFPActionSetField (*field=None, **kwargs*)
Set field action

This action modifies a header field in the packet.

The set of keywords available for this is same as OFPMatch.

Example:

```
set_field = OFPActionSetField(eth_src="00:00:00:00:00:00")
```

class ryu.ofproto.ofproto_v1_3_parser.OFPActionExperimenter (*experimenter*)
Experimenter action

This action is an extensible action for the experimenter.

Attribute	Description
experimenter	Experimenter ID

Note: For the list of the supported Nicira experimenter actions, please refer to *ryu.ofproto.nx_actions*.

2.5.5 OpenFlow v1.4 Messages and Structures

Controller-to-Switch Messages

Handshake

class ryu.ofproto.ofproto_v1_4_parser.OFPFeaturesRequest (*datapath*)
Features request message

The controller sends a feature request to the switch upon session establishment.

This message is handled by the Ryu framework, so the Ryu application do not need to process this typically.

Example:

```
def send_features_request(self, datapath):
    ofp_parser = datapath.ofproto_parser

    req = ofp_parser.OFPFeaturesRequest(datapath)
    datapath.send_msg(req)
```

JSON Example:

```
{
  "OFPFeaturesRequest": {}
}
```

```
class ryu.ofproto.ofproto_v1_4_parser.OFPSwitchFeatures (datapath, datapath_id=None,
                                                    n_buffers=None,
                                                    n_tables=None,      auxil-
                                                    iary_id=None,      capabili-
                                                    ties=None)
```

Features reply message

The switch responds with a features reply message to a features request.

This message is handled by the Ryu framework, so the Ryu application do not need to process this typically.

Example:

```
@set_ev_cls(ofp_event.EventOFPSwitchFeatures, CONFIG_DISPATCHER)
def switch_features_handler(self, ev):
    msg = ev.msg

    self.logger.debug('OFPSwitchFeatures received: '
                      'datapath_id=0x%016x n_buffers=%d '
                      'n_tables=%d auxiliary_id=%d '
                      'capabilities=0x%08x',
                      msg.datapath_id, msg.n_buffers, msg.n_tables,
                      msg.auxiliary_id, msg.capabilities)
```

JSON Example:

```
{
  "OFPSwitchFeatures": {
    "auxiliary_id": 99,
    "capabilities": 79,
    "datapath_id": 9210263729383,
    "n_buffers": 0,
    "n_tables": 255
  }
}
```

Switch Configuration

```
class ryu.ofproto.ofproto_v1_4_parser.OFPSetConfig (datapath, flags=0, miss_send_len=0)
Set config request message
```

The controller sends a set config request message to set configuraion parameters.

Attribute	Description
flags	Bitmap of the following flags. OFPC_FRAG_NORMAL OFPC_FRAG_DROP OFPC_FRAG_REASM
miss_send_len	Max bytes of new flow that datapath should send to the controller

Example:

```
def send_set_config(self, datapath):
    ofp = datapath.ofproto
    ofp_parser = datapath.ofproto_parser
```

```
req = ofp_parser.OFPSetConfig(datapath, ofp.OFPC_FRAG_NORMAL, 256)
datapath.send_msg(req)
```

JSON Example:

```
{
  "OFPSetConfig": {
    "flags": 0,
    "miss_send_len": 128
  }
}
```

class `ryu.ofproto.ofproto_v1_4_parser.OFPGetConfigRequest` (*datapath*)
Get config request message

The controller sends a get config request to query configuration parameters in the switch.

Example:

```
def send_get_config_request(self, datapath):
    ofp_parser = datapath.ofproto_parser

    req = ofp_parser.OFPGetConfigRequest(datapath)
    datapath.send_msg(req)
```

JSON Example:

```
{
  "OFPGetConfigRequest": {}
}
```

class `ryu.ofproto.ofproto_v1_4_parser.OFPGetConfigReply` (*datapath*, *flags=None*, *miss_send_len=None*)
Get config reply message

The switch responds to a configuration request with a get config reply message.

Attribute	Description
flags	Bitmap of the following flags. OFPC_FRAG_NORMAL OFPC_FRAG_DROP OFPC_FRAG_REASM
miss_send_len	Max bytes of new flow that datapath should send to the controller

Example:

```
@set_ev_cls(ofp_event.EventOFPGetConfigReply, MAIN_DISPATCHER)
def get_config_reply_handler(self, ev):
    msg = ev.msg
    dp = msg.datapath
    ofp = dp.ofproto
    flags = []

    if msg.flags & ofp.OFPC_FRAG_NORMAL:
        flags.append('NORMAL')
    if msg.flags & ofp.OFPC_FRAG_DROP:
        flags.append('DROP')
```

```

if msg.flags & ofp.OFPC_FRAG_REASM:
    flags.append('REASM')
self.logger.debug('OFPGetConfigReply received: '
                  'flags=%s miss_send_len=%d',
                  ','.join(flags), msg.miss_send_len)

```

JSON Example:

```

{
  "OFPGetConfigReply": {
    "flags": 0,
    "miss_send_len": 128
  }
}

```

Modify State Messages

class ryu.ofproto.ofproto_v1_4_parser.**OFPTTableMod** (*datapath, table_id, config, properties*)
Flow table configuration message

The controller sends this message to configure table state.

Attribute	Description
table_id	ID of the table (OFPTT_ALL indicates all tables)
config	Bitmap of configuration flags. OFPTC_EVICTION OFPTC_VACANCY_EVENTS
properties	List of OFPTTableModProp subclass instance

Example:

```

def send_table_mod(self, datapath):
    ofp = datapath.ofproto
    ofp_parser = datapath.ofproto_parser

    req = ofp_parser.OFPTTableMod(datapath, 1, 3)
    flags = ofp.OFPTC_VACANCY_EVENTS
    properties = [ofp_parser.OFPTTableModPropEviction(flags)]
    req = ofp_parser.OFPTTableMod(datapath, 1, 3, properties)
    datapath.send_msg(req)

```

JSON Example:

```

{
  "OFPTTableMod": {
    "config": 0,
    "properties": [
      {
        "OFPTTableModPropEviction": {
          "flags": 0,
          "length": 8,
          "type": 2
        }
      },
      {

```

```

        "OFPTableModPropVacancy": {
            "length": 8,
            "type": 3,
            "vacancy": 0,
            "vacancy_down": 0,
            "vacancy_up": 0
        }
    },
    {
        "OFPTableModPropExperimenter": {
            "data": [],
            "exp_type": 0,
            "experimenter": 101,
            "length": 12,
            "type": 65535
        }
    },
    {
        "OFPTableModPropExperimenter": {
            "data": [
                1
            ],
            "exp_type": 1,
            "experimenter": 101,
            "length": 16,
            "type": 65535
        }
    },
    {
        "OFPTableModPropExperimenter": {
            "data": [
                1,
                2
            ],
            "exp_type": 2,
            "experimenter": 101,
            "length": 20,
            "type": 65535
        }
    }
],
"table_id": 255
}
}

```

class ryu.ofproto.ofproto_v1_4_parser.**OFPFLOWMod**(datapath, cookie=0, cookie_mask=0, table_id=0, command=0, idle_timeout=0, hard_timeout=0, priority=32768, buffer_id=4294967295, out_port=0, out_group=0, flags=0, importance=0, match=None, instructions=None)

Modify Flow entry message

The controller sends this message to modify the flow table.

Attribute	Description
cookie	Opaque controller-issued identifier
cookie_mask	Mask used to restrict the cookie bits that must match when the command is <code>OFPPFC_MODIFY*</code> or <code>OFPPFC_DELETE*</code>
table_id	ID of the table to put the flow in
command	One of the following values. <code>OFPPFC_ADD</code> <code>OFPPFC_MODIFY</code> <code>OFPPFC_MODIFY_STRICT</code> <code>OFPPFC_DELETE</code> <code>OFPPFC_DELETE_STRICT</code>
idle_timeout	Idle time before discarding (seconds)
hard_timeout	Max time before discarding (seconds)
priority	Priority level of flow entry
buffer_id	Buffered packet to apply to (or <code>OFPP_NO_BUFFER</code>)
out_port	For <code>OFPPFC_DELETE*</code> commands, require matching entries to include this as an output port
out_group	For <code>OFPPFC_DELETE*</code> commands, require matching entries to include this as an output group
flags	Bitmap of the following flags. <code>OFPPFF_SEND_FLOW_REM</code> <code>OFPPFF_CHECK_OVERLAP</code> <code>OFPPFF_RESET_COUNTS</code> <code>OFPPFF_NO_PKT_COUNTS</code> <code>OFPPFF_NO_BYT_COUNTS</code>
importance	Eviction precedence
match	Instance of <code>OFPPMatch</code>
instructions	list of <code>OFPPInstruction*</code> instance

Example:

```
def send_flow_mod(self, datapath):
    ofp = datapath.ofproto
    ofp_parser = datapath.ofproto_parser

    cookie = cookie_mask = 0
    table_id = 0
    idle_timeout = hard_timeout = 0
    priority = 32768
    buffer_id = ofp.OFPP_NO_BUFFER
    importance = 0
    match = ofp_parser.OFPPMatch(in_port=1, eth_dst='ff:ff:ff:ff:ff:ff')
    actions = [ofp_parser.OFPPActionOutput(ofp.OFPP_NORMAL, 0)]
    inst = [ofp_parser.OFPPInstructionActions(ofp.OFPPIT_APPLY_ACTIONS,
                                             actions)]

    req = ofp_parser.OFPPFlowMod(datapath, cookie, cookie_mask,
                                 table_id, ofp.OFPPFC_ADD,
                                 idle_timeout, hard_timeout,
                                 priority, buffer_id,
                                 ofp.OFPP_ANY, ofp.OFPPG_ANY,
```



```

                                ofp.OFPFF_SEND_FLOW_REM,
                                importance,
                                match, inst)
datapath.send_msg(req)

```

JSON Example:

```

{
  "OFPPFlowMod": {
    "buffer_id": 65535,
    "command": 0,
    "cookie": 0,
    "cookie_mask": 0,
    "flags": 0,
    "hard_timeout": 0,
    "idle_timeout": 0,
    "importance": 0,
    "instructions": [
      {
        "OFPIInstructionActions": {
          "actions": [
            {
              "OFPAActionSetField": {
                "field": {
                  "OXMTlv": {
                    "field": "vlan_vid",
                    "mask": null,
                    "value": 258
                  }
                }
              },
              "len": 16,
              "type": 25
            },
            {
              "OFPAActionCopyTtlOut": {
                "len": 8,
                "type": 11
              }
            },
            {
              "OFPAActionCopyTtlIn": {
                "len": 8,
                "type": 12
              }
            },
            {
              "OFPAActionCopyTtlIn": {
                "len": 8,
                "type": 12
              }
            },
            {
              "OFPAActionPopPbb": {
                "len": 8,
                "type": 27
              }
            }
          ]
        }
      }
    ]
  }
}

```

```
{
  "OFPActionPushPbb": {
    "ethertype": 4660,
    "len": 8,
    "type": 26
  }
},
{
  "OFPActionPopMpls": {
    "ethertype": 39030,
    "len": 8,
    "type": 20
  }
},
{
  "OFPActionPushMpls": {
    "ethertype": 34887,
    "len": 8,
    "type": 19
  }
},
{
  "OFPActionPopVlan": {
    "len": 8,
    "type": 18
  }
},
{
  "OFPActionPushVlan": {
    "ethertype": 33024,
    "len": 8,
    "type": 17
  }
},
{
  "OFPActionDecMplsTtl": {
    "len": 8,
    "type": 16
  }
},
{
  "OFPActionSetMplsTtl": {
    "len": 8,
    "mpls_ttl": 10,
    "type": 15
  }
},
{
  "OFPActionDecNwTtl": {
    "len": 8,
    "type": 24
  }
},
{
  "OFPActionSetNwTtl": {
    "len": 8,
    "nw_ttl": 10,
    "type": 23
  }
}
```

```

    },
    {
      "OFPActionExperimenterUnknown": {
        "data": "AAECAwQFBgc=",
        "experimenter": 101,
        "len": 16,
        "type": 65535
      }
    },
    {
      "OFPActionSetQueue": {
        "len": 8,
        "queue_id": 3,
        "type": 21
      }
    },
    {
      "OFPActionGroup": {
        "group_id": 99,
        "len": 8,
        "type": 22
      }
    },
    {
      "OFPActionOutput": {
        "len": 16,
        "max_len": 65535,
        "port": 6,
        "type": 0
      }
    }
  ],
  "len": 176,
  "type": 3
}
},
{
  "OFPInstructionActions": {
    "actions": [
      {
        "OFPActionSetField": {
          "field": {
            "OXMTlv": {
              "field": "eth_src",
              "mask": null,
              "value": "01:02:03:04:05:06"
            }
          }
        },
        "len": 16,
        "type": 25
      }
    ],
    "OFPActionSetField": {
      "field": {
        "OXMTlv": {
          "field": "pbb_uca",

```

```

        "mask": null,
        "value": 1
    }
},
"len": 16,
"type": 25
}
}
],
"len": 40,
"type": 4
}
}
],
"match": {
    "OFPMatch": {
        "length": 14,
        "oxm_fields": [
            {
                "OXMTlv": {
                    "field": "eth_dst",
                    "mask": null,
                    "value": "f2:0b:a4:7d:f8:ea"
                }
            }
        ],
        "type": 1
    }
},
"out_group": 4294967295,
"out_port": 4294967295,
"priority": 123,
"table_id": 1
}
}

```

```

{
    "OFFPFlowMod": {
        "buffer_id": 65535,
        "command": 0,
        "cookie": 0,
        "cookie_mask": 0,
        "flags": 0,
        "hard_timeout": 0,
        "idle_timeout": 0,
        "importance": 0,
        "instructions": [
            {
                "OFPIInstructionGotoTable": {
                    "len": 8,
                    "table_id": 1,
                    "type": 1
                }
            }
        ],
        "match": {
            "OFPMatch": {
                "length": 22,

```

```

        "oxm_fields": [
            {
                "OXMTlv": {
                    "field": "in_port",
                    "mask": null,
                    "value": 6
                }
            },
            {
                "OXMTlv": {
                    "field": "eth_src",
                    "mask": null,
                    "value": "f2:0b:a4:7d:f8:ea"
                }
            }
        ],
        "type": 1
    }
},
"out_group": 4294967295,
"out_port": 4294967295,
"priority": 123,
"table_id": 0
}
}

```

```

{
    "OFFPFlowMod": {
        "buffer_id": 65535,
        "command": 0,
        "cookie": 0,
        "cookie_mask": 0,
        "flags": 0,
        "hard_timeout": 0,
        "idle_timeout": 0,
        "importance": 0,
        "instructions": [
            {
                "OFFPInstructionMeter": {
                    "len": 8,
                    "meter_id": 1,
                    "type": 6
                }
            },
            {
                "OFFPInstructionActions": {
                    "actions": [
                        {
                            "OFFPActionOutput": {
                                "len": 16,
                                "max_len": 65535,
                                "port": 6,
                                "type": 0
                            }
                        }
                    ]
                }
            },
            {
                "len": 24,
                "type": 3
            }
        ]
    }
}

```

```

    }
  },
  "match": {
    "OFPMatch": {
      "length": 14,
      "oxm_fields": [
        {
          "OXMTlv": {
            "field": "eth_dst",
            "mask": null,
            "value": "f2:0b:a4:7d:f8:ea"
          }
        }
      ],
      "type": 1
    }
  },
  "out_group": 4294967295,
  "out_port": 4294967295,
  "priority": 123,
  "table_id": 1
}

```

```

{
  "OFPPFlowMod": {
    "buffer_id": 65535,
    "command": 0,
    "cookie": 0,
    "cookie_mask": 0,
    "flags": 0,
    "hard_timeout": 0,
    "idle_timeout": 0,
    "importance": 0,
    "instructions": [],
    "match": {
      "OFPMatch": {
        "length": 329,
        "oxm_fields": [
          {
            "OXMTlv": {
              "field": "in_port",
              "mask": null,
              "value": 84281096
            }
          },
          {
            "OXMTlv": {
              "field": "in_phy_port",
              "mask": null,
              "value": 16909060
            }
          },
          {
            "OXMTlv": {
              "field": "metadata",
              "mask": null,

```

```

        "value": 283686952306183
    },
    {
        "OXMTlv": {
            "field": "eth_type",
            "mask": null,
            "value": 2054
        }
    },
    {
        "OXMTlv": {
            "field": "eth_dst",
            "mask": null,
            "value": "ff:ff:ff:ff:ff:ff"
        }
    },
    {
        "OXMTlv": {
            "field": "eth_src",
            "mask": null,
            "value": "f2:0b:a4:7d:f8:ea"
        }
    },
    {
        "OXMTlv": {
            "field": "vlan_vid",
            "mask": null,
            "value": 999
        }
    },
    {
        "OXMTlv": {
            "field": "ip_dscp",
            "mask": null,
            "value": 9
        }
    },
    {
        "OXMTlv": {
            "field": "ip_ecn",
            "mask": null,
            "value": 3
        }
    },
    {
        "OXMTlv": {
            "field": "ip_proto",
            "mask": null,
            "value": 99
        }
    },
    {
        "OXMTlv": {
            "field": "ipv4_src",
            "mask": null,
            "value": "1.2.3.4"
        }
    }
}

```

```
    },
    {
      "OXMTlv": {
        "field": "ipv4_dst",
        "mask": null,
        "value": "1.2.3.4"
      }
    },
    {
      "OXMTlv": {
        "field": "tcp_src",
        "mask": null,
        "value": 8080
      }
    },
    {
      "OXMTlv": {
        "field": "tcp_dst",
        "mask": null,
        "value": 18080
      }
    },
    {
      "OXMTlv": {
        "field": "udp_src",
        "mask": null,
        "value": 28080
      }
    },
    {
      "OXMTlv": {
        "field": "udp_dst",
        "mask": null,
        "value": 55936
      }
    },
    {
      "OXMTlv": {
        "field": "sctp_src",
        "mask": null,
        "value": 48080
      }
    },
    {
      "OXMTlv": {
        "field": "sctp_dst",
        "mask": null,
        "value": 59328
      }
    },
    {
      "OXMTlv": {
        "field": "icmpv4_type",
        "mask": null,
        "value": 100
      }
    },
    {

```



```

    "OXMTlv": {
      "field": "icmpv4_code",
      "mask": null,
      "value": 101
    }
  },
  {
    "OXMTlv": {
      "field": "arp_op",
      "mask": null,
      "value": 1
    }
  },
  {
    "OXMTlv": {
      "field": "arp_spa",
      "mask": null,
      "value": "10.0.0.1"
    }
  },
  {
    "OXMTlv": {
      "field": "arp_tpa",
      "mask": null,
      "value": "10.0.0.3"
    }
  },
  {
    "OXMTlv": {
      "field": "arp_sha",
      "mask": null,
      "value": "f2:0b:a4:7d:f8:ea"
    }
  },
  {
    "OXMTlv": {
      "field": "arp_tha",
      "mask": null,
      "value": "00:00:00:00:00:00"
    }
  },
  {
    "OXMTlv": {
      "field": "ipv6_src",
      "mask": null,
      "value": "fe80::f00b:a4ff:fe48:28a5"
    }
  },
  {
    "OXMTlv": {
      "field": "ipv6_dst",
      "mask": null,
      "value": "fe80::f00b:a4ff:fe05:b7dc"
    }
  },
  {
    "OXMTlv": {
      "field": "ipv6_flabel",

```

```
        "mask": null,
        "value": 541473
    },
    {
        "OXMTlv": {
            "field": "icmpv6_type",
            "mask": null,
            "value": 200
        }
    },
    {
        "OXMTlv": {
            "field": "icmpv6_code",
            "mask": null,
            "value": 201
        }
    },
    {
        "OXMTlv": {
            "field": "ipv6_nd_target",
            "mask": null,
            "value": "fe80::a60:6eff:fe7f:74e7"
        }
    },
    {
        "OXMTlv": {
            "field": "ipv6_nd_sll",
            "mask": null,
            "value": "00:00:00:00:02:9a"
        }
    },
    {
        "OXMTlv": {
            "field": "ipv6_nd_tll",
            "mask": null,
            "value": "00:00:00:00:02:2b"
        }
    },
    {
        "OXMTlv": {
            "field": "mpls_label",
            "mask": null,
            "value": 624485
        }
    },
    {
        "OXMTlv": {
            "field": "mpls_tc",
            "mask": null,
            "value": 5
        }
    },
    {
        "OXMTlv": {
            "field": "mpls_bos",
            "mask": null,
            "value": 1
        }
    }
}
```

```

    }
  },
  {
    "OXMTlv": {
      "field": "pbb_isid",
      "mask": null,
      "value": 11259375
    }
  },
  {
    "OXMTlv": {
      "field": "tunnel_id",
      "mask": null,
      "value": 651061555542690057
    }
  },
  {
    "OXMTlv": {
      "field": "ipv6_exthdr",
      "mask": null,
      "value": 500
    }
  },
  {
    "OXMTlv": {
      "field": "pbb_uca",
      "mask": null,
      "value": 1
    }
  }
],
"type": 1
},
"out_group": 4294967295,
"out_port": 4294967295,
"priority": 123,
"table_id": 1
}
}

```

class ryu.ofproto.ofproto_v1_4_parser.**OFFPGroupMod**(datapath, command=0, type_=0, group_id=0, buckets=None)

Modify group entry message

The controller sends this message to modify the group table.

Attribute	Description
command	One of the following values. OFPGC_ADD OFPGC_MODIFY OFPGC_DELETE
type	One of the following values. OFPGT_ALL OFPGT_SELECT OFPGT_INDIRECT OFPGT_FF
group_id	Group identifier
buckets	list of OFPBucket

type attribute corresponds to type_ parameter of __init__.

Example:

```
def send_group_mod(self, datapath):
    ofp = datapath.ofproto
    ofp_parser = datapath.ofproto_parser

    port = 1
    max_len = 2000
    actions = [ofp_parser.OFPActionOutput(port, max_len)]

    weight = 100
    watch_port = 0
    watch_group = 0
    buckets = [ofp_parser.OFPBucket(weight, watch_port, watch_group,
                                    actions)]

    group_id = 1
    req = ofp_parser.OFPGroupMod(datapath, ofp.OFPGC_ADD,
                                 ofp.OFPGT_SELECT, group_id, buckets)

    datapath.send_msg(req)
```

JSON Example:

```
{
  "OFPGroupMod": {
    "buckets": [
      {
        "OFPBucket": {
          "actions": [
            {
              "OFPActionOutput": {
                "len": 16,
                "max_len": 65535,
                "port": 2,
                "type": 0
              }
            }
          ]
        }
      },
      {
        "len": 32,
```

```

        "watch_group": 1,
        "watch_port": 1,
        "weight": 1
    }
}
],
"command": 0,
"group_id": 1,
"type": 0
}
}

```

```

class ryu.ofproto.ofproto_v1_4_parser.OFPPortMod (datapath, port_no=0,
                                                hw_addr='00:00:00:00:00:00',
                                                config=0, mask=0, properties=None)

```

Port modification message

The controller sends this message to modify the behavior of the port.

Attribute	Description
port_no	Port number to modify
hw_addr	The hardware address that must be the same as hw_addr of OFPPort of OFPSwitchFeatures
config	Bitmap of configuration flags. OFPPC_PORT_DOWN OFPPC_NO_RECV OFPPC_NO_FWD OFPPC_NO_PACKET_IN
mask	Bitmap of configuration flags above to be changed
properties	List of OFPPortModProp subclass instance

Example:

```

def send_port_mod(self, datapath):
    ofp = datapath.ofproto
    ofp_parser = datapath.ofproto_parser

    port_no = 3
    hw_addr = 'fa:c8:e8:76:1d:7e'
    config = 0
    mask = (ofp.OFPPC_PORT_DOWN | ofp.OFPPC_NO_RECV |
            ofp.OFPPC_NO_FWD | ofp.OFPPC_NO_PACKET_IN)
    advertise = (ofp.OFPPF_10MB_FD | ofp.OFPPF_100MB_FD |
                 ofp.OFPPF_1GB_FD | ofp.OFPPF_COPPER |
                 ofp.OFPPF_AUTONEG | ofp.OFPPF_PAUSE |
                 ofp.OFPPF_PAUSE_ASYM)
    properties = [ofp_parser.OFPPortModPropEthernet(advertise)]
    req = ofp_parser.OFPPortMod(datapath, port_no, hw_addr, config,
                                mask, properties)

    datapath.send_msg(req)

```

JSON Example:

```

{
  "OFPPortMod": {
    "config": 0,

```

```
"hw_addr": "00:11:00:00:11:11",
"mask": 0,
"port_no": 1,
"properties": [
  {
    "OFPPortModPropEthernet": {
      "advertise": 4096,
      "length": 8,
      "type": 0
    }
  },
  {
    "OFPPortModPropOptical": {
      "configure": 3,
      "fl_offset": 2000,
      "freq_lmda": 1500,
      "grid_span": 3000,
      "length": 24,
      "tx_pwr": 300,
      "type": 1
    }
  },
  {
    "OFPPortModPropExperimenter": {
      "data": [],
      "exp_type": 0,
      "experimenter": 101,
      "length": 12,
      "type": 65535
    }
  },
  {
    "OFPPortModPropExperimenter": {
      "data": [
        1
      ],
      "exp_type": 1,
      "experimenter": 101,
      "length": 16,
      "type": 65535
    }
  },
  {
    "OFPPortModPropExperimenter": {
      "data": [
        1,
        2
      ],
      "exp_type": 2,
      "experimenter": 101,
      "length": 20,
      "type": 65535
    }
  }
]
}
```

class ryu.ofproto.ofproto_v1_4_parser.**OFPMeterMod**(datapath, command=0, flags=1, meter_id=1, bands=None)

Meter modification message

The controller sends this message to modify the meter.

Attribute	Description
command	One of the following values. OFPMC_ADD OFPMC_MODIFY OFPMC_DELETE
flags	Bitmap of the following flags. OFPMF_KBPS OFPMF_PKTPS OFPMF_BURST OFPMF_STATS
meter_id	Meter instance
bands	list of the following class instance. OFPMeterBandDrop OFPMeterBandDscpRemark OFPMeterBandExperimenter

JSON Example:

```
{
  "OFPMeterMod": {
    "bands": [
      {
        "OFPMeterBandDrop": {
          "burst_size": 10,
          "len": 16,
          "rate": 1000,
          "type": 1
        }
      },
      {
        "OFPMeterBandDscpRemark": {
          "burst_size": 10,
          "len": 16,
          "prec_level": 1,
          "rate": 1000,
          "type": 2
        }
      },
      {
        "OFPMeterBandExperimenter": {
          "burst_size": 10,
          "experimenter": 999,
          "len": 16,
          "rate": 1000,
          "type": 65535
        }
      }
    ]
  }
}
```

```

        }
    },
    "command": 0,
    "flags": 14,
    "meter_id": 100
}
}

```

Multipart Messages

class ryu.ofproto.ofproto_v1_4_parser.OFPDescStatsRequest (datapath, flags=0, type_=None)

Description statistics request message

The controller uses this message to query description of the switch.

Attribute	Description
flags	Zero or OFPMPF_REQ_MORE

Example:

```

def send_desc_stats_request(self, datapath):
    ofp_parser = datapath.ofproto_parser

    req = ofp_parser.OFPDescStatsRequest(datapath, 0)
    datapath.send_msg(req)

```

JSON Example:

```

{
  "OFPDescStatsRequest": {
    "flags": 0,
    "type": 0
  }
}

```

class ryu.ofproto.ofproto_v1_4_parser.OFPDescStatsReply (datapath, type_=None, **kwargs)

Description statistics reply message

The switch responds with this message to a description statistics request.

Attribute	Description
body	Instance of OFPDescStats

Example:

```

@set_ev_cls(ofp_event.EventOFPDescStatsReply, MAIN_DISPATCHER)
def desc_stats_reply_handler(self, ev):
    body = ev.msg.body

    self.logger.debug('DescStats: mfr_desc=%s hw_desc=%s sw_desc=%s '
                      'serial_num=%s dp_desc=%s',
                      body.mfr_desc, body.hw_desc, body.sw_desc,
                      body.serial_num, body.dp_desc)

```

JSON Example:

```
{
  "OFPPDescStatsReply": {
    "body": {
      "OFPPDescStats": {
        "dp_desc": "dp",
        "hw_desc": "hw",
        "mfr_desc": "mfr",
        "serial_num": "serial",
        "sw_desc": "sw"
      }
    },
    "flags": 0,
    "type": 0
  }
}
```

```
class ryu.ofproto.ofproto_v1_4_parser.OFPFlowStatsRequest (datapath, flags=0,
                                                           table_id=255,
                                                           out_port=4294967295,
                                                           out_group=4294967295,
                                                           cookie=0, cookie_mask=0,
                                                           match=None,
                                                           type_=None)
```

Individual flow statistics request message

The controller uses this message to query individual flow statistics.

Attribute	Description
flags	Zero or OFPPMPF_REQ_MORE
table_id	ID of table to read
out_port	Require matching entries to include this as an output port
out_group	Require matching entries to include this as an output group
cookie	Require matching entries to contain this cookie value
cookie_mask	Mask used to restrict the cookie bits that must match
match	Instance of OFPMatch

Example:

```
def send_flow_stats_request(self, datapath):
    ofp = datapath.ofproto
    ofp_parser = datapath.ofproto_parser

    cookie = cookie_mask = 0
    match = ofp_parser.OFPMatch(in_port=1)
    req = ofp_parser.OFPFlowStatsRequest(datapath, 0,
                                         ofp.OFPTT_ALL,
                                         ofp.OFPP_ANY, ofp.OFPG_ANY,
                                         cookie, cookie_mask,
                                         match)

    datapath.send_msg(req)
```

JSON Example:

```
{
  "OFPFlowStatsRequest": {
    "cookie": 0,
    "cookie_mask": 0,
    "flags": 0,
    "match": {
```

```

        "OFPMatch": {
            "length": 4,
            "oxm_fields": [],
            "type": 1
        }
    },
    "out_group": 4294967295,
    "out_port": 4294967295,
    "table_id": 0,
    "type": 1
}
}

```

`class ryu.ofproto.ofproto_v1_4_parser.OFPFlowStatsReply` (*datapath*, *type_=None*, ***kwargs*)

Individual flow statistics reply message

The switch responds with this message to an individual flow statistics request.

Attribute	Description
body	List of OFPFlowStats instance

Example:

```

@set_ev_cls(ofp_event.EventOFPFlowStatsReply, MAIN_DISPATCHER)
def flow_stats_reply_handler(self, ev):
    flows = []
    for stat in ev.msg.body:
        flows.append('table_id=%s '
                    'duration_sec=%d duration_nsec=%d '
                    'priority=%d '
                    'idle_timeout=%d hard_timeout=%d flags=0x%04x '
                    'importance=%d cookie=%d packet_count=%d '
                    'byte_count=%d match=%s instructions=%s' %
                    (stat.table_id,
                     stat.duration_sec, stat.duration_nsec,
                     stat.priority,
                     stat.idle_timeout, stat.hard_timeout,
                     stat.flags, stat.importance,
                     stat.cookie, stat.packet_count, stat.byte_count,
                     stat.match, stat.instructions))
    self.logger.debug('FlowStats: %s', flows)

```

JSON Example:

```

{
  "OFPFlowStatsReply": {
    "body": [
      {
        "OFPFlowStats": {
          "byte_count": 0,
          "cookie": 0,
          "duration_nsec": 115277000,
          "duration_sec": 358,
          "flags": 0,
          "hard_timeout": 0,
          "idle_timeout": 0,
          "importance": 0,
          "instructions": [],
          "length": 56,

```

```

    "match": {
      "OFPMatch": {
        "length": 4,
        "oxm_fields": [],
        "type": 1
      }
    },
    "packet_count": 0,
    "priority": 65535,
    "table_id": 0
  }
},
{
  "OFPFLOWSTATS": {
    "byte_count": 0,
    "cookie": 0,
    "duration_nsec": 115055000,
    "duration_sec": 358,
    "flags": 0,
    "hard_timeout": 0,
    "idle_timeout": 0,
    "importance": 0,
    "instructions": [
      {
        "OFPISTRUCTIONACTIONS": {
          "actions": [
            {
              "OFPACTIONOUTPUT": {
                "len": 16,
                "max_len": 0,
                "port": 4294967290,
                "type": 0
              }
            }
          ],
          "len": 24,
          "type": 4
        }
      }
    ],
    "length": 88,
    "match": {
      "OFPMatch": {
        "length": 10,
        "oxm_fields": [
          {
            "OXMTLV": {
              "field": "eth_type",
              "mask": null,
              "value": 2054
            }
          }
        ],
        "type": 1
      }
    },
    "packet_count": 0,
    "priority": 65534,

```

```

        "table_id": 0
    }
},
{
    "OFPFlowStats": {
        "byte_count": 238,
        "cookie": 0,
        "duration_nsec": 511582000,
        "duration_sec": 316220,
        "flags": 0,
        "hard_timeout": 0,
        "idle_timeout": 0,
        "importance": 0,
        "instructions": [
            {
                "OFPInstructionGotoTable": {
                    "len": 8,
                    "table_id": 1,
                    "type": 1
                }
            }
        ],
        "length": 80,
        "match": {
            "OFPMatch": {
                "length": 22,
                "oxm_fields": [
                    {
                        "OXMTlv": {
                            "field": "in_port",
                            "mask": null,
                            "value": 6
                        }
                    },
                    {
                        "OXMTlv": {
                            "field": "eth_src",
                            "mask": null,
                            "value": "f2:0b:a4:7d:f8:ea"
                        }
                    }
                ]
            },
            "type": 1
        }
    },
    "packet_count": 3,
    "priority": 123,
    "table_id": 0
}
},
{
    "OFPFlowStats": {
        "byte_count": 98,
        "cookie": 0,
        "duration_nsec": 980901000,
        "duration_sec": 313499,
        "flags": 0,
        "hard_timeout": 0,

```

```

"idle_timeout": 0,
"importance": 0,
"instructions": [
  {
    "OFPInstructionActions": {
      "actions": [
        {
          "OFPActionSetField": {
            "field": {
              "OXMTlv": {
                "field": "vlan_vid",
                "mask": null,
                "value": 258
              }
            }
          },
          "len": 16,
          "type": 25
        },
        {
          "OFPActionCopyTtlOut": {
            "len": 8,
            "type": 11
          }
        },
        {
          "OFPActionCopyTtlIn": {
            "len": 8,
            "type": 12
          }
        },
        {
          "OFPActionCopyTtlIn": {
            "len": 8,
            "type": 12
          }
        },
        {
          "OFPActionPopPbb": {
            "len": 8,
            "type": 27
          }
        },
        {
          "OFPActionPushPbb": {
            "ethertype": 4660,
            "len": 8,
            "type": 26
          }
        },
        {
          "OFPActionPopMpls": {
            "ethertype": 39030,
            "len": 8,
            "type": 20
          }
        }
      ]
    }
  }
]

```

```
    "OFPActionPushMpls": {
      "ethertype": 34887,
      "len": 8,
      "type": 19
    }
  },
  {
    "OFPActionPopVlan": {
      "len": 8,
      "type": 18
    }
  },
  {
    "OFPActionPushVlan": {
      "ethertype": 33024,
      "len": 8,
      "type": 17
    }
  },
  {
    "OFPActionDecMplsTtl": {
      "len": 8,
      "type": 16
    }
  },
  {
    "OFPActionSetMplsTtl": {
      "len": 8,
      "mpls_ttl": 10,
      "type": 15
    }
  },
  {
    "OFPActionDecNwTtl": {
      "len": 8,
      "type": 24
    }
  },
  {
    "OFPActionSetNwTtl": {
      "len": 8,
      "nw_ttl": 10,
      "type": 23
    }
  },
  {
    "OFPActionSetQueue": {
      "len": 8,
      "queue_id": 3,
      "type": 21
    }
  },
  {
    "OFPActionGroup": {
      "group_id": 99,
      "len": 8,
      "type": 22
    }
  }
}
```

```

    },
    {
      "OFPACTIONOutput": {
        "len": 16,
        "max_len": 65535,
        "port": 6,
        "type": 0
      }
    },
    {
      "OFPACTIONExperimenterUnknown": {
        "len": 16,
        "data": "ZXhwX2RhdGE=",
        "experimenter": 98765432,
        "type": 65535
      }
    },
    {
      "NXACTIONUnknown": {
        "len": 16,
        "data": "cF9kYXRh",
        "experimenter": 8992,
        "type": 65535,
        "subtype": 25976
      }
    }
  ],
  "len": 192,
  "type": 3
}
},
{
  "OFPISTRUCTIONActions": {
    "actions": [
      {
        "OFPACTIONSetField": {
          "field": {
            "OXMTlv": {
              "field": "eth_src",
              "mask": null,
              "value": "01:02:03:04:05:06"
            }
          }
        },
        "len": 16,
        "type": 25
      }
    ],
    {
      "OFPACTIONSetField": {
        "field": {
          "OXMTlv": {
            "field": "pbb_uca",
            "mask": null,
            "value": 1
          }
        }
      },
      "len": 16,
      "type": 25
    }
  }
}

```

```

        }
    ],
    "len": 40,
    "type": 4
}
},
{
    "OFPIInstructionActions": {
        "actions": [
            {
                "OFPAActionOutput": {
                    "len": 16,
                    "max_len": 65535,
                    "port": 4294967293,
                    "type": 0
                }
            }
        ],
        "len": 24,
        "type": 3
    }
}
],
"length": 312,
"match": {
    "OFPMatch": {
        "length": 4,
        "oxm_fields": [],
        "type": 1
    }
},
"packet_count": 1,
"priority": 0,
"table_id": 0
}
}
],
"flags": 0,
"type": 1
}
}

```

```

class ryu.ofproto.ofproto_v1_4_parser.OFPAggregateStatsRequest (datapath, flags,
                                                                table_id, out_port,
                                                                out_group, cookie,
                                                                cookie_mask,
                                                                match,
                                                                type_=None)

```

Aggregate flow statistics request message

The controller uses this message to query aggregate flow statistics.

Attribute	Description
flags	Zero or OFPMPF_REQ_MORE
table_id	ID of table to read
out_port	Require matching entries to include this as an output port
out_group	Require matching entries to include this as an output group
cookie	Require matching entries to contain this cookie value
cookie_mask	Mask used to restrict the cookie bits that must match
match	Instance of OFPMatch

Example:

```
def send_aggregate_stats_request(self, datapath):
    ofp = datapath.ofproto
    ofp_parser = datapath.ofproto_parser

    cookie = cookie_mask = 0
    match = ofp_parser.OFPMatch(in_port=1)
    req = ofp_parser.OFPAggregateStatsRequest(datapath, 0,
                                              ofp.OFPTT_ALL,
                                              ofp.OFPP_ANY,
                                              ofp.OFPG_ANY,
                                              cookie, cookie_mask,
                                              match)

    datapath.send_msg(req)
```

JSON Example:

```
{
  "OFPAggregateStatsRequest": {
    "cookie": 0,
    "cookie_mask": 0,
    "flags": 0,
    "match": {
      "OFPMatch": {
        "length": 4,
        "oxm_fields": [],
        "type": 1
      }
    },
    "out_group": 4294967295,
    "out_port": 4294967295,
    "table_id": 255,
    "type": 2
  }
}
```

class ryu.ofproto.ofproto_v1_4_parser.**OFPAggregateStatsReply** (*datapath*, *type_=None*, ***kwargs*)

Aggregate flow statistics reply message

The switch responds with this message to an aggregate flow statistics request.

Attribute	Description
body	Instance of OFPAggregateStats

Example:

```
@set_ev_cls(ofp_event.EventOFPAggregateStatsReply, MAIN_DISPATCHER)
def aggregate_stats_reply_handler(self, ev):
    body = ev.msg.body
```

```
self.logger.debug('AggregateStats: packet_count=%d byte_count=%d '
                  'flow_count=%d',
                  body.packet_count, body.byte_count,
                  body.flow_count)
```

JSON Example:

```
{
  "OFPAggregateStatsReply": {
    "body": {
      "OFPAggregateStats": {
        "byte_count": 574,
        "flow_count": 6,
        "packet_count": 7
      }
    },
    "flags": 0,
    "type": 2
  }
}
```

class ryu.ofproto.ofproto_v1_4_parser.**OFPTableStatsRequest** (*datapath*, *flags*, *type_=None*)

Table statistics request message

The controller uses this message to query flow table statistics.

Attribute	Description
flags	Zero or OFPMPF_REQ_MORE

Example:

```
def send_table_stats_request(self, datapath):
    ofp_parser = datapath.ofproto_parser

    req = ofp_parser.OFPTableStatsRequest(datapath, 0)
    datapath.send_msg(req)
```

JSON Example:

```
{
  "OFPTableStatsRequest": {
    "flags": 0,
    "type": 3
  }
}
```

class ryu.ofproto.ofproto_v1_4_parser.**OFPTableStatsReply** (*datapath*, *type_=None*, ***kwargs*)

Table statistics reply message

The switch responds with this message to a table statistics request.

Attribute	Description
body	List of OFPTableStats instance

Example:

```
@set_ev_cls(ofp_event.EventOFPTableStatsReply, MAIN_DISPATCHER)
def table_stats_reply_handler(self, ev):
    tables = []
```

```

for stat in ev.msg.body:
    tables.append('table_id=%d active_count=%d lookup_count=%d '
                  ' matched_count=%d' %
                  (stat.table_id, stat.active_count,
                   stat.lookup_count, stat.matched_count))
self.logger.debug('TableStats: %s', tables)

```

JSON Example:

```

{
  "OFPTableStatsReply": {
    "body": [
      {
        "OFPTableStats": {
          "active_count": 4,
          "lookup_count": 4,
          "matched_count": 4,
          "table_id": 0
        }
      },
      {
        "OFPTableStats": {
          "active_count": 4,
          "lookup_count": 4,
          "matched_count": 4,
          "table_id": 1
        }
      }
    ],
    "flags": 0,
    "type": 3
  }
}

```

class ryu.ofproto.ofproto_v1_4_parser.**OFPTableDescStatsRequest** (*datapath*, *flags=0*, *type=None*)

Table description request message

The controller uses this message to query description of all the tables.

Attribute	Description
flags	Zero or OFPMPF_REQ_MORE

Example:

```

def send_table_desc_stats_request(self, datapath):
    ofp_parser = datapath.ofproto_parser

    req = ofp_parser.OFPTableDescStatsRequest(datapath, 0)
    datapath.send_msg(req)

```

JSON Example:

```

{
  "OFPTableDescStatsRequest": {
    "flags": 0,
    "type": 14
  }
}

```

```
class ryu.ofproto.ofproto_v1_4_parser.OFPTableDescStatsReply (datapath, type_=None,
                                                             **kwargs)
```

Table description reply message

The switch responds with this message to a table description request.

Attribute	Description
body	List of OFPTableDesc instance

Example:

```
@set_ev_cls(ofp_event.EventOFPTableDescStatsReply, MAIN_DISPATCHER)
def table_desc_stats_reply_handler(self, ev):
    tables = []
    for p in ev.msg.body:
        tables.append('table_id=%d config=0x%08x properties=%s' %
                     (p.table_id, p.config, repr(p.properties)))
    self.logger.debug('OFPTableDescStatsReply received: %s', tables)
```

JSON Example:

```
{
  "OFPTableDescStatsReply": {
    "body": [
      {
        "OFPTableDesc": {
          "config": 0,
          "length": 24,
          "properties": [
            {
              "OFPTableModPropExperimenter": {
                "data": [],
                "exp_type": 0,
                "experimenter": 101,
                "length": 12,
                "type": 65535
              }
            }
          ],
          "table_id": 7
        }
      },
      {
        "OFPTableDesc": {
          "config": 0,
          "length": 80,
          "properties": [
            {
              "OFPTableModPropEviction": {
                "flags": 0,
                "length": 8,
                "type": 2
              }
            }
          ],
          {
            "OFPTableModPropVacancy": {
              "length": 8,
              "type": 3,
              "vacancy": 0,
              "vacancy_down": 0,
            }
          }
        }
      }
    ]
  }
}
```

```

        "vacancy_up": 0
    },
    {
        "OFPTableModPropExperimenter": {
            "data": [],
            "exp_type": 0,
            "experimenter": 101,
            "length": 12,
            "type": 65535
        }
    },
    {
        "OFPTableModPropExperimenter": {
            "data": [
                1
            ],
            "exp_type": 1,
            "experimenter": 101,
            "length": 16,
            "type": 65535
        }
    },
    {
        "OFPTableModPropExperimenter": {
            "data": [
                1,
                2
            ],
            "exp_type": 2,
            "experimenter": 101,
            "length": 20,
            "type": 65535
        }
    }
],
"table_id": 8
}
},
"flags": 0,
"type": 14
}
}

```

class ryu.ofproto.ofproto_v1_4_parser.**OFPTableFeaturesStatsRequest** (*datapath*,
flags=0,
body=None,
type_=None)

Table features statistics request message

The controller uses this message to query table features.

Attribute	Description
body	List of OFPTableFeaturesStats instances. The default is [].

JSON Example:

See an example in:

ryu/tests/unit/ofproto/json/of14/5-53-ofp_table_features_request.packet.json

```
class ryu.ofproto.ofproto_v1_4_parser.OFPTableFeaturesStatsReply (datapath,
                                                                type_=None,
                                                                **kwargs)
```

Table features statistics reply message

The switch responds with this message to a table features statistics request.

Attribute	Description
body	List of OFPTableFeaturesStats instance

JSON Example:

See an example in:

ryu/tests/unit/ofproto/json/of14/5-54-ofp_table_features_reply.packet.json

```
class ryu.ofproto.ofproto_v1_4_parser.OFPPortStatsRequest (datapath, flags, port_no,
                                                           type_=None)
```

Port statistics request message

The controller uses this message to query information about ports statistics.

Attribute	Description
flags	Zero or OFPMPF_REQ_MORE
port_no	Port number to read (OFPP_ANY to all ports)

Example:

```
def send_port_stats_request(self, datapath):
    ofp = datapath.ofproto
    ofp_parser = datapath.ofproto_parser

    req = ofp_parser.OFPPortStatsRequest(datapath, 0, ofp.OFPP_ANY)
    datapath.send_msg(req)
```

JSON Example:

```
{
  "OFPPortStatsRequest": {
    "flags": 0,
    "port_no": 4294967295,
    "type": 4
  }
}
```

```
class ryu.ofproto.ofproto_v1_4_parser.OFPPortStatsReply (datapath,
                                                         type_=None,
                                                         **kwargs)
```

Port statistics reply message

The switch responds with this message to a port statistics request.

Attribute	Description
body	List of OFPPortStats instance

Example:

```
@set_ev_cls(ofp_event.EventOFPPortStatsReply, MAIN_DISPATCHER)
def port_stats_reply_handler(self, ev):
    ports = []
    for stat in ev.msg.body:
        ports.append(stat.length, stat.port_no,
                    stat.duration_sec, stat.duration_nsec,
```

```

        stat.rx_packets, stat.tx_packets,
        stat.rx_bytes, stat.tx_bytes,
        stat.rx_dropped, stat.tx_dropped,
        stat.rx_errors, stat.tx_errors,
        repr(stat.properties))
self.logger.debug('PortStats: %s', ports)

```

JSON Example:

```

{
  "OFPPortStatsReply": {
    "body": [
      {
        "OFPPortStats": {
          "duration_nsec": 0,
          "duration_sec": 0,
          "length": 224,
          "port_no": 7,
          "properties": [
            {
              "OFPPortStatsPropEthernet": {
                "collisions": 0,
                "length": 40,
                "rx_crc_err": 0,
                "rx_frame_err": 0,
                "rx_over_err": 0,
                "type": 0
              }
            },
            {
              "OFPPortStatsPropOptical": {
                "bias_current": 300,
                "flags": 3,
                "length": 44,
                "rx_freq_lmda": 1500,
                "rx_grid_span": 500,
                "rx_offset": 700,
                "rx_pwr": 2000,
                "temperature": 273,
                "tx_freq_lmda": 1500,
                "tx_grid_span": 500,
                "tx_offset": 700,
                "tx_pwr": 2000,
                "type": 1
              }
            },
            {
              "OFPPortStatsPropExperimenter": {
                "data": [],
                "exp_type": 0,
                "experimenter": 101,
                "length": 12,
                "type": 65535
              }
            },
            {
              "OFPPortStatsPropExperimenter": {
                "data": [

```

```

        1
        ],
        "exp_type": 1,
        "experimenter": 101,
        "length": 16,
        "type": 65535
    }
},
{
    "OFPPortStatsPropExperimenter": {
        "data": [
            1,
            2
        ],
        "exp_type": 2,
        "experimenter": 101,
        "length": 20,
        "type": 65535
    }
}
],
"rx_bytes": 0,
"rx_dropped": 0,
"rx_errors": 0,
"rx_packets": 0,
"tx_bytes": 336,
"tx_dropped": 0,
"tx_errors": 0,
"tx_packets": 4
}
},
{
    "OFPPortStats": {
        "duration_nsec": 0,
        "duration_sec": 0,
        "length": 120,
        "port_no": 6,
        "properties": [
            {
                "OFPPortStatsPropEthernet": {
                    "collisions": 0,
                    "length": 40,
                    "rx_crc_err": 0,
                    "rx_frame_err": 0,
                    "rx_over_err": 0,
                    "type": 0
                }
            }
        ],
        "rx_bytes": 336,
        "rx_dropped": 0,
        "rx_errors": 0,
        "rx_packets": 4,
        "tx_bytes": 336,
        "tx_dropped": 0,
        "tx_errors": 0,
        "tx_packets": 4
    }
}

```



```

    }
    ],
    "flags": 0,
    "type": 4
  }
}

```

class ryu.ofproto.ofproto_v1_4_parser.**OFPPortDescStatsRequest** (*datapath*, *flags=0*, *type=None*)

Port description request message

The controller uses this message to query description of all the ports.

Attribute	Description
flags	Zero or OFPMPF_REQ_MORE

Example:

```

def send_port_desc_stats_request(self, datapath):
    ofp_parser = datapath.ofproto_parser

    req = ofp_parser.OFPPortDescStatsRequest(datapath, 0)
    datapath.send_msg(req)

```

JSON Example:

```

{
  "OFPPortDescStatsRequest": {
    "flags": 0,
    "type": 13
  }
}

```

class ryu.ofproto.ofproto_v1_4_parser.**OFPPortDescStatsReply** (*datapath*, *type=None*, ***kwargs*)

Port description reply message

The switch responds with this message to a port description request.

Attribute	Description
body	List of OFPPort instance

Example:

```

@set_ev_cls(ofp_event.EventOFPPortDescStatsReply, MAIN_DISPATCHER)
def port_desc_stats_reply_handler(self, ev):
    ports = []
    for p in ev.msg.body:
        ports.append('port_no=%d hw_addr=%s name=%s config=0x%08x '
                    'state=0x%08x properties=%s' %
                    (p.port_no, p.hw_addr,
                     p.name, p.config, p.state, repr(p.properties)))
    self.logger.debug('OFPPortDescStatsReply received: %s', ports)

```

JSON Example:

```

{
  "OFPPortDescStatsReply": {
    "body": [
      {
        "OFPPort": {

```

```

"config": 0,
"hw_addr": "f2:0b:a4:d0:3f:70",
"length": 168,
"name": "Port7",
"port_no": 7,
"properties": [
  {
    "OFPPortDescPropEthernet": {
      "advertised": 10240,
      "curr": 10248,
      "curr_speed": 5000,
      "length": 32,
      "max_speed": 5000,
      "peer": 10248,
      "supported": 10248,
      "type": 0
    }
  },
  {
    "OFPPortDescPropOptical": {
      "length": 40,
      "rx_grid_freq_lmda": 1500,
      "rx_max_freq_lmda": 2000,
      "rx_min_freq_lmda": 1000,
      "supported": 1,
      "tx_grid_freq_lmda": 1500,
      "tx_max_freq_lmda": 2000,
      "tx_min_freq_lmda": 1000,
      "tx_pwr_max": 2000,
      "tx_pwr_min": 1000,
      "type": 1
    }
  },
  {
    "OFPPortDescPropExperimenter": {
      "data": [],
      "exp_type": 0,
      "experimenter": 101,
      "length": 12,
      "type": 65535
    }
  },
  {
    "OFPPortDescPropExperimenter": {
      "data": [
        1
      ],
      "exp_type": 1,
      "experimenter": 101,
      "length": 16,
      "type": 65535
    }
  },
  {
    "OFPPortDescPropExperimenter": {
      "data": [
        1,
        2
      ]
    }
  }
]

```

```

        ],
        "exp_type": 2,
        "experimenter": 101,
        "length": 20,
        "type": 65535
    }
}
],
"state": 4
}
},
{
    "OFPPort": {
        "config": 0,
        "hw_addr": "f2:0b:a4:7d:f8:ea",
        "length": 72,
        "name": "Port6",
        "port_no": 6,
        "properties": [
            {
                "OFPPortDescPropEthernet": {
                    "advertised": 10240,
                    "curr": 10248,
                    "curr_speed": 5000,
                    "length": 32,
                    "max_speed": 5000,
                    "peer": 10248,
                    "supported": 10248,
                    "type": 0
                }
            }
        ],
        "state": 4
    }
}
],
"flags": 0,
"type": 13
}
}

```

```

class ryu.ofproto.ofproto_v1_4_parser.OFPQueueStatsRequest (datapath, flags=0,
                                                             port_no=4294967295,
                                                             queue_id=4294967295,
                                                             type_=None)

```

Queue statistics request message

The controller uses this message to query queue statistics.

Attribute	Description
flags	Zero or OFPMPF_REQ_MORE
port_no	Port number to read
queue_id	ID of queue to read

Example:

```

def send_queue_stats_request(self, datapath):
    ofp = datapath.ofproto
    ofp_parser = datapath.ofproto_parser

```

```
req = ofp_parser.OFPQueueStatsRequest(datapath, 0, ofp.OFPP_ANY,
                                      ofp.OFPQ_ALL)
datapath.send_msg(req)
```

JSON Example:

```
{
  "OFPQueueStatsRequest": {
    "flags": 0,
    "port_no": 4294967295,
    "queue_id": 4294967295,
    "type": 5
  }
}
```

```
class ryu.ofproto.ofproto_v1_4_parser.OFPQueueStatsReply(datapath, type_=None,
                                                         **kwargs)
```

Queue statistics reply message

The switch responds with this message to an aggregate flow statistics request.

Attribute	Description
body	List of OFPQueueStats instance

Example:

```
@set_ev_cls(ofp_event.EventOFPQueueStatsReply, MAIN_DISPATCHER)
def queue_stats_reply_handler(self, ev):
    queues = []
    for stat in ev.msg.body:
        queues.append('port_no=%d queue_id=%d '
                    'tx_bytes=%d tx_packets=%d tx_errors=%d '
                    'duration_sec=%d duration_nsec=%d'
                    'properties=%s' %
                    (stat.port_no, stat.queue_id,
                     stat.tx_bytes, stat.tx_packets, stat.tx_errors,
                     stat.duration_sec, stat.duration_nsec,
                     repr(stat.properties)))
    self.logger.debug('QueueStats: %s', queues)
```

JSON Example:

```
{
  "OFPQueueStatsReply": {
    "body": [
      {
        "OFPQueueStats": {
          "duration_nsec": 0,
          "duration_sec": 0,
          "length": 104,
          "port_no": 7,
          "properties": [
            {
              "OFPQueueStatsPropExperimenter": {
                "data": [],
                "exp_type": 0,
                "experimenter": 101,
                "length": 12,
                "type": 65535
              }
            }
          ]
        }
      }
    ]
  }
}
```

```

    },
    {
      "OFPQueueStatsPropExperimenter": {
        "data": [
          1
        ],
        "exp_type": 1,
        "experimenter": 101,
        "length": 16,
        "type": 65535
      }
    },
    {
      "OFPQueueStatsPropExperimenter": {
        "data": [
          1,
          2
        ],
        "exp_type": 2,
        "experimenter": 101,
        "length": 20,
        "type": 65535
      }
    }
  ],
  "queue_id": 1,
  "tx_bytes": 0,
  "tx_errors": 0,
  "tx_packets": 0
}
},
{
  "OFPQueueStats": {
    "duration_nsec": 0,
    "duration_sec": 0,
    "length": 48,
    "port_no": 6,
    "properties": [],
    "queue_id": 1,
    "tx_bytes": 0,
    "tx_errors": 0,
    "tx_packets": 0
  }
},
{
  "OFPQueueStats": {
    "duration_nsec": 0,
    "duration_sec": 0,
    "length": 48,
    "port_no": 7,
    "properties": [],
    "queue_id": 2,
    "tx_bytes": 0,
    "tx_errors": 0,
    "tx_packets": 0
  }
}
],

```

```

        "flags": 0,
        "type": 5
    }
}

```

class ryu.ofproto.ofproto_v1_4_parser.**OFFPQueueDescStatsRequest** (*datapath*, *flags=0*, *port_no=4294967295*, *queue_id=4294967295*, *type_=None*)

Queue description request message

The controller uses this message to query description of all the queues.

Attribute	Description
flags	Zero or OFFPMPF_REQ_MORE
port_no	Port number to read (OFFP_ANY for all ports)
queue_id	ID of queue to read (OFFPQ_ALL for all queues)

Example:

```

def send_queue_desc_stats_request(self, datapath):
    ofp = datapath.ofproto
    ofp_parser = datapath.ofproto_parser
    req = ofp_parser.OFFPQueueDescStatsRequest(datapath, 0,
                                                ofp.OFFP_ANY,
                                                ofp.OFFPQ_ALL)

    datapath.send_msg(req)

```

JSON Example:

```

{
  "OFFPQueueDescStatsRequest": {
    "flags": 0,
    "port_no": 7,
    "queue_id": 4294967295,
    "type": 15
  }
}

```

class ryu.ofproto.ofproto_v1_4_parser.**OFFPQueueDescStatsReply** (*datapath*, *type_=None*, ***kwargs*)

Queue description reply message

The switch responds with this message to a queue description request.

Attribute	Description
body	List of OFFPQueueDesc instance

Example:

```

@set_ev_cls(ofp_event.EventOFFPQueueDescStatsReply, MAIN_DISPATCHER)
def queue_desc_stats_reply_handler(self, ev):
    queues = []
    for q in ev.msg.body:
        queues.append('port_no=%d queue_id=0x%08x properties=%s' %
                    (q.port_no, q.queue_id, repr(q.properties)))
    self.logger.debug('OFFPQueueDescStatsReply received: %s', queues)

```

JSON Example:

```

{
  "OFPPQueueDescStatsReply": {
    "body": [
      {
        "OFPPQueueDesc": {
          "len": 32,
          "port_no": 7,
          "properties": [
            {
              "OFPPQueueDescPropExperimenter": {
                "data": [],
                "exp_type": 0,
                "experimenter": 101,
                "length": 12,
                "type": 65535
              }
            }
          ],
          "queue_id": 0
        }
      },
      {
        "OFPPQueueDesc": {
          "len": 88,
          "port_no": 8,
          "properties": [
            {
              "OFPPQueueDescPropMinRate": {
                "length": 8,
                "rate": 300,
                "type": 1
              }
            },
            {
              "OFPPQueueDescPropMaxRate": {
                "length": 8,
                "rate": 900,
                "type": 2
              }
            },
            {
              "OFPPQueueDescPropExperimenter": {
                "data": [],
                "exp_type": 0,
                "experimenter": 101,
                "length": 12,
                "type": 65535
              }
            }
          ],
          "queue_id": 0
        }
      },
      {
        "OFPPQueueDesc": {
          "len": 16,
          "port_no": 9,
          "properties": [
            {
              "OFPPQueueDescPropExperimenter": {
                "data": [
                  1
                ],
                "exp_type": 1,
                "experimenter": 101,
                "length": 16,
                "type": 65535
              }
            }
          ],
          "queue_id": 0
        }
      }
    ]
  }
}

```

```

    }
  },
  {
    "OFPPQueueDescPropExperimenter": {
      "data": [
        1,
        2
      ],
      "exp_type": 2,
      "experimenter": 101,
      "length": 20,
      "type": 65535
    }
  }
],
"queue_id": 1
}
}
"flags": 0,
"type": 15
}
}

```

class ryu.ofproto.ofproto_v1_4_parser.OFPPGroupStatsRequest (datapath, flags=0, group_id=4294967292, type_=None)

Group statistics request message

The controller uses this message to query statistics of one or more groups.

Attribute	Description
flags	Zero or OFPPMPF_REQ_MORE
group_id	ID of group to read (OFPPG_ALL to all groups)

Example:

```

def send_group_stats_request(self, datapath):
    ofp = datapath.ofproto
    ofp_parser = datapath.ofproto_parser

    req = ofp_parser.OFPPGroupStatsRequest(datapath, 0, ofp.OFPPG_ALL)
    datapath.send_msg(req)

```

JSON Example:

```

{
  "OFPPGroupStatsRequest": {
    "flags": 0,
    "group_id": 4294967292,
    "type": 6
  }
}

```

class ryu.ofproto.ofproto_v1_4_parser.OFPPGroupStatsReply (datapath, type_=None, **kwargs)

Group statistics reply message

The switch responds with this message to a group statistics request.

Attribute	Description
body	List of OFPGroupStats instance

Example:

```
@set_ev_cls(ofp_event.EventOFPGroupStatsReply, MAIN_DISPATCHER)
def group_stats_reply_handler(self, ev):
    groups = []
    for stat in ev.msg.body:
        groups.append('length=%d group_id=%d '
                     'ref_count=%d packet_count=%d byte_count=%d '
                     'duration_sec=%d duration_nsec=%d' %
                     (stat.length, stat.group_id,
                      stat.ref_count, stat.packet_count,
                      stat.byte_count, stat.duration_sec,
                      stat.duration_nsec))
    self.logger.debug('GroupStats: %s', groups)
```

JSON Example:

```
{
  "OFPGroupStatsReply": {
    "body": [
      {
        "OFPGroupStats": {
          "bucket_stats": [
            {
              "OFPBucketCounter": {
                "byte_count": 2345,
                "packet_count": 234
              }
            }
          ],
          "byte_count": 12345,
          "duration_nsec": 609036000,
          "duration_sec": 9,
          "group_id": 1,
          "length": 56,
          "packet_count": 123,
          "ref_count": 2
        }
      }
    ],
    "flags": 0,
    "type": 6
  }
}
```

class ryu.ofproto.ofproto_v1_4_parser.OFPGroupDescStatsRequest (*datapath*, *flags=0*, *type_=None*)

Group description request message

The controller uses this message to list the set of groups on a switch.

Attribute	Description
flags	Zero or OFPMPF_REQ_MORE

Example:

```
def send_group_desc_stats_request(self, datapath):
    ofp = datapath.ofproto
```

```

ofp_parser = datapath.ofproto_parser

req = ofp_parser.OFPGroupDescStatsRequest(datapath, 0)
datapath.send_msg(req)

```

JSON Example:

```

{
  "OFPGroupDescStatsRequest": {
    "flags": 0,
    "type": 7
  }
}

```

class ryu.ofproto.ofproto_v1_4_parser.OFPGroupDescStatsReply (*datapath, type_=None, **kwargs*)

Group description reply message

The switch responds with this message to a group description request.

Attribute	Description
body	List of OFPGroupDescStats instance

Example:

```

@set_ev_cls(ofp_event.EventOFPGroupDescStatsReply, MAIN_DISPATCHER)
def group_desc_stats_reply_handler(self, ev):
    desc = []
    for stat in ev.msg.body:
        desc.append('length=%d type=%d group_id=%d '
                   'buckets=%s' %
                   (stat.length, stat.type, stat.group_id,
                    stat.bucket))
    self.logger.debug('GroupDescStats: %s', desc)

```

JSON Example:

```

{
  "OFPGroupDescStatsReply": {
    "body": [
      {
        "OFPGroupDescStats": {
          "buckets": [
            {
              "OFPBucket": {
                "actions": [
                  {
                    "OFPActionOutput": {
                      "len": 16,
                      "max_len": 65535,
                      "port": 2,
                      "type": 0
                    }
                  }
                ]
              }
            }
          ],
          "len": 32,
          "watch_group": 1,
          "watch_port": 1,
          "weight": 1
        }
      ]
    }
  }
}

```

```

        }
        ],
        "group_id": 1,
        "length": 40,
        "type": 0
    }
}
],
"flags": 0,
"type": 7
}
}

```

class ryu.ofproto.ofproto_v1_4_parser.OFPGroupFeaturesStatsRequest (datapath, flags=0, type=None)

Group features request message

The controller uses this message to list the capabilities of groups on a switch.

Attribute	Description
flags	Zero or OFPMPF_REQ_MORE

Example:

```

def send_group_features_stats_request(self, datapath):
    ofp_parser = datapath.ofproto_parser

    req = ofp_parser.OFPGroupFeaturesStatsRequest(datapath, 0)
    datapath.send_msg(req)

```

JSON Example:

```

{
  "OFPGroupFeaturesStatsRequest": {
    "flags": 0,
    "type": 8
  }
}

```

class ryu.ofproto.ofproto_v1_4_parser.OFPGroupFeaturesStatsReply (datapath, type=None, **kwargs)

Group features reply message

The switch responds with this message to a group features request.

Attribute	Description
body	Instance of OFPGroupFeaturesStats

Example:

```

@set_ev_cls(ofp_event.EventOFPGroupFeaturesStatsReply, MAIN_DISPATCHER)
def group_features_stats_reply_handler(self, ev):
    body = ev.msg.body

    self.logger.debug('GroupFeaturesStats: types=%d '
                      'capabilities=0x%08x max_groups=%s '
                      'actions=%s',
                      body.types, body.capabilities,
                      body.max_groups, body.actions)

```

JSON Example:

```
{
  "OFPGroupFeaturesStatsReply": {
    "body": {
      "OFPGroupFeaturesStats": {
        "actions": [
          67082241,
          67082241,
          67082241,
          67082241
        ],
        "capabilities": 5,
        "max_groups": [
          16777216,
          16777216,
          16777216,
          16777216
        ],
        "types": 15
      }
    },
    "flags": 0,
    "type": 8
  }
}
```

class ryu.ofproto.ofproto_v1_4_parser.OFPMeterStatsRequest (datapath, flags=0, meter_id=4294967295, type_=None)

Meter statistics request message

The controller uses this message to query statistics for one or more meters.

Attribute	Description
flags	Zero or OFPMPF_REQ_MORE
meter_id	ID of meter to read (OFPM_ALL to all meters)

Example:

```
def send_meter_stats_request(self, datapath):
    ofp = datapath.ofproto
    ofp_parser = datapath.ofproto_parser

    req = ofp_parser.OFPMeterStatsRequest(datapath, 0, ofp.OFPM_ALL)
    datapath.send_msg(req)
```

JSON Example:

```
{
  "OFPMeterStatsRequest": {
    "flags": 0,
    "meter_id": 4294967295,
    "type": 9
  }
}
```

class ryu.ofproto.ofproto_v1_4_parser.OFPMeterStatsReply (datapath, type_=None, **kwargs)

Meter statistics reply message

The switch responds with this message to a meter statistics request.

Attribute	Description
body	List of OFPMeterStats instance

Example:

```
@set_ev_cls(ofp_event.EventOFPMeterStatsReply, MAIN_DISPATCHER)
def meter_stats_reply_handler(self, ev):
    meters = []
    for stat in ev.msg.body:
        meters.append('meter_id=0x%08x len=%d flow_count=%d '
                    'packet_in_count=%d byte_in_count=%d '
                    'duration_sec=%d duration_nsec=%d '
                    'band_stats=%s' %
                    (stat.meter_id, stat.len, stat.flow_count,
                     stat.packet_in_count, stat.byte_in_count,
                     stat.duration_sec, stat.duration_nsec,
                     stat.band_stats))
    self.logger.debug('MeterStats: %s', meters)
```

JSON Example:

```
{
  "OFPMeterStatsReply": {
    "body": [
      {
        "OFPMeterStats": {
          "band_stats": [
            {
              "OFPMeterBandStats": {
                "byte_band_count": 0,
                "packet_band_count": 0
              }
            }
          ],
          "byte_in_count": 0,
          "duration_nsec": 480000,
          "duration_sec": 0,
          "flow_count": 0,
          "len": 56,
          "meter_id": 100,
          "packet_in_count": 0
        }
      }
    ],
    "flags": 0,
    "type": 9
  }
}
```

```
class ryu.ofproto.ofproto_v1_4_parser.OFPMeterConfigStatsRequest (datapath,
                                                                    flags=0, meter_id=4294967295,
                                                                    type_=None)
```

Meter configuration statistics request message

The controller uses this message to query configuration for one or more meters.

Attribute	Description
flags	Zero or OFPMPF_REQ_MORE
meter_id	ID of meter to read (OFPM_ALL to all meters)

Example:

```
def send_meter_config_stats_request(self, datapath):
    ofp = datapath.ofproto
    ofp_parser = datapath.ofproto_parser

    req = ofp_parser.OFPMeterConfigStatsRequest(datapath, 0,
                                                  ofp.OFPM_ALL)

    datapath.send_msg(req)
```

JSON Example:

```
{
  "OFPMeterConfigStatsRequest": {
    "flags": 0,
    "meter_id": 4294967295,
    "type": 10
  }
}
```

```
class ryu.ofproto.ofproto_v1_4_parser.OFPMeterConfigStatsReply(datapath,
                                                                type=None,
                                                                **kwargs)
```

Meter configuration statistics reply message

The switch responds with this message to a meter configuration statistics request.

Attribute	Description
body	List of OFPMeterConfigStats instance

Example:

```
@set_ev_cls(ofp_event.EventOFPMeterConfigStatsReply, MAIN_DISPATCHER)
def meter_config_stats_reply_handler(self, ev):
    configs = []
    for stat in ev.msg.body:
        configs.append('length=%d flags=0x%04x meter_id=0x%08x '
                      'bands=%s' %
                      (stat.length, stat.flags, stat.meter_id,
                       stat.bands))
    self.logger.debug('MeterConfigStats: %s', configs)
```

JSON Example:

```
{
  "OFPMeterConfigStatsReply": {
    "body": [
      {
        "OFPMeterConfigStats": {
          "bands": [
            {
              "OFPMeterBandDrop": {
                "burst_size": 10,
                "len": 16,
                "rate": 1000,
                "type": 1
              }
            }
          ]
        }
      }
    ]
  }
}
```

```

        }
        ],
        "flags": 14,
        "length": 24,
        "meter_id": 100
    }
}
],
"flags": 0,
"type": 10
}
}

```

class ryu.ofproto.ofproto_v1_4_parser.OFPMeterFeaturesStatsRequest (datapath, flags=0, type=None)

Meter features statistics request message

The controller uses this message to query the set of features of the metering subsystem.

Attribute	Description
flags	Zero or OFPMPF_REQ_MORE

Example:

```

def send_meter_features_stats_request(self, datapath):
    ofp_parser = datapath.ofproto_parser

    req = ofp_parser.OFPMeterFeaturesStatsRequest(datapath, 0)
    datapath.send_msg(req)

```

JSON Example:

```

{
  "OFPMeterFeaturesStatsRequest": {
    "flags": 0,
    "type": 11
  }
}

```

class ryu.ofproto.ofproto_v1_4_parser.OFPMeterFeaturesStatsReply (datapath, type=None, **kwargs)

Meter features statistics reply message

The switch responds with this message to a meter features statistics request.

Attribute	Description
body	List of OFPMeterFeaturesStats instance

Example:

```

@set_ev_cls(ofp_event.EventOFPMeterFeaturesStatsReply, MAIN_DISPATCHER)
def meter_features_stats_reply_handler(self, ev):
    features = []
    for stat in ev.msg.body:
        features.append('max_meter=%d band_types=0x%08x '
                       'capabilities=0x%08x max_bands=%d '
                       'max_color=%d' %
                       (stat.max_meter, stat.band_types,
                        stat.capabilities, stat.max_bands,

```

```

        stat.max_color))
    self.logger.debug('MeterFeaturesStats: %s', features)

```

JSON Example:

```

{
  "OFPMeterFeaturesStatsReply": {
    "body": [
      {
        "OFPMeterFeaturesStats": {
          "band_types": 2147483654,
          "capabilities": 15,
          "max_bands": 255,
          "max_color": 0,
          "max_meter": 16777216
        }
      }
    ],
    "flags": 0,
    "type": 11
  }
}

```

```

class ryu.ofproto.ofproto_v1_4_parser.OFPFlowMonitorRequest (datapath,
                                                             flags=0,
                                                             monitor_id=0,
                                                             out_port=4294967295,
                                                             out_group=4294967295,
                                                             monitor_flags=0,
                                                             table_id=255,
                                                             command=0,
                                                             match=None,
                                                             type_=None)

```

Flow monitor request message

The controller uses this message to query flow monitors.

Attribute	Description
flags	Zero or OFPMPF_REQ_MORE
monitor_id	Controller-assigned ID for this monitor
out_port	Require matching entries to include this as an output port
out_group	Require matching entries to include this as an output group
monitor_flags	Bitmap of the following flags. OFPFMF_INITIAL OFPFMF_ADD OFPFMF_REMOVED OFPFMF_MODIFY OFPFMF_INSTRUCTIONS OFPFMF_NO_ABBREV OFPFMF_ONLY_OWN
table_id	ID of table to monitor
command	One of the following values. OFPFMC_ADD OFPFMC_MODIFY OFPFMC_DELETE
match	Instance of OFPMatch

Example:

```
def send_flow_monitor_request(self, datapath):
    ofp = datapath.ofproto
    ofp_parser = datapath.ofproto_parser

    monitor_flags = [ofp.OFPFMF_INITIAL, ofp.OFPFMF_ONLY_OWN]
    match = ofp_parser.OFPMatch(in_port=1)
    req = ofp_parser.OFPFlowMonitorRequest(datapath, 0, 10000,
                                           ofp.OFPF_ANY, ofp.OFPF_ANY,
                                           monitor_flags,
                                           ofp.OFPPTT_ALL,
                                           ofp.OFPFMC_ADD, match)

    datapath.send_msg(req)
```

JSON Example:

```
{
  "OFPFlowMonitorRequest": {
    "command": 0,
    "flags": 0,
    "match": {
      "OFPMatch": {
        "length": 14,
        "oxm_fields": [
          {
            "OXMTlv": {
              "field": "eth_dst",
              "mask": null,
              "value": "f2:0b:a4:7d:f8:ea"
            }
          }
        ]
      }
    }
  }
}
```

```

        }
    ],
    "type": 1
}
},
"monitor_flags": 15,
"monitor_id": 100000000,
"out_group": 4294967295,
"out_port": 22,
"table_id": 33,
"type": 16
}
}

```

class ryu.ofproto.ofproto_v1_4_parser.**OFPPFlowMonitorReply** (*datapath*, *type_=None*, ***kwargs*)

Flow monitor reply message

The switch responds with this message to a flow monitor request.

Attribute	Description
body	List of list of the following class instance. OFPPFlowMonitorFull OFPPFlowMonitorAbbrev OFPPFlowMonitorPaused

Example:

```

@set_ev_cls(ofp_event.EventOFPPFlowMonitorReply, MAIN_DISPATCHER)
def flow_monitor_reply_handler(self, ev):
    msg = ev.msg
    dp = msg.datapath
    ofp = dp.ofproto
    flow_updates = []

    for update in msg.body:
        update_str = 'length=%d event=%d' %
            (update.length, update.event)
        if (update.event == ofp.OFPFME_INITIAL or
            update.event == ofp.OFPFME_ADDED or
            update.event == ofp.OFPFME_REMOVED or
            update.event == ofp.OFPFME_MODIFIED):
            update_str += 'table_id=%d reason=%d idle_timeout=%d '
                'hard_timeout=%d priority=%d cookie=%d '
                'match=%d instructions=%s' %
                (update.table_id, update.reason,
                 update.idle_timeout, update.hard_timeout,
                 update.priority, update.cookie,
                 update.match, update.instructions)
        elif update.event == ofp.OFPFME_ABBREV:
            update_str += 'xid=%d' % (update.xid)
        flow_updates.append(update_str)
    self.logger.debug('FlowUpdates: %s', flow_updates)

```

JSON Example:

```

{
  "OFPPFlowMonitorReply": {
    "body": [
      {
        "OFPPFlowUpdateFull": {
          "cookie": 0,
          "event": 0,
          "hard_timeout": 700,
          "idle_timeout": 600,
          "instructions": [
            {
              "OFPIInstructionActions": {
                "actions": [
                  {
                    "OFPAActionOutput": {
                      "len": 16,
                      "max_len": 0,
                      "port": 4294967290,
                      "type": 0
                    }
                  }
                ],
                "len": 24,
                "type": 4
              }
            }
          ],
          "length": 64,
          "match": {
            "OFPMatch": {
              "length": 10,
              "oxm_fields": [
                {
                  "OXMTlv": {
                    "field": "eth_type",
                    "mask": null,
                    "value": 2054
                  }
                }
              ],
              "type": 1
            }
          },
          "priority": 3,
          "reason": 0,
          "table_id": 0
        }
      },
      {
        "OFPPFlowUpdateAbbrev": {
          "event": 4,
          "length": 8,
          "xid": 1234
        }
      },
      {
        "OFPPFlowUpdatePaused": {
          "event": 5,

```

```

        "length": 8
    }
}
1,
"flags": 0,
"type": 16
}
}

```

class ryu.ofproto.ofproto_v1_4_parser.**OFPExperimenterStatsRequest** (*datapath, flags, experimenter, exp_type, data, type_=None*)

Experimenter multipart request message

Attribute	Description
flags	Zero or OFPMPF_REQ_MORE
experimenter	Experimenter ID
exp_type	Experimenter defined
data	Experimenter defined additional data

JSON Example:

```

{
  "OFPExperimenterStatsRequest": {
    "data": "aG9nZWhvZ2U=",
    "exp_type": 3405678728,
    "experimenter": 3735928495,
    "flags": 0,
    "type": 65535
  }
}

```

class ryu.ofproto.ofproto_v1_4_parser.**OFPExperimenterStatsReply** (*datapath, type_=None, **kwargs*)

Experimenter multipart reply message

Attribute	Description
body	An OFPExperimenterMultipart instance

JSON Example:

```

{
  "OFPExperimenterStatsReply": {
    "body": {
      "OFPExperimenterMultipart": {
        "data": "dGVzdGRhdGE5OTk5OTk5OQ==",
        "exp_type": 3405674359,
        "experimenter": 3735928495
      }
    },
    "flags": 0,
    "type": 65535
  }
}

```

Packet-Out Message

```
class ryu.ofproto.ofproto_v1_4_parser.OFPPacketOut (datapath,          buffer_id=None,
                                                in_port=None,        actions=None,
                                                data=None, actions_len=None)
```

Packet-Out message

The controller uses this message to send a packet out through the switch.

Attribute	Description
buffer_id	ID assigned by datapath (OFPP_NO_BUFFER if none)
in_port	Packet's input port or OFPP_CONTROLLER
actions	list of OpenFlow action class
data	Packet data

Example:

```
def send_packet_out(self, datapath, buffer_id, in_port):
    ofp = datapath.ofproto
    ofp_parser = datapath.ofproto_parser

    actions = [ofp_parser.OFPActionOutput(ofp.OFPP_FLOOD, 0)]
    req = ofp_parser.OFPPacketOut(datapath, buffer_id,
                                  in_port, actions)

    datapath.send_msg(req)
```

JSON Example:

```
{
  "OFPPacketOut": {
    "actions": [
      {
        "OFPActionOutput": {
          "len": 16,
          "max_len": 65535,
          "port": 4294967292,
          "type": 0
        }
      }
    ],
    "actions_len": 16,
    "buffer_id": 4294967295,
    "data": "8guk0D9w8gukffjqCABFAABU+BoAAP8Br4sKAAABCgAAAggAAgj3YAAAMdYCAAAAAACrjS0xAAAAABARE",
    "in_port": 4294967293
  }
}
```

Barrier Message

```
class ryu.ofproto.ofproto_v1_4_parser.OFPBarrierRequest (datapath)
Barrier request message
```

The controller sends this message to ensure message dependencies have been met or receive notifications for completed operations.

Example:

```
def send_barrier_request(self, datapath):
    ofp_parser = datapath.ofproto_parser

    req = ofp_parser.OFPBarrierRequest(datapath)
    datapath.send_msg(req)
```

JSON Example:

```
{
  "OFPBarrierRequest": {}
}
```

class ryu.ofproto.ofproto_v1_4_parser.OFPBarrierReply(*datapath*)
Barrier reply message

The switch responds with this message to a barrier request.

Example:

```
@set_ev_cls(ofp_event.EventOFPBarrierReply, MAIN_DISPATCHER)
def barrier_reply_handler(self, ev):
    self.logger.debug('OFPBarrierReply received')
```

JSON Example:

```
{
  "OFPBarrierReply": {}
}
```

Role Request Message

class ryu.ofproto.ofproto_v1_4_parser.OFPRoleRequest(*datapath*, *role=None*, *generation_id=None*)

Role request message

The controller uses this message to change its role.

Attribute	Description
role	One of the following values. OFPCR_ROLE_NOCHANGE OFPCR_ROLE_EQUAL OFPCR_ROLE_MASTER OFPCR_ROLE_SLAVE
generation_id	Master Election Generation ID

Example:

```
def send_role_request(self, datapath):
    ofp = datapath.ofproto
    ofp_parser = datapath.ofproto_parser

    req = ofp_parser.OFPRoleRequest(datapath, ofp.OFPCR_ROLE_EQUAL, 0)
    datapath.send_msg(req)
```

JSON Example:

```
{
  "OFPPRoleRequest": {
    "generation_id": 17294086455919964160,
    "role": 2
  }
}
```

class ryu.ofproto.ofproto_v1_4_parser.**OFPPRoleReply**(datapath, role=None, generation_id=None)

Role reply message

The switch responds with this message to a role request.

Attribute	Description
role	One of the following values. OFPPCR_ROLE_NOCHANGE OFPPCR_ROLE_EQUAL OFPPCR_ROLE_MASTER OFPPCR_ROLE_SLAVE
generation_id	Master Election Generation ID

Example:

```
@set_ev_cls(ofp_event.EventOFPPRoleReply, MAIN_DISPATCHER)
def role_reply_handler(self, ev):
    msg = ev.msg
    dp = msg.datapath
    ofp = dp.ofproto

    if msg.role == ofp.OFPPCR_ROLE_NOCHANGE:
        role = 'NOCHANGE'
    elif msg.role == ofp.OFPPCR_ROLE_EQUAL:
        role = 'EQUAL'
    elif msg.role == ofp.OFPPCR_ROLE_MASTER:
        role = 'MASTER'
    elif msg.role == ofp.OFPPCR_ROLE_SLAVE:
        role = 'SLAVE'
    else:
        role = 'unknown'

    self.logger.debug('OFPPRoleReply received: '
                      'role=%s generation_id=%d',
                      role, msg.generation_id)
```

JSON Example:

```
{
  "OFPPRoleReply": {
    "generation_id": 17294086455919964160,
    "role": 3
  }
}
```

Bundle Messages

`class ryu.ofproto.ofproto_v1_4_parser.OFPBundleCtrlMsg` (*datapath, bundle_id, type_, flags, properties*)

Bundle control message

The controller uses this message to create, destroy and commit bundles

Attribute	Description
bundle_id	Id of the bundle
type	One of the following values. OFPBCT_OPEN_REQUEST OFPBCT_OPEN_REPLY OFPBCT_CLOSE_REQUEST OFPBCT_CLOSE_REPLY OFPBCT_COMMIT_REQUEST OFPBCT_COMMIT_REPLY OFPBCT_DISCARD_REQUEST OFPBCT_DISCARD_REPLY
flags	Bitmap of the following flags. OFPBF_ATOMIC OFPBF_ORDERED
properties	List of OFPBundleProp subclass instance

Example:

```
def send_bundle_control(self, datapath):
    ofp = datapath.ofproto
    ofp_parser = datapath.ofproto_parser

    req = ofp_parser.OFPBundleCtrlMsg(datapath, 7,
                                      ofp.OFPBCT_OPEN_REQUEST,
                                      [ofp.OFPBF_ATOMIC], [])

    datapath.send_msg(req)
```

JSON Example:

```
{
  "OFPBundleCtrlMsg": {
    "bundle_id": 1234,
    "flags": 1,
    "properties": [
      {
        "OFPBundlePropExperimenter": {
          "data": [],
          "exp_type": 0,
          "experimenter": 101,
          "length": 12,
          "type": 65535
        }
      },
      {
        "OFPBundlePropExperimenter": {
```



```

        "data": [
            1
        ],
        "exp_type": 1,
        "experimenter": 101,
        "length": 16,
        "type": 65535
    }
},
{
    "OFPPBundlePropExperimenter": {
        "data": [
            1,
            2
        ],
        "exp_type": 2,
        "experimenter": 101,
        "length": 20,
        "type": 65535
    }
}
],
"type": 0
}
}

```

class ryu.ofproto.ofproto_v1_4_parser.OFPBundleAddMsg (datapath, bundle_id, flags, message, properties)

Bundle control message

The controller uses this message to create, destroy and commit bundles

Attribute	Description
bundle_id	Id of the bundle
flags	Bitmap of the following flags. OFPBF_ATOMIC OFPBF_ORDERED
message	MsgBase subclass instance
properties	List of OFPBundleProp subclass instance

Example:

```

def send_bundle_add_message(self, datapath):
    ofp = datapath.ofproto
    ofp_parser = datapath.ofproto_parser

    msg = ofp_parser.OFPRoleRequest(datapath, ofp.OFPCR_ROLE_EQUAL, 0)

    req = ofp_parser.OFPBundleAddMsg(datapath, 7, [ofp.OFPBF_ATOMIC],
                                     msg, [])

    datapath.send_msg(req)

```

JSON Example:

```

{
  "OFPPBundleAddMsg": {
    "bundle_id": 1234,

```

```

    "flags": 1,
    "message": {
      "OFPEchoRequest": {
        "data": null
      }
    },
    "properties": [
      {
        "OFPBundlePropExperimenter": {
          "data": [],
          "exp_type": 0,
          "experimenter": 101,
          "length": 12,
          "type": 65535
        }
      },
      {
        "OFPBundlePropExperimenter": {
          "data": [
            1
          ],
          "exp_type": 1,
          "experimenter": 101,
          "length": 16,
          "type": 65535
        }
      },
      {
        "OFPBundlePropExperimenter": {
          "data": [
            1,
            2
          ],
          "exp_type": 2,
          "experimenter": 101,
          "length": 20,
          "type": 65535
        }
      }
    ]
  }
}

```

Set Asynchronous Configuration Message

class ryu.ofproto.ofproto_v1_4_parser.**OFPSetAsync** (*datapath*, *properties=None*)

Set asynchronous configuration message

The controller sends this message to set the asynchronous messages that it wants to receive on a given OpenFlow channel.

Attribute	Description
properties	List of OFPAsyncConfigProp subclass instances

Example:

```

def send_set_async(self, datapath):
    ofp = datapath.ofproto

```

```

ofp_parser = datapath.ofproto_parser

properties = [ofp_parser.OFPAsyncConfigPropReasons(
    8, ofp_parser.OFPACPT_PACKET_IN_SLAVE,
    (ofp_parser.OFPR_APPLY_ACTION |
     ofp_parser.OFPR_INVALID_TTL)),
    ofp_parser.OFPAsyncConfigPropExperimenter(
    ofp.OFPTFPT_EXPERIMENTER_MASTER,
    16, 100, 2, bytearray())]
req = ofp_parser.OFPSetAsync(datapath, properties)
datapath.send_msg(req)

```

JSON Example:

```

{
  "OFPSetAsync": {
    "properties": [
      {
        "OFPAsyncConfigPropReasons": {
          "length": 8,
          "mask": 3,
          "type": 0
        }
      },
      {
        "OFPAsyncConfigPropReasons": {
          "length": 8,
          "mask": 3,
          "type": 1
        }
      },
      {
        "OFPAsyncConfigPropReasons": {
          "length": 8,
          "mask": 3,
          "type": 2
        }
      },
      {
        "OFPAsyncConfigPropReasons": {
          "length": 8,
          "mask": 3,
          "type": 3
        }
      },
      {
        "OFPAsyncConfigPropReasons": {
          "length": 8,
          "mask": 3,
          "type": 4
        }
      },
      {
        "OFPAsyncConfigPropReasons": {
          "length": 8,
          "mask": 3,
          "type": 5
        }
      }
    ]
  }
}

```

```
    },
    {
      "OFPAsyncConfigPropReasons": {
        "length": 8,
        "mask": 3,
        "type": 6
      }
    },
    {
      "OFPAsyncConfigPropReasons": {
        "length": 8,
        "mask": 3,
        "type": 7
      }
    },
    {
      "OFPAsyncConfigPropReasons": {
        "length": 8,
        "mask": 24,
        "type": 8
      }
    },
    {
      "OFPAsyncConfigPropReasons": {
        "length": 8,
        "mask": 24,
        "type": 9
      }
    },
    {
      "OFPAsyncConfigPropReasons": {
        "length": 8,
        "mask": 3,
        "type": 10
      }
    },
    {
      "OFPAsyncConfigPropReasons": {
        "length": 8,
        "mask": 3,
        "type": 11
      }
    },
    {
      "OFPAsyncConfigPropExperimenter": {
        "data": [],
        "exp_type": 0,
        "experimenter": 101,
        "length": 12,
        "type": 65534
      }
    },
    {
      "OFPAsyncConfigPropExperimenter": {
        "data": [
          1
        ],
        "exp_type": 1,

```

```

        "experimenter": 101,
        "length": 16,
        "type": 65535
    },
    {
        "OFPPAsyncConfigPropExperimenter": {
            "data": [
                1,
                2
            ],
            "exp_type": 2,
            "experimenter": 101,
            "length": 20,
            "type": 65535
        }
    }
]
}

```

class ryu.ofproto.ofproto_v1_4_parser.OFPGetAsyncRequest (datapath)
Get asynchronous configuration request message

The controller uses this message to query the asynchronous message.

Example:

```

def send_get_async_request(self, datapath):
    ofp_parser = datapath.ofproto_parser

    req = ofp_parser.OFPGetAsyncRequest(datapath)
    datapath.send_msg(req)

```

JSON Example:

```

{
  "OFPGetAsyncRequest": {}
}

```

class ryu.ofproto.ofproto_v1_4_parser.OFPGetAsyncReply (datapath, properties=None)
Get asynchronous configuration reply message

The switch responds with this message to a get asynchronous configuration request.

Attribute	Description
properties	List of OFPPAsyncConfigProp subclass instances

Example:

```

@set_ev_cls(ofp_event.EventOFPGetAsyncReply, MAIN_DISPATCHER)
def get_async_reply_handler(self, ev):
    msg = ev.msg

    self.logger.debug('OFPGetAsyncReply received: '
                      'properties=%s', repr(msg.properties))

```

JSON Example:

```

{
  "OFPGetAsyncReply": {

```

```
"properties": [  
  {  
    "OFPAsyncConfigPropReasons": {  
      "length": 8,  
      "mask": 3,  
      "type": 0  
    }  
  },  
  {  
    "OFPAsyncConfigPropReasons": {  
      "length": 8,  
      "mask": 3,  
      "type": 1  
    }  
  },  
  {  
    "OFPAsyncConfigPropReasons": {  
      "length": 8,  
      "mask": 3,  
      "type": 2  
    }  
  },  
  {  
    "OFPAsyncConfigPropReasons": {  
      "length": 8,  
      "mask": 3,  
      "type": 3  
    }  
  },  
  {  
    "OFPAsyncConfigPropReasons": {  
      "length": 8,  
      "mask": 3,  
      "type": 4  
    }  
  },  
  {  
    "OFPAsyncConfigPropReasons": {  
      "length": 8,  
      "mask": 3,  
      "type": 5  
    }  
  },  
  {  
    "OFPAsyncConfigPropReasons": {  
      "length": 8,  
      "mask": 3,  
      "type": 6  
    }  
  },  
  {  
    "OFPAsyncConfigPropReasons": {  
      "length": 8,  
      "mask": 3,  
      "type": 7  
    }  
  },  
  {  
    "OFPAsyncConfigPropReasons": {  
      "length": 8,  
      "mask": 3,  
      "type": 8  
    }  
  }  
]
```

```

    "OFPAsyncConfigPropReasons": {
        "length": 8,
        "mask": 24,
        "type": 8
    }
},
{
    "OFPAsyncConfigPropReasons": {
        "length": 8,
        "mask": 24,
        "type": 9
    }
},
{
    "OFPAsyncConfigPropReasons": {
        "length": 8,
        "mask": 3,
        "type": 10
    }
},
{
    "OFPAsyncConfigPropReasons": {
        "length": 8,
        "mask": 3,
        "type": 11
    }
},
{
    "OFPAsyncConfigPropExperimenter": {
        "data": [],
        "exp_type": 0,
        "experimenter": 101,
        "length": 12,
        "type": 65534
    }
},
{
    "OFPAsyncConfigPropExperimenter": {
        "data": [
            1
        ],
        "exp_type": 1,
        "experimenter": 101,
        "length": 16,
        "type": 65535
    }
},
{
    "OFPAsyncConfigPropExperimenter": {
        "data": [
            1,
            2
        ],
        "exp_type": 2,
        "experimenter": 101,
        "length": 20,
        "type": 65535
    }
}

```

```

    }
  ]
}
}

```

Asynchronous Messages

Packet-In Message

```

class ryu.ofproto.ofproto_v1_4_parser.OFPPacketIn (datapath, buffer_id=None, total_len=None, reason=None, table_id=None, cookie=None, match=None, data=None)

```

Packet-In message

The switch sends the packet that received to the controller by this message.

Attribute	Description
buffer_id	ID assigned by datapath
total_len	Full length of frame
reason	Reason packet is being sent. OFPR_TABLE_MISS OFPR_APPLY_ACTION OFPR_INVALID_TTL OFPR_ACTION_SET OFPR_GROUP OFPR_PACKET_OUT
table_id	ID of the table that was looked up
cookie	Cookie of the flow entry that was looked up
match	Instance of OFPMatch
data	Ethernet frame

Example:

```

@set_ev_cls(ofp_event.EventOFPPacketIn, MAIN_DISPATCHER)
def packet_in_handler(self, ev):
    msg = ev.msg
    dp = msg.datapath
    ofp = dp.ofproto

    if msg.reason == ofp.TABLE_MISS:
        reason = 'TABLE MISS'
    elif msg.reason == ofp.OFPR_APPLY_ACTION:
        reason = 'APPLY ACTION'
    elif msg.reason == ofp.OFPR_INVALID_TTL:
        reason = 'INVALID TTL'
    elif msg.reason == ofp.OFPR_ACTION_SET:
        reason = 'ACTION SET'
    elif msg.reason == ofp.OFPR_GROUP:
        reason = 'GROUP'
    elif msg.reason == ofp.OFPR_PACKET_OUT:
        reason = 'PACKET OUT'
    else:

```



```

reason = 'unknown'

self.logger.debug('OFPPacketIn received: '
                  'buffer_id=%x total_len=%d reason=%s '
                  'table_id=%d cookie=%d match=%s data=%s',
                  msg.buffer_id, msg.total_len, reason,
                  msg.table_id, msg.cookie, msg.match,
                  utils.hex_array(msg.data))

```

JSON Example:

```

{
  "OFPPacketIn": {
    "buffer_id": 2,
    "cookie": 2836868884868096,
    "data": "/////////8gukffjqCAYAAQgABgQAAfILpH346goAAAEAAAAAAAAAKAAAD",
    "match": {
      "OFPMatch": {
        "length": 80,
        "oxm_fields": [
          {
            "OXMTlv": {
              "field": "in_port",
              "mask": null,
              "value": 6
            }
          },
          {
            "OXMTlv": {
              "field": "eth_type",
              "mask": null,
              "value": 2054
            }
          },
          {
            "OXMTlv": {
              "field": "eth_dst",
              "mask": null,
              "value": "ff:ff:ff:ff:ff:ff"
            }
          },
          {
            "OXMTlv": {
              "field": "eth_src",
              "mask": null,
              "value": "f2:0b:a4:7d:f8:ea"
            }
          },
          {
            "OXMTlv": {
              "field": "arp_op",
              "mask": null,
              "value": 1
            }
          },
          {
            "OXMTlv": {
              "field": "arp_spa",

```

```

        "mask": null,
        "value": "10.0.0.1"
    }
},
{
    "OXMTlv": {
        "field": "arp_tpa",
        "mask": null,
        "value": "10.0.0.3"
    }
},
{
    "OXMTlv": {
        "field": "arp_sha",
        "mask": null,
        "value": "f2:0b:a4:7d:f8:ea"
    }
},
{
    "OXMTlv": {
        "field": "arp_tha",
        "mask": null,
        "value": "00:00:00:00:00:00"
    }
}
],
"type": 1
}
},
"reason": 3,
"table_id": 1,
"total_len": 42
}
}

```

```

{
    "OFPPacketIn": {
        "buffer_id": 4026531840,
        "cookie": 2836868884868096,
        "data": "",
        "match": {
            "OFPMatch": {
                "length": 329,
                "oxm_fields": [
                    {
                        "OXMTlv": {
                            "field": "in_port",
                            "mask": null,
                            "value": 84281096
                        }
                    },
                    {
                        "OXMTlv": {
                            "field": "in_phy_port",
                            "mask": null,
                            "value": 16909060
                        }
                    }
                ]
            }
        }
    }
}

```

```

{
  "OXMTlv": {
    "field": "metadata",
    "mask": null,
    "value": 283686952306183
  }
},
{
  "OXMTlv": {
    "field": "eth_type",
    "mask": null,
    "value": 2054
  }
},
{
  "OXMTlv": {
    "field": "eth_dst",
    "mask": null,
    "value": "ff:ff:ff:ff:ff:ff"
  }
},
{
  "OXMTlv": {
    "field": "eth_src",
    "mask": null,
    "value": "f2:0b:a4:7d:f8:ea"
  }
},
{
  "OXMTlv": {
    "field": "vlan_vid",
    "mask": null,
    "value": 999
  }
},
{
  "OXMTlv": {
    "field": "ip_dscp",
    "mask": null,
    "value": 9
  }
},
{
  "OXMTlv": {
    "field": "ip_ecn",
    "mask": null,
    "value": 3
  }
},
{
  "OXMTlv": {
    "field": "ip_proto",
    "mask": null,
    "value": 99
  }
},
{
  "OXMTlv": {

```

```
        "field": "ipv4_src",
        "mask": null,
        "value": "1.2.3.4"
    }
},
{
    "OXMTlv": {
        "field": "ipv4_dst",
        "mask": null,
        "value": "1.2.3.4"
    }
},
{
    "OXMTlv": {
        "field": "tcp_src",
        "mask": null,
        "value": 8080
    }
},
{
    "OXMTlv": {
        "field": "tcp_dst",
        "mask": null,
        "value": 18080
    }
},
{
    "OXMTlv": {
        "field": "udp_src",
        "mask": null,
        "value": 28080
    }
},
{
    "OXMTlv": {
        "field": "udp_dst",
        "mask": null,
        "value": 55936
    }
},
{
    "OXMTlv": {
        "field": "sctp_src",
        "mask": null,
        "value": 48080
    }
},
{
    "OXMTlv": {
        "field": "sctp_dst",
        "mask": null,
        "value": 59328
    }
},
{
    "OXMTlv": {
        "field": "icmpv4_type",
        "mask": null,
```

```

        "value": 100
    },
    {
        "OXMTlv": {
            "field": "icmpv4_code",
            "mask": null,
            "value": 101
        }
    },
    {
        "OXMTlv": {
            "field": "arp_op",
            "mask": null,
            "value": 1
        }
    },
    {
        "OXMTlv": {
            "field": "arp_spa",
            "mask": null,
            "value": "10.0.0.1"
        }
    },
    {
        "OXMTlv": {
            "field": "arp_tpa",
            "mask": null,
            "value": "10.0.0.3"
        }
    },
    {
        "OXMTlv": {
            "field": "arp_sha",
            "mask": null,
            "value": "f2:0b:a4:7d:f8:ea"
        }
    },
    {
        "OXMTlv": {
            "field": "arp_tha",
            "mask": null,
            "value": "00:00:00:00:00:00"
        }
    },
    {
        "OXMTlv": {
            "field": "ipv6_src",
            "mask": null,
            "value": "fe80::f00b:a4ff:fe48:28a5"
        }
    },
    {
        "OXMTlv": {
            "field": "ipv6_dst",
            "mask": null,
            "value": "fe80::f00b:a4ff:fe05:b7dc"
        }
    }
}

```

```
    },
    {
      "OXMTlv": {
        "field": "ipv6_flabel",
        "mask": null,
        "value": 541473
      }
    },
    {
      "OXMTlv": {
        "field": "icmpv6_type",
        "mask": null,
        "value": 200
      }
    },
    {
      "OXMTlv": {
        "field": "icmpv6_code",
        "mask": null,
        "value": 201
      }
    },
    {
      "OXMTlv": {
        "field": "ipv6_nd_target",
        "mask": null,
        "value": "fe80::a60:6eff:fe7f:74e7"
      }
    },
    {
      "OXMTlv": {
        "field": "ipv6_nd_sll",
        "mask": null,
        "value": "00:00:00:00:02:9a"
      }
    },
    {
      "OXMTlv": {
        "field": "ipv6_nd_tll",
        "mask": null,
        "value": "00:00:00:00:02:2b"
      }
    },
    {
      "OXMTlv": {
        "field": "mpls_label",
        "mask": null,
        "value": 624485
      }
    },
    {
      "OXMTlv": {
        "field": "mpls_tc",
        "mask": null,
        "value": 5
      }
    },
    {
```

```

        "OXMTlv": {
            "field": "mpls_bos",
            "mask": null,
            "value": 1
        }
    },
    {
        "OXMTlv": {
            "field": "pbb_isid",
            "mask": null,
            "value": 11259375
        }
    },
    {
        "OXMTlv": {
            "field": "tunnel_id",
            "mask": null,
            "value": 651061555542690057
        }
    },
    {
        "OXMTlv": {
            "field": "ipv6_exthdr",
            "mask": null,
            "value": 500
        }
    },
    {
        "OXMTlv": {
            "field": "pbb_uca",
            "mask": null,
            "value": 1
        }
    }
],
"type": 1
}
},
"reason": 0,
"table_id": 200,
"total_len": 0
}
}

```

Flow Removed Message

```

class ryu.ofproto.ofproto_v1_4_parser.OFPFlowRemoved(datapath, cookie=None, priority=None, reason=None, table_id=None, duration_sec=None, duration_nsec=None, idle_timeout=None, hard_timeout=None, packet_count=None, byte_count=None, match=None)

```

Flow removed message

When flow entries time out or are deleted, the switch notifies controller with this message.

Attribute	Description
cookie	Opaque controller-issued identifier
priority	Priority level of flow entry
reason	One of the following values. OFPRR_IDLE_TIMEOUT OFPRR_HARD_TIMEOUT OFPRR_DELETE OFPRR_GROUP_DELETE OFPRR_METER_DELETE OFPRR_EVICTION
table_id	ID of the table
duration_sec	Time flow was alive in seconds
duration_nsec	Time flow was alive in nanoseconds beyond duration_sec
idle_timeout	Idle timeout from original flow mod
hard_timeout	Hard timeout from original flow mod
packet_count	Number of packets that was associated with the flow
byte_count	Number of bytes that was associated with the flow
match	Instance of OFPMatch

Example:

```
@set_ev_cls(ofp_event.EventOFPPFlowRemoved, MAIN_DISPATCHER)
def flow_removed_handler(self, ev):
    msg = ev.msg
    dp = msg.datapath
    ofp = dp.ofproto

    if msg.reason == ofp.OFPRR_IDLE_TIMEOUT:
        reason = 'IDLE TIMEOUT'
    elif msg.reason == ofp.OFPRR_HARD_TIMEOUT:
        reason = 'HARD TIMEOUT'
    elif msg.reason == ofp.OFPRR_DELETE:
        reason = 'DELETE'
    elif msg.reason == ofp.OFPRR_GROUP_DELETE:
        reason = 'GROUP DELETE'
    else:
        reason = 'unknown'

    self.logger.debug('OFPPFlowRemoved received: '
                      'cookie=%d priority=%d reason=%s table_id=%d '
                      'duration_sec=%d duration_nsec=%d '
                      'idle_timeout=%d hard_timeout=%d '
                      'packet_count=%d byte_count=%d match.fields=%s',
                      msg.cookie, msg.priority, reason, msg.table_id,
                      msg.duration_sec, msg.duration_nsec,
                      msg.idle_timeout, msg.hard_timeout,
                      msg.packet_count, msg.byte_count, msg.match)
```

JSON Example:

```
{
  "OFPPFlowRemoved": {
    "byte_count": 86,
    "cookie": 0,
```



```

    "duration_nsec": 48825000,
    "duration_sec": 3,
    "hard_timeout": 0,
    "idle_timeout": 3,
    "match": {
        "OFPMatch": {
            "length": 14,
            "oxm_fields": [
                {
                    "OXMTlv": {
                        "field": "eth_dst",
                        "mask": null,
                        "value": "f2:0b:a4:7d:f8:ea"
                    }
                }
            ],
            "type": 1
        }
    },
    "packet_count": 1,
    "priority": 65535,
    "reason": 0,
    "table_id": 0
}

```

Port Status Message

class ryu.ofproto.ofproto_v1_4_parser.**OFPPortStatus** (*datapath*, *reason=None*, *desc=None*)

Port status message

The switch notifies controller of change of ports.

Attribute	Description
reason	One of the following values. OFPPR_ADD OFPPR_DELETE OFPPR_MODIFY
desc	instance of OFPPort

Example:

```

@set_ev_cls(ofp_event.EventOFPPortStatus, MAIN_DISPATCHER)
def port_status_handler(self, ev):
    msg = ev.msg
    dp = msg.datapath
    ofp = dp.ofproto

    if msg.reason == ofp.OFPPR_ADD:
        reason = 'ADD'
    elif msg.reason == ofp.OFPPR_DELETE:
        reason = 'DELETE'
    elif msg.reason == ofp.OFPPR_MODIFY:
        reason = 'MODIFY'

```

```

else:
    reason = 'unknown'

self.logger.debug('OFPPortStatus received: reason=%s desc=%s',
                  reason, msg.desc)

```

JSON Example:

```

{
  "OFPPortStatus": {
    "desc": {
      "OFPPort": {
        "config": 0,
        "hw_addr": "f2:0b:a4:d0:3f:70",
        "length": 168,
        "name": "\u79c1\u306e\u30dd\u30fc\u30c8",
        "port_no": 7,
        "properties": [
          {
            "OFPPortDescPropEthernet": {
              "advertised": 10240,
              "curr": 10248,
              "curr_speed": 5000,
              "length": 32,
              "max_speed": 5000,
              "peer": 10248,
              "supported": 10248,
              "type": 0
            }
          },
          {
            "OFPPortDescPropOptical": {
              "length": 40,
              "rx_grid_freq_lmda": 1500,
              "rx_max_freq_lmda": 2000,
              "rx_min_freq_lmda": 1000,
              "supported": 1,
              "tx_grid_freq_lmda": 1500,
              "tx_max_freq_lmda": 2000,
              "tx_min_freq_lmda": 1000,
              "tx_pwr_max": 2000,
              "tx_pwr_min": 1000,
              "type": 1
            }
          },
          {
            "OFPPortDescPropExperimenter": {
              "data": [],
              "exp_type": 0,
              "experimenter": 101,
              "length": 12,
              "type": 65535
            }
          },
          {
            "OFPPortDescPropExperimenter": {
              "data": [
                1
              ]
            }
          }
        ]
      }
    }
  }
}

```

```

        ],
        "exp_type": 1,
        "experimenter": 101,
        "length": 16,
        "type": 65535
    }
},
{
    "OFPPortDescPropExperimenter": {
        "data": [
            1,
            2
        ],
        "exp_type": 2,
        "experimenter": 101,
        "length": 20,
        "type": 65535
    }
},
],
"state": 4
}
},
"reason": 0
}
}

```

Controller Role Status Message

class ryu.ofproto.ofproto_v1_4_parser.**OFPCRoleStatus** (*datapath, role=None, reason=None, generation_id=None, properties=None*)

Role status message

The switch notifies controller of change of role.

Attribute	Description
role	One of the following values. OFPCR_ROLE_NOCHANGE OFPCR_ROLE_EQUAL OFPCR_ROLE_MASTER
reason	One of the following values. OFPCRR_MASTER_REQUEST OFPCRR_CONFIG OFPCRR_EXPERIMENTER
generation_id	Master Election Generation ID
properties	List of OFPCRoleProp subclass instance

Example:

```

@set_ev_cls(ofp_event.EventOFPCRoleStatus, MAIN_DISPATCHER)
def role_status_handler(self, ev):

```

```

msg = ev.msg
dp = msg.datapath
ofp = dp.ofproto

if msg.role == ofp.OFPCR_ROLE_NOCHANGE:
    role = 'ROLE NOCHANGE'
elif msg.role == ofp.OFPCR_ROLE_EQUAL:
    role = 'ROLE EQUAL'
elif msg.role == ofp.OFPCR_ROLE_MASTER:
    role = 'ROLE MASTER'
else:
    role = 'unknown'

if msg.reason == ofp.OFPCRR_MASTER_REQUEST:
    reason = 'MASTER REQUEST'
elif msg.reason == ofp.OFPCRR_CONFIG:
    reason = 'CONFIG'
elif msg.reason == ofp.OFPCRR_EXPERIMENTER:
    reason = 'EXPERIMENTER'
else:
    reason = 'unknown'

self.logger.debug('OFPPRoleStatus received: role=%s reason=%s '
                  'generation_id=%d properties=%s', role, reason,
                  msg.generation_id, repr(msg.properties))

```

JSON Example:

```

{
  "OFPPRoleStatus": {
    "generation_id": 7,
    "properties": [
      {
        "OFPPRolePropExperimenter": {
          "data": [],
          "exp_type": 0,
          "experimenter": 101,
          "length": 12,
          "type": 65535
        }
      },
      {
        "OFPPRolePropExperimenter": {
          "data": [
            1
          ],
          "exp_type": 1,
          "experimenter": 101,
          "length": 16,
          "type": 65535
        }
      },
      {
        "OFPPRolePropExperimenter": {
          "data": [
            1,
            2
          ],
          "exp_type": 2,

```

```

        "experimenter": 101,
        "length": 20,
        "type": 65535
    }
    ],
    "reason": 0,
    "role": 2
}
}

```

Table Status Message

class ryu.ofproto.ofproto_v1_4_parser.**OFPTTableStatus** (*datapath*, *reason=None*, *table=None*)

Table status message

The switch notifies controller of change of table status.

Attribute	Description
reason	One of the following values. OFPTR_VACANCY_DOWN OFPTR_VACANCY_UP
table	OFPTTableDesc instance

Example:

```

@set_ev_cls(ofp_event.EventOFPTTableStatus, MAIN_DISPATCHER)
def table(self, ev):
    msg = ev.msg
    dp = msg.datapath
    ofp = dp.ofproto

    if msg.reason == ofp.OFPTR_VACANCY_DOWN:
        reason = 'VACANCY_DOWN'
    elif msg.reason == ofp.OFPTR_VACANCY_UP:
        reason = 'VACANCY_UP'
    else:
        reason = 'unknown'

    self.logger.debug('OFPTTableStatus received: reason=%s '
                      'table_id=%d config=0x%08x properties=%s',
                      reason, msg.table.table_id, msg.table.config,
                      repr(msg.table.properties))

```

JSON Example:

```

{
  "OFPTTableStatus": {
    "reason": 3,
    "table": {
      "OFPTTableDesc": {
        "config": 0,
        "length": 80,
        "properties": [
          {

```

```
        "OFPTTableModPropEviction": {
            "flags": 0,
            "length": 8,
            "type": 2
        }
    },
    {
        "OFPTTableModPropVacancy": {
            "length": 8,
            "type": 3,
            "vacancy": 0,
            "vacancy_down": 0,
            "vacancy_up": 0
        }
    },
    {
        "OFPTTableModPropExperimenter": {
            "data": [],
            "exp_type": 0,
            "experimenter": 101,
            "length": 12,
            "type": 65535
        }
    },
    {
        "OFPTTableModPropExperimenter": {
            "data": [
                1
            ],
            "exp_type": 1,
            "experimenter": 101,
            "length": 16,
            "type": 65535
        }
    },
    {
        "OFPTTableModPropExperimenter": {
            "data": [
                1,
                2
            ],
            "exp_type": 2,
            "experimenter": 101,
            "length": 20,
            "type": 65535
        }
    }
],
"table_id": 8
}
}
}
```

Request Forward Message

class ryu.ofproto.ofproto_v1_4_parser.**OFPPRequestForward** (*datapath, request=None*)
Forwarded request message

The switch forwards request messages from one controller to other controllers.

Attribute	Description
request	OFPPGroupMod or OFPPMeterMod instance

Example:

```
@set_ev_cls(ofp_event.EventOFPPRequestForward, MAIN_DISPATCHER)
def request_forward_handler(self, ev):
    msg = ev.msg
    dp = msg.datapath
    ofp = dp.ofproto

    if msg.request.msg_type == ofp.OFPT_GROUP_MOD:
        self.logger.debug(
            'OFPPRequestForward received: request=OFPPGroupMod('
            'command=%d, type=%d, group_id=%d, buckets=%s)',
            msg.request.command, msg.request.type,
            msg.request.group_id, msg.request.buckets)
    elif msg.request.msg_type == ofp.OFPT_METER_MOD:
        self.logger.debug(
            'OFPPRequestForward received: request=OFPPMeterMod('
            'command=%d, flags=%d, meter_id=%d, bands=%s)',
            msg.request.command, msg.request.flags,
            msg.request.meter_id, msg.request.bands)
    else:
        self.logger.debug(
            'OFPPRequestForward received: request=Unknown')
```

JSON Example:

```
{
  "OFPPRequestForward": {
    "request": {
      "OFPPGroupMod": {
        "buckets": [
          {
            "OFPPBucket": {
              "actions": [
                {
                  "OFPPActionOutput": {
                    "len": 16,
                    "max_len": 65535,
                    "port": 2,
                    "type": 0
                  }
                }
              ]
            }
          ],
          "len": 32,
          "watch_group": 1,
          "watch_port": 1,
          "weight": 1
        ]
      }
    }
  },
}
```

```

        "command": 0,
        "group_id": 1,
        "type": 0
    }
}
}
}

```

Symmetric Messages

Hello

class ryu.ofproto.ofproto_v1_4_parser.**OFPHello** (*datapath*, *elements=None*)
 Hello message

When connection is started, the hello message is exchanged between a switch and a controller.

This message is handled by the Ryu framework, so the Ryu application do not need to process this typically.

Attribute	Description
elements	list of OFPHelloElemVersionBitmap instance

JSON Example:

```

{
  "OFPHello": {
    "elements": [
      {
        "OFPHelloElemVersionBitmap": {
          "length": 8,
          "type": 1,
          "versions": [
            1,
            2,
            3,
            9,
            10,
            30
          ]
        }
      }
    ]
  }
}

```

class ryu.ofproto.ofproto_v1_4_parser.**OFPHelloElemVersionBitmap** (*versions*,
type_=None,
length=None)

Version bitmap Hello Element

Attribute	Description
versions	list of versions of OpenFlow protocol a device supports

Echo Request

class ryu.ofproto.ofproto_v1_4_parser.**OFPEchoRequest** (*datapath*, *data=None*)
 Echo request message

This message is handled by the Ryu framework, so the Ryu application do not need to process this typically.

Attribute	Description
data	An arbitrary length data

Example:

```
def send_echo_request(self, datapath, data):
    ofp = datapath.ofproto
    ofp_parser = datapath.ofproto_parser

    req = ofp_parser.OFPEchoRequest(datapath, data)
    datapath.send_msg(req)

@set_ev_cls(ofp_event.EventOFPEchoRequest,
            [HANDSHAKE_DISPATCHER, CONFIG_DISPATCHER, MAIN_DISPATCHER])
def echo_request_handler(self, ev):
    self.logger.debug('OFPEchoRequest received: data=%s',
                      utils.hex_array(ev.msg.data))
```

JSON Example:

```
{
  "OFPEchoRequest": {
    "data": "aG9nZQ=="
  }
}
```

Echo Reply

class ryu.ofproto.ofproto_v1_4_parser.**OFPEchoReply** (*datapath, data=None*)
Echo reply message

This message is handled by the Ryu framework, so the Ryu application do not need to process this typically.

Attribute	Description
data	An arbitrary length data

Example:

```
def send_echo_reply(self, datapath, data):
    ofp_parser = datapath.ofproto_parser

    reply = ofp_parser.OFPEchoReply(datapath, data)
    datapath.send_msg(reply)

@set_ev_cls(ofp_event.EventOFPEchoReply,
            [HANDSHAKE_DISPATCHER, CONFIG_DISPATCHER, MAIN_DISPATCHER])
def echo_reply_handler(self, ev):
    self.logger.debug('OFPEchoReply received: data=%s',
                      utils.hex_array(ev.msg.data))
```

JSON Example:

```
{
  "OFPEchoReply": {
    "data": "aG9nZQ=="
  }
}
```

Error Message

`class ryu.ofproto.ofproto_v1_4_parser.OFPErrormsg` (*datapath*, *type_=None*, *code=None*, *data=None*)

Error message

The switch notifies controller of problems by this message.

Attribute	Description
type	High level type of error
code	Details depending on the type
data	Variable length data depending on the type and code

type attribute corresponds to `type_` parameter of `__init__`.

Types and codes are defined in `ryu.ofproto.ofproto`.

Type	Code
OFPET_HELLO_FAILED	OFPHFC_*
OFPET_BAD_REQUEST	OFPBRC_*
OFPET_BAD_ACTION	OFPBAC_*
OFPET_BAD_INSTRUCTION	OFPBIC_*
OFPET_BAD_MATCH	OFPBMC_*
OFPET_FLOW_MOD_FAILED	OFPFMFC_*
OFPET_GROUP_MOD_FAILED	OFPGMFC_*
OFPET_PORT_MOD_FAILED	OFPPMFC_*
OFPET_TABLE_MOD_FAILED	OFPTMFC_*
OFPET_QUEUE_OP_FAILED	OFPQOFC_*
OFPET_SWITCH_CONFIG_FAILED	OFPSCFC_*
OFPET_ROLE_REQUEST_FAILED	OFPRRFC_*
OFPET_METER_MOD_FAILED	OFPPMFC_*
OFPET_TABLE_FEATURES_FAILED	OFPTFFC_*
OFPET_EXPERIMENTER	N/A

Example:

```
@set_ev_cls(ofp_event.EventOFPErrormsg,
            [HANDSHAKE_DISPATCHER, CONFIG_DISPATCHER, MAIN_DISPATCHER])
def error_msg_handler(self, ev):
    msg = ev.msg

    self.logger.debug('OFPErrormsg received: type=0x%02x code=0x%02x '
                      'message=%s',
                      msg.type, msg.code, utils.hex_array(msg.data))
```

JSON Example:

```
{
  "OFPErrormsg": {
    "code": 11,
    "data": "ZnVnYWZ1Z2E=",
    "type": 2
  }
}
```

Experimenter

class ryu.ofproto.ofproto_v1_4_parser.**OFPEExperimenter** (*datapath*, *experimenter=None*, *exp_type=None*, *data=None*)

Experimenter extension message

Attribute	Description
experimenter	Experimenter ID
exp_type	Experimenter defined
data	Experimenter defined arbitrary additional data

JSON Example:

```
{
  "OFPEExperimenter": {
    "data": "bmF6bw==",
    "exp_type": 123456789,
    "experimenter": 98765432
  }
}
```

Port Structures

class ryu.ofproto.ofproto_v1_4_parser.**OFPPort** (*port_no=None*, *length=None*, *hw_addr=None*, *name=None*, *config=None*, *state=None*, *properties=None*)

Description of a port

Attribute	Description
port_no	Port number and it uniquely identifies a port within a switch.
length	Length of ofp_port (excluding padding).
hw_addr	MAC address for the port.
name	Null-terminated string containing a human-readable name for the interface.
config	Bitmap of port configuration flags. OFPPC_PORT_DOWN OFPPC_NO_RECV OFPPC_NO_FWD OFPPC_NO_PACKET_IN
state	Bitmap of port state flags. OFPPS_LINK_DOWN OFPPS_BLOCKED OFPPS_LIVE
properties	List of OFPPortDescProp subclass instance

Flow Match Structure

```
class ryu.ofproto.ofproto_v1_4_parser.OFPMatch (type_=None, length=None, _or-
                                             dered_fields=None, **kwargs)
```

Flow Match Structure

This class is implementation of the flow match structure having compose/query API.

You can define the flow match by the keyword arguments. The following arguments are available.

Argument	Value	Description
in_port	Integer 32bit	Switch input port
in_phy_port	Integer 32bit	Switch physical input port
metadata	Integer 64bit	Metadata passed between tables
eth_dst	MAC address	Ethernet destination address
eth_src	MAC address	Ethernet source address
eth_type	Integer 16bit	Ethernet frame type
vlan_vid	Integer 16bit	VLAN id
vlan_pcp	Integer 8bit	VLAN priority
ip_dscp	Integer 8bit	IP DSCP (6 bits in ToS field)
ip_ecn	Integer 8bit	IP ECN (2 bits in ToS field)
ip_proto	Integer 8bit	IP protocol
ipv4_src	IPv4 address	IPv4 source address
ipv4_dst	IPv4 address	IPv4 destination address
tcp_src	Integer 16bit	TCP source port
tcp_dst	Integer 16bit	TCP destination port
udp_src	Integer 16bit	UDP source port
udp_dst	Integer 16bit	UDP destination port
sctp_src	Integer 16bit	SCTP source port
sctp_dst	Integer 16bit	SCTP destination port
icmpv4_type	Integer 8bit	ICMP type
icmpv4_code	Integer 8bit	ICMP code
arp_op	Integer 16bit	ARP opcode
arp_spa	IPv4 address	ARP source IPv4 address
arp_tpa	IPv4 address	ARP target IPv4 address
arp_sha	MAC address	ARP source hardware address
arp_tha	MAC address	ARP target hardware address
ipv6_src	IPv6 address	IPv6 source address
ipv6_dst	IPv6 address	IPv6 destination address
ipv6_flabel	Integer 32bit	IPv6 Flow Label
icmpv6_type	Integer 8bit	ICMPv6 type
icmpv6_code	Integer 8bit	ICMPv6 code
ipv6_nd_target	IPv6 address	Target address for ND
ipv6_nd_sll	MAC address	Source link-layer for ND
ipv6_nd_tll	MAC address	Target link-layer for ND
mpls_label	Integer 32bit	MPLS label
mpls_tc	Integer 8bit	MPLS TC
mpls_bos	Integer 8bit	MPLS BoS bit
pbb_isid	Integer 24bit	PBB I-SID
tunnel_id	Integer 64bit	Logical Port Metadata
ipv6_exthdr	Integer 16bit	IPv6 Extension Header pseudo-field
pbb_uca	Integer 8bit	PBB UCA header field
tcp_flags	Integer 16bit	TCP flags (EXT-109 ONF Extension)

Continued on next page

Table 2.3 – continued from previous page

Argument	Value	Description
actset_output	Integer 32bit	Output port from action set metadata (EXT-233 ONF Extension)

Example:

```
>>> # compose
>>> match = parser.OFPMatch(
...     in_port=1,
...     eth_type=0x86dd,
...     ipv6_src=('2001:db8:bd05:1d2:288a:1fc0:1:10ee',
...               'ffff:ffff:ffff:ffff::'),
...     ipv6_dst='2001:db8:bd05:1d2:288a:1fc0:1:10ee')
>>> # query
>>> if 'ipv6_src' in match:
...     print match['ipv6_src']
...
('2001:db8:bd05:1d2:288a:1fc0:1:10ee', 'ffff:ffff:ffff:ffff::')
```

Note: For the list of the supported Nicira experimenter matches, please refer to [ryu.ofproto.nx_match](#).

Note: For VLAN id match field, special values are defined in OpenFlow Spec.

1. Packets with and without a VLAN tag

•Example:

```
match = parser.OFPMatch()
```

•Packet Matching

non-VLAN-tagged	MATCH
VLAN-tagged(vlan_id=3)	MATCH
VLAN-tagged(vlan_id=5)	MATCH

2. Only packets without a VLAN tag

•Example:

```
match = parser.OFPMatch(vlan_vid=0x0000)
```

•Packet Matching

non-VLAN-tagged	MATCH
VLAN-tagged(vlan_id=3)	x
VLAN-tagged(vlan_id=5)	x

3. Only packets with a VLAN tag regardless of its value

•Example:

```
match = parser.OFPMatch(vlan_vid=(0x1000, 0x1000))
```

•Packet Matching

non-VLAN-tagged	x
VLAN-tagged(vlan_id=3)	MATCH
VLAN-tagged(vlan_id=5)	MATCH

4. Only packets with VLAN tag and VID equal

•Example:

```
match = parser.OFPMatch(vlan_vid=(0x1000 | 3))
```

•Packet Matching

non-VLAN-tagged	x
VLAN-tagged(vlan_id=3)	MATCH
VLAN-tagged(vlan_id=5)	x

Flow Instruction Structures

class ryu.ofproto.ofproto_v1_4_parser.**OFPIInstructionGotoTable** (*table_id*,
type_=None,
len_=None)

Goto table instruction

This instruction indicates the next table in the processing pipeline.

Attribute	Description
table_id	Next table

class ryu.ofproto.ofproto_v1_4_parser.**OFPIInstructionWriteMetadata** (*metadata*,
meta-
data_mask,
type_=None,
len_=None)

Write metadata instruction

This instruction writes the masked metadata value into the metadata field.

Attribute	Description
metadata	Metadata value to write
metadata_mask	Metadata write bitmask

class ryu.ofproto.ofproto_v1_4_parser.**OFPIInstructionActions** (*type_*, *actions=None*,
len_=None)

Actions instruction

This instruction writes/applies/clears the actions.

Attribute	Description
type	One of following values. OFPIT_WRITE_ACTIONS OFPIT_APPLY_ACTIONS OFPIT_CLEAR_ACTIONS
actions	list of OpenFlow action class

type attribute corresponds to type_ parameter of __init__.

class ryu.ofproto.ofproto_v1_4_parser.**OFFInstructionMeter** (*meter_id=1, type_=None, len_=None*)

Meter instruction

This instruction applies the meter.

Attribute	Description
meter_id	Meter instance

Action Structures

class ryu.ofproto.ofproto_v1_4_parser.**OFFActionOutput** (*port, max_len=65509, type_=None, len_=None*)

Output action

This action indicates output a packet to the switch port.

Attribute	Description
port	Output port
max_len	Max length to send to controller

class ryu.ofproto.ofproto_v1_4_parser.**OFFActionCopyTtlOut** (*type_=None, len_=None*)
Copy TTL Out action

This action copies the TTL from the next-to-outermost header with TTL to the outermost header with TTL.

class ryu.ofproto.ofproto_v1_4_parser.**OFFActionCopyTtlIn** (*type_=None, len_=None*)
Copy TTL In action

This action copies the TTL from the outermost header with TTL to the next-to-outermost header with TTL.

class ryu.ofproto.ofproto_v1_4_parser.**OFFActionSetMplsTtl** (*mpls_ttl, type_=None, len_=None*)

Set MPLS TTL action

This action sets the MPLS TTL.

Attribute	Description
mpls_ttl	MPLS TTL

class ryu.ofproto.ofproto_v1_4_parser.**OFFActionDecMplsTtl** (*type_=None, len_=None*)
Decrement MPLS TTL action

This action decrements the MPLS TTL.

class ryu.ofproto.ofproto_v1_4_parser.**OFFActionPushVlan** (*ethertype=33024, type_=None, len_=None*)

Push VLAN action

This action pushes a new VLAN tag to the packet.

Attribute	Description
ethertype	Ether type. The default is 802.1Q. (0x8100)

class ryu.ofproto.ofproto_v1_4_parser.**OFFActionPopVlan** (*type_=None, len_=None*)
Pop VLAN action

This action pops the outermost VLAN tag from the packet.

class ryu.ofproto.ofproto_v1_4_parser.**OFFActionPushMpls** (*ethertype=34887, type_=None, len_=None*)

Push MPLS action

This action pushes a new MPLS header to the packet.

Attribute	Description
ethertype	Ether type

class ryu.ofproto.ofproto_v1_4_parser.**OFFActionPopMpls** (*ethertype=2048, type_=None, len_=None*)

Pop MPLS action

This action pops the MPLS header from the packet.

class ryu.ofproto.ofproto_v1_4_parser.**OFFActionSetQueue** (*queue_id, type_=None, len_=None*)

Set queue action

This action sets the queue id that will be used to map a flow to an already-configured queue on a port.

Attribute	Description
queue_id	Queue ID for the packets

class ryu.ofproto.ofproto_v1_4_parser.**OFFActionGroup** (*group_id=0, type_=None, len_=None*)

Group action

This action indicates the group used to process the packet.

Attribute	Description
group_id	Group identifier

class ryu.ofproto.ofproto_v1_4_parser.**OFFActionSetNwTtl** (*nw_ttl, type_=None, len_=None*)

Set IP TTL action

This action sets the IP TTL.

Attribute	Description
nw_ttl	IP TTL

class ryu.ofproto.ofproto_v1_4_parser.**OFFActionDecNwTtl** (*type_=None, len_=None*)

Decrement IP TTL action

This action decrements the IP TTL.

class ryu.ofproto.ofproto_v1_4_parser.**OFFActionSetField** (*field=None, **kwargs*)

Set field action

This action modifies a header field in the packet.

The set of keywords available for this is same as OFFMatch.

Example:

```
set_field = OFFActionSetField(eth_src="00:00:00:00:00:00")
```

class ryu.ofproto.ofproto_v1_4_parser.**OFFActionPushPbb** (*ethertype, type_=None, len_=None*)

Push PBB action

This action pushes a new PBB header to the packet.

Attribute	Description
ethertype	Ether type

class ryu.ofproto.ofproto_v1_4_parser.**OFFActionPopPbb** (*type_=None, len_=None*)

Pop PBB action

This action pops the outermost PBB service instance header from the packet.

class `ryu.ofproto.ofproto_v1_4_parser.OFPActionExperimenter` (*experimenter*)
 Experimenter action

This action is an extensible action for the experimenter.

Attribute	Description
<code>experimenter</code>	Experimenter ID

Note: For the list of the supported Nicira experimenter actions, please refer to *ryu.ofproto.nx_actions*.

2.5.6 OpenFlow v1.5 Messages and Structures

Controller-to-Switch Messages

Handshake

class `ryu.ofproto.ofproto_v1_5_parser.OFPFeaturesRequest` (*datapath*)
 Features request message

The controller sends a feature request to the switch upon session establishment.

This message is handled by the Ryu framework, so the Ryu application do not need to process this typically.

Example:

```
def send_features_request(self, datapath):
    ofp_parser = datapath.ofproto_parser

    req = ofp_parser.OFPFeaturesRequest(datapath)
    datapath.send_msg(req)
```

JSON Example:

```
{
  "OFPFeaturesRequest": {}
}
```

class `ryu.ofproto.ofproto_v1_5_parser.OFPSwitchFeatures` (*datapath*, *datapath_id=None*,
n_buffers=None,
n_tables=None, *auxiliary_id=None*, *capabilities=None*)

Features reply message

The switch responds with a features reply message to a features request.

This message is handled by the Ryu framework, so the Ryu application do not need to process this typically.

Example:

```
@set_ev_cls(ofp_event.EventOFPSwitchFeatures, CONFIG_DISPATCHER)
def switch_features_handler(self, ev):
    msg = ev.msg

    self.logger.debug('OFPSwitchFeatures received: '
                      'datapath_id=0x%016x n_buffers=%d '
                      'n_tables=%d auxiliary_id=%d '
                      'capabilities=0x%08x',
```

```
msg.datapath_id, msg.n_buffers, msg.n_tables,
msg.auxiliary_id, msg.capabilities)
```

JSON Example:

```
{
  "OFPSwitchFeatures": {
    "auxiliary_id": 0,
    "capabilities": 79,
    "datapath_id": 1,
    "n_buffers": 255,
    "n_tables": 255
  }
}
```

Switch Configuration

class ryu.ofproto.ofproto_v1_5_parser.**OFPSetConfig** (*datapath, flags=0, miss_send_len=0*)
Set config request message

The controller sends a set config request message to set configuration parameters.

Attribute	Description
flags	Bitmap of the following flags. OFPC_FRAG_NORMAL OFPC_FRAG_DROP OFPC_FRAG_REASM
miss_send_len	Max bytes of new flow that datapath should send to the controller

Example:

```
def send_set_config(self, datapath):
    ofp = datapath.ofproto
    ofp_parser = datapath.ofproto_parser

    req = ofp_parser.OFPSetConfig(datapath, ofp.OFPC_FRAG_NORMAL, 256)
    datapath.send_msg(req)
```

JSON Example:

```
{
  "OFPSetConfig": {
    "flags": 0,
    "miss_send_len": 128
  }
}
```

class ryu.ofproto.ofproto_v1_5_parser.**OFPGetConfigRequest** (*datapath*)
Get config request message

The controller sends a get config request to query configuration parameters in the switch.

Example:

```
def send_get_config_request(self, datapath):
    ofp_parser = datapath.ofproto_parser

    req = ofp_parser.OFPGetConfigRequest(datapath)
    datapath.send_msg(req)
```

JSON Example:

```
{
  "OFPGetConfigRequest": {}
}
```

```
class ryu.ofproto.ofproto_v1_5_parser.OFPGetConfigReply(datapath,
                                                       flags=None,
                                                       miss_send_len=None)
```

Get config reply message

The switch responds to a configuration request with a get config reply message.

Attribute	Description
flags	Bitmap of the following flags. OFPC_FRAG_NORMAL OFPC_FRAG_DROP OFPC_FRAG_REASM
miss_send_len	Max bytes of new flow that datapath should send to the controller

Example:

```
@set_ev_cls(ofp_event.EventOFPGetConfigReply, MAIN_DISPATCHER)
def get_config_reply_handler(self, ev):
    msg = ev.msg
    dp = msg.datapath
    ofp = dp.ofproto
    flags = []

    if msg.flags & ofp.OFPC_FRAG_NORMAL:
        flags.append('NORMAL')
    if msg.flags & ofp.OFPC_FRAG_DROP:
        flags.append('DROP')
    if msg.flags & ofp.OFPC_FRAG_REASM:
        flags.append('REASM')
    self.logger.debug('OFPGetConfigReply received: '
                    'flags=%s miss_send_len=%d',
                    ','.join(flags), msg.miss_send_len)
```

JSON Example:

```
{
  "OFPGetConfigReply": {
    "flags": 0,
    "miss_send_len": 128
  }
}
```

Modify State Messages

class ryu.ofproto.ofproto_v1_5_parser.**OFPTTableMod** (*datapath, table_id, config, properties*)

Flow table configuration message

The controller sends this message to configure table state.

Attribute	Description
table_id	ID of the table (OFPTT_ALL indicates all tables)
config	Bitmap of configuration flags. OFPTC_EVICTION OFPTC_VACANCY_EVENTS
properties	List of OFPTTableModProp subclass instance

Example:

```
def send_table_mod(self, datapath):
    ofp = datapath.ofproto
    ofp_parser = datapath.ofproto_parser

    req = ofp_parser.OFPTTableMod(datapath, 1, 3)
    flags = ofp.OFPTC_VACANCY_EVENTS
    properties = [ofp_parser.OFPTTableModPropEviction(flags)]
    req = ofp_parser.OFPTTableMod(datapath, 1, 3, properties)
    datapath.send_msg(req)
```

JSON Example:

```
{
  "OFPTTableMod": {
    "config": 4,
    "properties": [
      {
        "OFPTTableModPropEviction": {
          "flags": 2,
          "length": 8,
          "type": 2
        }
      }
    ],
    "table_id": 255
  }
}
```

class ryu.ofproto.ofproto_v1_5_parser.**OFPFLOWMod** (*datapath, cookie=0, cookie_mask=0, table_id=0, command=0, idle_timeout=0, hard_timeout=0, priority=32768, buffer_id=4294967295, out_port=0, out_group=0, flags=0, importance=0, match=None, instructions=None*)

Modify Flow entry message

The controller sends this message to modify the flow table.

Attribute	Description
cookie	Opaque controller-issued identifier
cookie_mask	Mask used to restrict the cookie bits that must match when the command is OFPFC_MODIFY* or OFPFC_DELETE*
table_id	ID of the table to put the flow in
command	One of the following values. OFPFC_ADD OFPFC_MODIFY OFPFC_MODIFY_STRICT OFPFC_DELETE OFPFC_DELETE_STRICT
idle_timeout	Idle time before discarding (seconds)
hard_timeout	Max time before discarding (seconds)
priority	Priority level of flow entry
buffer_id	Buffered packet to apply to (or OFP_NO_BUFFER)
out_port	For OFPFC_DELETE* commands, require matching entries to include this as an output port
out_group	For OFPFC_DELETE* commands, require matching entries to include this as an output group
flags	Bitmap of the following flags. OFPFF_SEND_FLOW_REM OFPFF_CHECK_OVERLAP OFPFF_RESET_COUNTS OFPFF_NO_PKT_COUNTS OFPFF_NO_BYT_COUNTS
importance	Eviction precedence
match	Instance of OFPMatch
instructions	list of OFPInstruction* instance

Example:

```
def send_flow_mod(self, datapath):
    ofp = datapath.ofproto
    ofp_parser = datapath.ofproto_parser

    cookie = cookie_mask = 0
    table_id = 0
    idle_timeout = hard_timeout = 0
    priority = 32768
    buffer_id = ofp.OFP_NO_BUFFER
    importance = 0
    match = ofp_parser.OFPMatch(in_port=1, eth_dst='ff:ff:ff:ff:ff:ff')
    actions = [ofp_parser.OFPActionOutput(ofp.OFPP_NORMAL, 0)]
    inst = [ofp_parser.OFPInstructionActions(ofp.OFPIT_APPLY_ACTIONS,
                                             actions)]

    req = ofp_parser.OFPFlowMod(datapath, cookie, cookie_mask,
                                table_id, ofp.OFPFC_ADD,
                                idle_timeout, hard_timeout,
                                priority, buffer_id,
                                ofp.OFPP_ANY, ofp.OFPG_ANY,
```

```

                                ofp.OFPFF_SEND_FLOW_REM,
                                importance,
                                match, inst)
datapath.send_msg(req)

```

JSON Example:

```

{
  "OFPFlowMod": {
    "buffer_id": 0,
    "command": 0,
    "cookie": 1311768467463790320,
    "cookie_mask": 18446744073709551615,
    "flags": 0,
    "hard_timeout": 0,
    "idle_timeout": 0,
    "importance": 39032,
    "instructions": [
      {
        "OFPInstructionActions": {
          "actions": [
            {
              "OFPActionPopVlan": {
                "len": 8,
                "type": 18
              }
            },
            {
              "OFPActionSetField": {
                "field": {
                  "OXMTlv": {
                    "field": "ipv4_dst",
                    "mask": null,
                    "value": "192.168.2.9"
                  }
                }
              },
              "len": 16,
              "type": 25
            }
          ]
        },
        "NXActionLearn": {
          "cookie": 0,
          "experimenter": 8992,
          "fin_hard_timeout": 0,
          "fin_idle_timeout": 0,
          "flags": 0,
          "hard_timeout": 300,
          "idle_timeout": 0,
          "len": 96,
          "priority": 1,
          "specs": [
            {
              "NXFlowSpecMatch": {
                "dst": [
                  "vlan_vid",
                  0
                ]
              }
            }
          ]
        }
      ]
    }
  }
}

```

```

        "n_bits": 12,
        "src": [
            "vlan_vid",
            0
        ]
    },
    {
        "NXFlowSpecMatch": {
            "dst": [
                "eth_dst_nxm",
                0
            ],
            "n_bits": 48,
            "src": [
                "eth_src_nxm",
                0
            ]
        }
    },
    {
        "NXFlowSpecLoad": {
            "dst": [
                "vlan_vid",
                0
            ],
            "n_bits": 12,
            "src": 0
        }
    },
    {
        "NXFlowSpecLoad": {
            "dst": [
                "tunnel_id_nxm",
                0
            ],
            "n_bits": 64,
            "src": [
                "tunnel_id_nxm",
                0
            ]
        }
    },
    {
        "NXFlowSpecOutput": {
            "dst": "",
            "n_bits": 32,
            "src": [
                "in_port",
                0
            ]
        }
    }
],
"subtype": 16,
"table_id": 99,
"type": 65535
}

```

```
    }
    ],
    "len": 128,
    "type": 4
  }
},
{
  "OFFInstructionGotoTable": {
    "len": 8,
    "table_id": 100,
    "type": 1
  }
}
],
"match": {
  "OFFPMatch": {
    "length": 70,
    "oxm_fields": [
      {
        "OXMTlv": {
          "field": "in_port",
          "mask": null,
          "value": 43981
        }
      },
      {
        "OXMTlv": {
          "field": "eth_dst",
          "mask": null,
          "value": "aa:bb:cc:99:88:77"
        }
      },
      {
        "OXMTlv": {
          "field": "eth_type",
          "mask": null,
          "value": 2048
        }
      },
      {
        "OXMTlv": {
          "field": "vlan_vid",
          "mask": null,
          "value": 5095
        }
      },
      {
        "OXMTlv": {
          "field": "ipv4_dst",
          "mask": null,
          "value": "192.168.2.1"
        }
      },
      {
        "OXMTlv": {
          "field": "tunnel_id",
          "mask": null,
          "value": 50000
        }
      }
    ]
  }
}
```



```

    }
    },
    {
      "OXMTlv": {
        "field": "tun_ipv4_src",
        "mask": null,
        "value": "192.168.2.3"
      }
    },
    {
      "OXMTlv": {
        "field": "tun_ipv4_dst",
        "mask": null,
        "value": "192.168.2.4"
      }
    }
  ],
  "type": 1
}
},
"out_group": 0,
"out_port": 0,
"priority": 0,
"table_id": 2
}
}

```

```

{
  "OFPFFlowMod": {
    "buffer_id": 0,
    "command": 0,
    "cookie": 1311768467463790320,
    "cookie_mask": 18446744073709551615,
    "flags": 0,
    "hard_timeout": 0,
    "idle_timeout": 0,
    "importance": 39032,
    "instructions": [
      {
        "OFPIInstructionActions": {
          "actions": [
            {
              "NXActionConjunction": {
                "clause": 1,
                "experimenter": 8992,
                "id": 11259375,
                "len": 16,
                "n_clauses": 2,
                "subtype": 34,
                "type": 65535
              }
            }
          ]
        },
        "len": 24,
        "type": 4
      }
    ]
  }
}

```

```
"match": {
  "OFPMatch": {
    "length": 70,
    "oxm_fields": [
      {
        "OXMTlv": {
          "field": "in_port",
          "mask": null,
          "value": 43981
        }
      },
      {
        "OXMTlv": {
          "field": "eth_dst",
          "mask": null,
          "value": "aa:bb:cc:99:88:77"
        }
      },
      {
        "OXMTlv": {
          "field": "eth_type",
          "mask": null,
          "value": 2048
        }
      },
      {
        "OXMTlv": {
          "field": "vlan_vid",
          "mask": null,
          "value": 5095
        }
      },
      {
        "OXMTlv": {
          "field": "ipv4_dst",
          "mask": null,
          "value": "192.168.2.1"
        }
      },
      {
        "OXMTlv": {
          "field": "tunnel_id",
          "mask": null,
          "value": 50000
        }
      },
      {
        "OXMTlv": {
          "field": "tun_ipv4_src",
          "mask": null,
          "value": "192.168.2.3"
        }
      },
      {
        "OXMTlv": {
          "field": "tun_ipv4_dst",
          "mask": null,
          "value": "192.168.2.4"
        }
      }
    ]
  }
}
```

```

        }
    },
    "type": 1
}
},
"out_group": 0,
"out_port": 0,
"priority": 0,
"table_id": 4
}
}

```

```

{
  "OFFFlowMod": {
    "buffer_id": 0,
    "command": 0,
    "cookie": 1311768467463790320,
    "cookie_mask": 18446744073709551615,
    "flags": 0,
    "hard_timeout": 0,
    "idle_timeout": 0,
    "importance": 39032,
    "instructions": [
      {
        "OFFInstructionActions": {
          "actions": [
            {
              "OFFActionPopVlan": {
                "len": 8,
                "type": 18
              }
            },
            {
              "OFFActionSetField": {
                "field": {
                  "OXMTlv": {
                    "field": "ipv4_dst",
                    "mask": null,
                    "value": "192.168.2.9"
                  }
                },
                "len": 16,
                "type": 25
              }
            }
          ]
        },
        "len": 32,
        "type": 4
      }
    ],
    {
      "OFFInstructionGotoTable": {
        "len": 8,
        "table_id": 100,
        "type": 1
      }
    }
  }
}

```

```

    ],
    "match": {
        "OFPMatch": {
            "length": 12,
            "oxm_fields": [
                {
                    "OXMTlv": {
                        "field": "conj_id",
                        "mask": null,
                        "value": 11259375
                    }
                }
            ],
            "type": 1
        }
    },
    "out_group": 0,
    "out_port": 0,
    "priority": 0,
    "table_id": 3
}
}

```

class ryu.ofproto.ofproto_v1_5_parser.**OFPGGroupMod** (*datapath*, *command=0*, *type_=0*, *group_id=0*, *command_bucket_id=0*, *buckets=None*, *properties=None*, *bucket_array_len=None*)

Modify group entry message

The controller sends this message to modify the group table.

Attribute	Description
command	One of the following values. OFPGC_ADD OFPGC_MODIFY OFPGC_DELETE OFPGC_INSERT_BUCKET OFPGC_REMOVE_BUCKET
type	One of the following values. OFPGT_ALL OFPGT_SELECT OFPGT_INDIRECT OFPGT_FF
group_id	Group identifier.
command_bucket_id	Bucket Id used as part of OFPGC_INSERT_BUCKET and OFPGC_REMOVE_BUCKET commands execution.
buckets	List of OFPBucket instance
properties	List of OFPGroupProp instance

type attribute corresponds to type_ parameter of __init__.

Example:

```
def send_group_mod(self, datapath):
    ofp = datapath.ofproto
    ofp_parser = datapath.ofproto_parser

    port = 1
    max_len = 2000
    actions = [ofp_parser.OFPActionOutput(port, max_len)]

    weight = 100
    watch_port = 0
    watch_group = 0
    buckets = [ofp_parser.OFPBucket(weight, watch_port, watch_group,
                                    actions)]

    group_id = 1
    command_bucket_id=1
    req = ofp_parser.OFPGroupMod(datapath, ofp.OFPGC_ADD,
                                 ofp.OFPGT_SELECT, group_id,
                                 command_bucket_id, buckets)

    datapath.send_msg(req)
```

JSON Example:

```
{
  "OFPGroupMod": {
    "bucket_array_len": 56,
    "buckets": [
      {
        "OFPBucket": {
          "action_array_len": 24,
          "actions": [
            {
              "OFPActionPopVlan": {
                "len": 8,
                "type": 18
              }
            },
            {
              "OFPActionSetField": {
                "field": {
                  "OXMTlv": {
                    "field": "ipv4_dst",
                    "mask": null,
                    "value": "192.168.2.9"
                  }
                },
                "len": 16,
                "type": 25
              }
            }
          ],
          "bucket_id": 305419896,
          "len": 56,
          "properties": [
            {
              "OFPGroupBucketPropWeight": {
                "length": 8,
```

```

        "type": 0,
        "weight": 52428
    },
    {
        "OFPPortPropWatch": {
            "length": 8,
            "type": 1,
            "watch": 56797
        }
    },
    {
        "OFPPortPropWatch": {
            "length": 8,
            "type": 2,
            "watch": 4008636142
        }
    }
]
}
],
"command": 3,
"command_bucket_id": 3149642683,
"group_id": 2863311530,
"properties": [],
"type": 1
}
}

```

class ryu.ofproto.ofproto_v1_5_parser.**OFPPortMod** (*datapath*, *port_no=0*, *hw_addr='00:00:00:00:00:00'*, *config=0*, *mask=0*, *properties=None*)

Port modification message

The controller sends this message to modify the behavior of the port.

Attribute	Description
port_no	Port number to modify
hw_addr	The hardware address that must be the same as hw_addr of OFPPort of OFPSwitchFeatures
config	Bitmap of configuration flags. OFPPC_PORT_DOWN OFPPC_NO_RECV OFPPC_NO_FWD OFPPC_NO_PACKET_IN
mask	Bitmap of configuration flags above to be changed
properties	List of OFPPortModProp subclass instance

Example:

```

def send_port_mod(self, datapath):
    ofp = datapath.ofproto
    ofp_parser = datapath.ofproto_parser

    port_no = 3

```

```

hw_addr = 'fa:c8:e8:76:1d:7e'
config = 0
mask = (ofp.OFPPC_PORT_DOWN | ofp.OFPPC_NO_RECV |
        ofp.OFPPC_NO_FWD | ofp.OFPPC_NO_PACKET_IN)
advertise = (ofp.OFPPF_10MB_FD | ofp.OFPPF_100MB_FD |
             ofp.OFPPF_1GB_FD | ofp.OFPPF_COPPER |
             ofp.OFPPF_AUTONEG | ofp.OFPPF_PAUSE |
             ofp.OFPPF_PAUSE_ASYM)
properties = [ofp_parser.OFPPortModPropEthernet(advertise)]
req = ofp_parser.OFPPortMod(datapath, port_no, hw_addr, config,
                             mask, properties)

datapath.send_msg(req)

```

JSON Example:

```

{
  "OFPPortMod": {
    "config": 0,
    "hw_addr": "00:11:00:00:11:11",
    "mask": 0,
    "port_no": 1,
    "properties": [
      {
        "OFPPortModPropEthernet": {
          "advertise": 4096,
          "length": 8,
          "type": 0
        }
      },
      {
        "OFPPortModPropOptical": {
          "configure": 3,
          "fl_offset": 2000,
          "freq_lmda": 1500,
          "grid_span": 3000,
          "length": 24,
          "tx_pwr": 300,
          "type": 1
        }
      },
      {
        "OFPPortModPropExperimenter": {
          "data": [],
          "exp_type": 0,
          "experimenter": 101,
          "length": 12,
          "type": 65535
        }
      },
      {
        "OFPPortModPropExperimenter": {
          "data": [
            1
          ],
          "exp_type": 1,
          "experimenter": 101,
          "length": 16,
          "type": 65535
        }
      }
    ]
  }
}

```

```

    }
  },
  {
    "OFPPortModPropExperimenter": {
      "data": [
        1,
        2
      ],
      "exp_type": 2,
      "experimenter": 101,
      "length": 20,
      "type": 65535
    }
  }
]
}

```

class ryu.ofproto.ofproto_v1_5_parser.**OFPMeterMod**(datapath, command=0, flags=1, meter_id=1, bands=None)

Meter modification message

The controller sends this message to modify the meter.

Attribute	Description
command	One of the following values. OFPMC_ADD OFPMC_MODIFY OFPMC_DELETE
flags	Bitmap of the following flags. OFPMF_KBPS OFPMF_PKTPTS OFPMF_BURST OFPMF_STATS
meter_id	Meter instance
bands	list of the following class instance. OFPMeterBandDrop OFPMeterBandDscpRemark OFPMeterBandExperimenter

JSON Example:

```

{
  "OFPMeterMod": {
    "bands": [
      {
        "OFPMeterBandDrop": {
          "burst_size": 10,
          "len": 16,
          "rate": 1000,
          "type": 1
        }
      }
    ]
  }
}

```



```

    }
  },
  {
    "OFPMeterBandDscpRemark": {
      "burst_size": 10,
      "len": 16,
      "prec_level": 1,
      "rate": 1000,
      "type": 2
    }
  }
],
"command": 0,
"flags": 14,
"meter_id": 100
}
}

```

Multipart Messages

class ryu.ofproto.ofproto_v1_5_parser.OFPDescStatsRequest (datapath, flags=0, type=None)

Description statistics request message

The controller uses this message to query description of the switch.

Attribute	Description
flags	Zero or OFPMPF_REQ_MORE

Example:

```

def send_desc_stats_request(self, datapath):
    ofp_parser = datapath.ofproto_parser

    req = ofp_parser.OFPDescStatsRequest(datapath, 0)
    datapath.send_msg(req)

```

JSON Example:

```

{
  "OFPDescStatsRequest": {
    "flags": 0,
    "type": 0
  }
}

```

class ryu.ofproto.ofproto_v1_5_parser.OFPDescStatsReply (datapath, type=None, **kwargs)

Description statistics reply message

The switch responds with this message to a description statistics request.

Attribute	Description
body	Instance of OFPDescStats

Example:

```

@set_ev_cls(ofp_event.EventOFPDescStatsReply, MAIN_DISPATCHER)
def desc_stats_reply_handler(self, ev):

```

```

body = ev.msg.body

self.logger.debug('DescStats: mfr_desc=%s hw_desc=%s sw_desc=%s '
                  'serial_num=%s dp_desc=%s',
                  body.mfr_desc, body.hw_desc, body.sw_desc,
                  body.serial_num, body.dp_desc)

```

JSON Example:

```

{
  "OFPPDescStatsReply": {
    "body": {
      "OFPPDescStats": {
        "dp_desc": "dp",
        "hw_desc": "hw",
        "mfr_desc": "mfr",
        "serial_num": "serial",
        "sw_desc": "sw"
      }
    },
    "flags": 0,
    "type": 0
  }
}

```

class ryu.ofproto.ofproto_v1_5_parser.**OFPPFlowDescStatsRequest** (*datapath*, *flags=0*, *table_id=255*, *out_port=4294967295*, *out_group=4294967295*, *cookie=0*, *cookie_mask=0*, *match=None*, *type_=None*)

Individual flow descriptions request message

The controller uses this message to query individual flow descriptions.

Attribute	Description
flags	Zero or OFPPMPF_REQ_MORE
table_id	ID of table to read
out_port	Require matching entries to include this as an output port
out_group	Require matching entries to include this as an output group
cookie	Require matching entries to contain this cookie value
cookie_mask	Mask used to restrict the cookie bits that must match
match	Instance of OFPMatch

Example:

```

def send_flow_desc_request(self, datapath):
    ofp = datapath.ofproto
    ofp_parser = datapath.ofproto_parser

    cookie = cookie_mask = 0
    match = ofp_parser.OFPMatch(in_port=1)
    req = ofp_parser.OFPPFlowDescStatsRequest(datapath, 0,
                                              ofp.OFPTT_ALL,
                                              ofp.OFPP_ANY,
                                              ofp.OFPG_ANY,
                                              cookie, cookie_mask,

```

```
datapath.send_msg(req)
```

```
match)
```

JSON Example:

```
{
  "OFPPFlowDescStatsRequest": {
    "cookie": 1234605616436508552,
    "cookie_mask": 18446744073709551615,
    "flags": 0,
    "match": {
      "OFPMatch": {
        "length": 12,
        "oxm_fields": [
          {
            "OXMTlv": {
              "field": "in_port",
              "mask": null,
              "value": 1
            }
          }
        ],
        "type": 1
      }
    },
    "out_group": 4294967295,
    "out_port": 4294967295,
    "table_id": 1,
    "type": 1
  }
}
```

```
class ryu.ofproto.ofproto_v1_5_parser.OFPFlowDescStatsReply(datapath, type_=None,
                                                             **kwargs)
```

Individual flow descriptions reply message

The switch responds with this message to an individual flow descriptions request.

Attribute	Description
body	List of OFPPFlowDesc instance

Example:

```
@set_ev_cls(ofp_event.EventOFPFlowDescStatsReply, MAIN_DISPATCHER)
def flow_desc_reply_handler(self, ev):
    flows = []
    for stat in ev.msg.body:
        flows.append('table_id=%s priority=%d '
                    'idle_timeout=%d hard_timeout=%d flags=0x%04x '
                    'importance=%d cookie=%d match=%s '
                    'stats=%s instructions=%s' %
                    (stat.table_id, stat.priority,
                     stat.idle_timeout, stat.hard_timeout,
                     stat.flags, stat.importance,
                     stat.cookie, stat.match,
                     stat.stats, stat.instructions))
    self.logger.debug('FlowDesc: %s', flows)
```

JSON Example:

```

{
  "OFPPFlowDescStatsReply": {
    "body": [
      {
        "OFPPFlowDesc": {
          "cookie": 1234605616436508552,
          "flags": 1,
          "hard_timeout": 255,
          "idle_timeout": 255,
          "importance": 43690,
          "instructions": [
            {
              "OFPIInstructionGotoTable": {
                "len": 8,
                "table_id": 2,
                "type": 1
              }
            }
          ],
          "length": 64,
          "match": {
            "OFPMatch": {
              "length": 12,
              "oxm_fields": [
                {
                  "OXMTlv": {
                    "field": "in_port",
                    "mask": null,
                    "value": 1
                  }
                }
              ],
              "type": 1
            }
          },
          "priority": 5,
          "stats": {
            "OFPStats": {
              "length": 12,
              "oxs_fields": [
                {
                  "OXSTlv": {
                    "field": "flow_count",
                    "value": 1
                  }
                }
              ]
            }
          },
          "table_id": 1
        }
      ]
    },
    "flags": 0,
    "type": 1
  }
}

```

```
class ryu.ofproto.ofproto_v1_5_parser.OFPFlowStatsRequest (datapath, flags=0,
                                                         table_id=255,
                                                         out_port=4294967295,
                                                         out_group=4294967295,
                                                         cookie=0, cookie_mask=0,
                                                         match=None,
                                                         type_=None)
```

Individual flow statistics request message

The controller uses this message to query individual flow statistics.

Attribute	Description
flags	Zero or OFPMPF_REQ_MORE
table_id	ID of table to read
out_port	Require matching entries to include this as an output port
out_group	Require matching entries to include this as an output group
cookie	Require matching entries to contain this cookie value
cookie_mask	Mask used to restrict the cookie bits that must match
match	Instance of OFPMatch

Example:

```
def send_flow_stats_request(self, datapath):
    ofp = datapath.ofproto
    ofp_parser = datapath.ofproto_parser

    cookie = cookie_mask = 0
    match = ofp_parser.OFPMatch(in_port=1)
    req = ofp_parser.OFPFlowStatsRequest(datapath, 0,
                                         ofp.OFPTT_ALL,
                                         ofp.OFPP_ANY, ofp.OFPG_ANY,
                                         cookie, cookie_mask,
                                         match)

    datapath.send_msg(req)
```

JSON Example:

```
{
  "OFPFlowStatsRequest": {
    "cookie": 0,
    "cookie_mask": 0,
    "flags": 0,
    "match": {
      "OFPMatch": {
        "length": 4,
        "oxm_fields": [],
        "type": 1
      }
    },
    "out_group": 4294967295,
    "out_port": 4294967295,
    "table_id": 0,
    "type": 17
  }
}
```

```
class ryu.ofproto.ofproto_v1_5_parser.OFPFlowStatsReply (datapath, type_=None,
                                                         **kwargs)
```

Individual flow statistics reply message

The switch responds with this message to an individual flow statistics request.

Attribute	Description
body	List of OFPFlowStats instance

Example:

```
@set_ev_cls(ofp_event.EventOFPFlowStatsReply, MAIN_DISPATCHER)
def flow_stats_reply_handler(self, ev):
    flows = []
    for stat in ev.msg.body:
        flows.append('table_id=%s reason=%d priority=%d '
                    'match=%s stats=%s' %
                    (stat.table_id, stat.reason, stat.priority,
                     stat.match, stat.stats))
    self.logger.debug('FlowStats: %s', flows)
```

JSON Example:

```
{
  "OFPFlowStatsReply": {
    "body": [
      {
        "OFPFlowStats": {
          "length": 40,
          "match": {
            "OFPMatch": {
              "length": 12,
              "oxm_fields": [
                {
                  "OXMTlv": {
                    "field": "in_port",
                    "mask": null,
                    "value": 1
                  }
                }
              ],
              "type": 1
            }
          },
          "priority": 1,
          "reason": 0,
          "stats": {
            "OFPStats": {
              "length": 12,
              "oxs_fields": [
                {
                  "OXSTlv": {
                    "field": "flow_count",
                    "value": 1
                  }
                }
              ]
            }
          },
          "table_id": 1
        }
      ],
      "flags": 0,
```

```

        "type": 17
    }
}

```

```

class ryu.ofproto.ofproto_v1_5_parser.OFPAggregateStatsRequest (datapath, flags,
                                                                table_id, out_port,
                                                                out_group, cookie,
                                                                cookie_mask,
                                                                match,
                                                                type_=None)

```

Aggregate flow statistics request message

The controller uses this message to query aggregate flow statistics.

Attribute	Description
flags	Zero or OFPMPF_REQ_MORE
table_id	ID of table to read
out_port	Require matching entries to include this as an output port
out_group	Require matching entries to include this as an output group
cookie	Require matching entries to contain this cookie value
cookie_mask	Mask used to restrict the cookie bits that must match
match	Instance of OFPMatch

Example:

```

def send_aggregate_stats_request(self, datapath):
    ofp = datapath.ofproto
    ofp_parser = datapath.ofproto_parser

    cookie = cookie_mask = 0
    match = ofp_parser.OFPMatch(in_port=1)
    req = ofp_parser.OFPAggregateStatsRequest (datapath, 0,
                                              ofp.OFPTT_ALL,
                                              ofp.OFPP_ANY,
                                              ofp.OFPG_ANY,
                                              cookie, cookie_mask,
                                              match)

    datapath.send_msg(req)

```

JSON Example:

```

{
  "OFPAggregateStatsRequest": {
    "cookie": 0,
    "cookie_mask": 0,
    "flags": 0,
    "match": {
      "OFPMatch": {
        "length": 4,
        "oxm_fields": [],
        "type": 1
      }
    },
    "out_group": 4294967295,
    "out_port": 4294967295,
    "table_id": 255,
    "type": 2
  }
}

```

class ryu.ofproto.ofproto_v1_5_parser.OFPAggregateStatsReply (datapath, type_=None, **kwargs)

Aggregate flow statistics reply message

The switch responds with this message to an aggregate flow statistics request.

Attribute	Description
body	Instance of OFPAggregateStats

Example:

```
@set_ev_cls(ofp_event.EventOFPAggregateStatsReply, MAIN_DISPATCHER)
def aggregate_stats_reply_handler(self, ev):
    body = ev.msg.body

    self.logger.debug('AggregateStats: stats=%s', body.stats)
```

JSON Example:

```
{
  "OFPAggregateStatsReply": {
    "body": {
      "OFPAggregateStats": {
        "length": 16,
        "stats": {
          "OFPStats": {
            "length": 12,
            "oxs_fields": [
              {
                "OXSTlv": {
                  "field": "flow_count",
                  "value": 1
                }
              }
            ]
          }
        }
      }
    },
    "flags": 0,
    "type": 2
  }
}
```

class ryu.ofproto.ofproto_v1_5_parser.OFPPortStatsRequest (datapath, flags, port_no, type_=None)

Port statistics request message

The controller uses this message to query information about ports statistics.

Attribute	Description
flags	Zero or OFPMPF_REQ_MORE
port_no	Port number to read (OFPP_ANY to all ports)

Example:

```
def send_port_stats_request(self, datapath):
    ofp = datapath.ofproto
    ofp_parser = datapath.ofproto_parser
```



```
req = ofp_parser.OFPPortStatsRequest(datapath, 0, ofp.OFPP_ANY)
datapath.send_msg(req)
```

JSON Example:

```
{
  "OFPPortStatsRequest": {
    "flags": 0,
    "port_no": 4294967295,
    "type": 4
  }
}
```

```
class ryu.ofproto.ofproto_v1_5_parser.OFPPortStatsReply (datapath, type_=None,
**kwargs)
```

Port statistics reply message

The switch responds with this message to a port statistics request.

Attribute	Description
body	List of OFPPortStats instance

Example:

```
@set_ev_cls(ofp_event.EventOFPPortStatsReply, MAIN_DISPATCHER)
def port_stats_reply_handler(self, ev):
    ports = []
    for stat in ev.msg.body:
        ports.append(stat.length, stat.port_no,
                    stat.duration_sec, stat.duration_nsec,
                    stat.rx_packets, stat.tx_packets,
                    stat.rx_bytes, stat.tx_bytes,
                    stat.rx_dropped, stat.tx_dropped,
                    stat.rx_errors, stat.tx_errors,
                    repr(stat.properties))
    self.logger.debug('PortStats: %s', ports)
```

JSON Example:

```
{
  "OFPPortStatsReply": {
    "body": [
      {
        "OFPPortStats": {
          "duration_nsec": 0,
          "duration_sec": 0,
          "length": 224,
          "port_no": 7,
          "properties": [
            {
              "OFPPortStatsPropEthernet": {
                "collisions": 0,
                "length": 40,
                "rx_crc_err": 0,
                "rx_frame_err": 0,
                "rx_over_err": 0,
                "type": 0
              }
            }
          ]
        }
      }
    ]
  }
}
```

```

        "OFPPortStatsPropOptical": {
            "bias_current": 300,
            "flags": 3,
            "length": 44,
            "rx_freq_lmda": 1500,
            "rx_grid_span": 500,
            "rx_offset": 700,
            "rx_pwr": 2000,
            "temperature": 273,
            "tx_freq_lmda": 1500,
            "tx_grid_span": 500,
            "tx_offset": 700,
            "tx_pwr": 2000,
            "type": 1
        }
    },
    {
        "OFPPortStatsPropExperimenter": {
            "data": [],
            "exp_type": 0,
            "experimenter": 101,
            "length": 12,
            "type": 65535
        }
    },
    {
        "OFPPortStatsPropExperimenter": {
            "data": [
                1
            ],
            "exp_type": 1,
            "experimenter": 101,
            "length": 16,
            "type": 65535
        }
    },
    {
        "OFPPortStatsPropExperimenter": {
            "data": [
                1,
                2
            ],
            "exp_type": 2,
            "experimenter": 101,
            "length": 20,
            "type": 65535
        }
    }
],
"rx_bytes": 0,
"rx_dropped": 0,
"rx_errors": 0,
"rx_packets": 0,
"tx_bytes": 336,
"tx_dropped": 0,
"tx_errors": 0,
"tx_packets": 4
}

```

```

    },
    {
        "OFPPortStats": {
            "duration_nsec": 0,
            "duration_sec": 0,
            "length": 120,
            "port_no": 6,
            "properties": [
                {
                    "OFPPortStatsPropEthernet": {
                        "collisions": 0,
                        "length": 40,
                        "rx_crc_err": 0,
                        "rx_frame_err": 0,
                        "rx_over_err": 0,
                        "type": 0
                    }
                }
            ],
            "rx_bytes": 336,
            "rx_dropped": 0,
            "rx_errors": 0,
            "rx_packets": 4,
            "tx_bytes": 336,
            "tx_dropped": 0,
            "tx_errors": 0,
            "tx_packets": 4
        }
    },
    {
        "flags": 0,
        "type": 4
    }
}

```

class ryu.ofproto.ofproto_v1_5_parser.**OFPPortDescStatsRequest** (*datapath*, *flags=0*, *port_no=4294967295*, *type_=None*)

Port description request message

The controller uses this message to query description of one or all the ports.

Attribute	Description
flags	Zero or OFPMPF_REQ_MORE
port_no	Port number to read (OFPP_ANY to all ports)

Example:

```

def send_port_desc_stats_request(self, datapath):
    ofp = datapath.ofproto
    ofp_parser = datapath.ofproto_parser

    req = ofp_parser.OFPPortDescStatsRequest(datapath, 0, ofp.OFPP_ANY)
    datapath.send_msg(req)

```

JSON Example:

```

{
  "OFPPortDescStatsRequest": {
    "flags": 0,

```

```

        "port_no": 48346,
        "type": 13
    }
}

```

class ryu.ofproto.ofproto_v1_5_parser.**OFPPortDescStatsReply** (*datapath*, *type_=None*, ***kwargs*)

Port description reply message

The switch responds with this message to a port description request.

Attribute	Description
body	List of OFPPort instance

Example:

```

@set_ev_cls(ofp_event.EventOFPPortDescStatsReply, MAIN_DISPATCHER)
def port_desc_stats_reply_handler(self, ev):
    ports = []
    for p in ev.msg.body:
        ports.append('port_no=%d hw_addr=%s name=%s config=0x%08x '
                    'state=0x%08x properties=%s' %
                    (p.port_no, p.hw_addr,
                     p.name, p.config, p.state, repr(p.properties)))
    self.logger.debug('OFPPortDescStatsReply received: %s', ports)

```

JSON Example:

```

{
  "OFPPortDescStatsReply": {
    "body": [
      {
        "OFPPort": {
          "config": 0,
          "hw_addr": "f2:0b:a4:d0:3f:70",
          "length": 168,
          "name": "Port7",
          "port_no": 7,
          "properties": [
            {
              "OFPPortDescPropEthernet": {
                "advertised": 10240,
                "curr": 10248,
                "curr_speed": 5000,
                "length": 32,
                "max_speed": 5000,
                "peer": 10248,
                "supported": 10248,
                "type": 0
              }
            },
            {
              "OFPPortDescPropOptical": {
                "length": 40,
                "rx_grid_freq_lmda": 1500,
                "rx_max_freq_lmda": 2000,
                "rx_min_freq_lmda": 1000,
                "supported": 1,
                "tx_grid_freq_lmda": 1500,
                "tx_max_freq_lmda": 2000,

```

```

        "tx_min_freq_lmda": 1000,
        "tx_pwr_max": 2000,
        "tx_pwr_min": 1000,
        "type": 1
    }
},
{
    "OFPPortDescPropExperimenter": {
        "data": [],
        "exp_type": 0,
        "experimenter": 101,
        "length": 12,
        "type": 65535
    }
},
{
    "OFPPortDescPropExperimenter": {
        "data": [
            1
        ],
        "exp_type": 1,
        "experimenter": 101,
        "length": 16,
        "type": 65535
    }
},
{
    "OFPPortDescPropExperimenter": {
        "data": [
            1,
            2
        ],
        "exp_type": 2,
        "experimenter": 101,
        "length": 20,
        "type": 65535
    }
}
],
"state": 4
}
},
{
    "OFPPort": {
        "config": 0,
        "hw_addr": "f2:0b:a4:7d:f8:ea",
        "length": 72,
        "name": "Port6",
        "port_no": 6,
        "properties": [
            {
                "OFPPortDescPropEthernet": {
                    "advertised": 10240,
                    "curr": 10248,
                    "curr_speed": 5000,
                    "length": 32,
                    "max_speed": 5000,
                    "peer": 10248,

```

```

        "supported": 10248,
        "type": 0
    }
    ],
    "state": 4
}
]
"flags": 0,
"type": 13
}
}

```

```

class ryu.ofproto.ofproto_v1_5_parser.OFPQueueStatsRequest (datapath, flags=0,
                                                             port_no=4294967295,
                                                             queue_id=4294967295,
                                                             type_=None)

```

Queue statistics request message

The controller uses this message to query queue statistics.

Attribute	Description
flags	Zero or OFPMPF_REQ_MORE
port_no	Port number to read
queue_id	ID of queue to read

Example:

```

def send_queue_stats_request(self, datapath):
    ofp = datapath.ofproto
    ofp_parser = datapath.ofproto_parser

    req = ofp_parser.OFPQueueStatsRequest (datapath, 0, ofp.OFPP_ANY,
                                           ofp.OFPQ_ALL)

    datapath.send_msg(req)

```

JSON Example:

```

{
  "OFPQueueStatsRequest": {
    "flags": 0,
    "port_no": 43981,
    "queue_id": 4294967295,
    "type": 5
  }
}

```

```

class ryu.ofproto.ofproto_v1_5_parser.OFPQueueStatsReply (datapath, type_=None,
                                                           **kwargs)

```

Queue statistics reply message

The switch responds with this message to an aggregate flow statistics request.

Attribute	Description
body	List of OFPQueueStats instance

Example:

```

@set_ev_cls(ofp_event.EventOFPQueueStatsReply, MAIN_DISPATCHER)
def queue_stats_reply_handler(self, ev):

```

```

queues = []
for stat in ev.msg.body:
    queues.append('port_no=%d queue_id=%d '
                  'tx_bytes=%d tx_packets=%d tx_errors=%d '
                  'duration_sec=%d duration_nsec=%d'
                  'properties=%s' %
                  (stat.port_no, stat.queue_id,
                   stat.tx_bytes, stat.tx_packets, stat.tx_errors,
                   stat.duration_sec, stat.duration_nsec,
                   repr(stat.properties)))
self.logger.debug('QueueStats: %s', queues)

```

JSON Example:

```

{
  "OFPPQueueStatsReply": {
    "body": [
      {
        "OFPPQueueStats": {
          "duration_nsec": 0,
          "duration_sec": 0,
          "length": 104,
          "port_no": 7,
          "properties": [
            {
              "OFPPQueueStatsPropExperimenter": {
                "data": [],
                "exp_type": 0,
                "experimenter": 101,
                "length": 12,
                "type": 65535
              }
            },
            {
              "OFPPQueueStatsPropExperimenter": {
                "data": [
                  1
                ],
                "exp_type": 1,
                "experimenter": 101,
                "length": 16,
                "type": 65535
              }
            },
            {
              "OFPPQueueStatsPropExperimenter": {
                "data": [
                  1,
                  2
                ],
                "exp_type": 2,
                "experimenter": 101,
                "length": 20,
                "type": 65535
              }
            }
          ],
          "queue_id": 1,

```

```

        "tx_bytes": 0,
        "tx_errors": 0,
        "tx_packets": 0
    }
},
{
    "OFPQueueStats": {
        "duration_nsec": 0,
        "duration_sec": 0,
        "length": 48,
        "port_no": 6,
        "properties": [],
        "queue_id": 1,
        "tx_bytes": 0,
        "tx_errors": 0,
        "tx_packets": 0
    }
},
{
    "OFPQueueStats": {
        "duration_nsec": 0,
        "duration_sec": 0,
        "length": 48,
        "port_no": 7,
        "properties": [],
        "queue_id": 2,
        "tx_bytes": 0,
        "tx_errors": 0,
        "tx_packets": 0
    }
}
],
"flags": 0,
"type": 5
}
}

```

```

class ryu.ofproto.ofproto_v1_5_parser.OFPQueueDescStatsRequest (datapath, flags=0,
                                                                port_no=4294967295,
                                                                queue_id=4294967295,
                                                                type_=None)

```

Queue description request message

The controller uses this message to query description of all the queues.

Attribute	Description
flags	Zero or OFPMPF_REQ_MORE
port_no	Port number to read (OFPP_ANY for all ports)
queue_id	ID of queue to read (OFPQ_ALL for all queues)

Example:

```

def send_queue_desc_stats_request(self, datapath):
    ofp = datapath.ofproto
    ofp_parser = datapath.ofproto_parser

    req = ofp_parser.OFPQueueDescStatsRequest (datapath, 0,
                                                ofp.OFPP_ANY,
                                                ofp.OFPQ_ALL)

```



```
datapath.send_msg(req)
```

JSON Example:

```
{
  "OFPQueueDescStatsRequest": {
    "flags": 0,
    "port_no": 52651,
    "queue_id": 57020,
    "type": 15
  }
}
```

class ryu.ofproto.ofproto_v1_5_parser.OFPQueueDescStatsReply (datapath, type_=None, **kwargs)

Queue description reply message

The switch responds with this message to a queue description request.

Attribute	Description
body	List of OFPQueueDesc instance

Example:

```
@set_ev_cls(ofp_event.EventOFPQueueDescStatsReply, MAIN_DISPATCHER)
def queue_desc_stats_reply_handler(self, ev):
    queues = []
    for q in ev.msg.body:
        queues.append('port_no=%d queue_id=0x%08x properties=%s' %
                      (q.port_no, q.queue_id, repr(q.properties)))
    self.logger.debug('OFPQueueDescStatsReply received: %s', queues)
```

JSON Example:

```
{
  "OFPQueueDescStatsReply": {
    "body": [
      {
        "OFPQueueDesc": {
          "len": 32,
          "port_no": 7,
          "properties": [
            {
              "OFPQueueDescPropExperimenter": {
                "data": [],
                "exp_type": 0,
                "experimenter": 101,
                "length": 12,
                "type": 65535
              }
            }
          ],
          "queue_id": 0
        }
      },
      {
        "OFPQueueDesc": {
          "len": 88,
          "port_no": 8,
          "properties": [
```

```

        {
            "OFFQueueDescPropMinRate": {
                "length": 8,
                "rate": 300,
                "type": 1
            }
        },
        {
            "OFFQueueDescPropMaxRate": {
                "length": 8,
                "rate": 900,
                "type": 2
            }
        },
        {
            "OFFQueueDescPropExperimenter": {
                "data": [],
                "exp_type": 0,
                "experimenter": 101,
                "length": 12,
                "type": 65535
            }
        },
        {
            "OFFQueueDescPropExperimenter": {
                "data": [
                    1
                ],
                "exp_type": 1,
                "experimenter": 101,
                "length": 16,
                "type": 65535
            }
        },
        {
            "OFFQueueDescPropExperimenter": {
                "data": [
                    1,
                    2
                ],
                "exp_type": 2,
                "experimenter": 101,
                "length": 20,
                "type": 65535
            }
        }
    ],
    "queue_id": 1
}
}
"flags": 0,
"type": 15
}
}

```

```
class ryu.ofproto.ofproto_v1_5_parser.OFPGGroupStatsRequest (datapath, flags=0,
                                                            group_id=4294967292,
                                                            type_=None)
```

Group statistics request message

The controller uses this message to query statistics of one or more groups.

Attribute	Description
flags	Zero or OFPMPPF_REQ_MORE
group_id	ID of group to read (OFPG_ALL to all groups)

Example:

```
def send_group_stats_request(self, datapath):
    ofp = datapath.ofproto
    ofp_parser = datapath.ofproto_parser

    req = ofp_parser.OFPGGroupStatsRequest(datapath, 0, ofp.OFPG_ALL)
    datapath.send_msg(req)
```

JSON Example:

```
{
  "OFPGGroupStatsRequest": {
    "flags": 0,
    "group_id": 4294967292,
    "type": 6
  }
}
```

```
class ryu.ofproto.ofproto_v1_5_parser.OFPGGroupStatsReply (datapath, type_=None,
                                                            **kwargs)
```

Group statistics reply message

The switch responds with this message to a group statistics request.

Attribute	Description
body	List of OFPGGroupStats instance

Example:

```
@set_ev_cls(ofp_event.EventOFPGGroupStatsReply, MAIN_DISPATCHER)
def group_stats_reply_handler(self, ev):
    groups = []
    for stat in ev.msg.body:
        groups.append('length=%d group_id=%d '
                     'ref_count=%d packet_count=%d byte_count=%d '
                     'duration_sec=%d duration_nsec=%d' %
                     (stat.length, stat.group_id,
                      stat.ref_count, stat.packet_count,
                      stat.byte_count, stat.duration_sec,
                      stat.duration_nsec))
    self.logger.debug('GroupStats: %s', groups)
```

JSON Example:

```
{
  "OFPGGroupStatsReply": {
    "body": [
      {
        "OFPGGroupStats": {
          "bucket_stats": [
```

```

        {
            "OFPPacketCounter": {
                "byte_count": 2345,
                "packet_count": 234
            }
        },
        {
            "byte_count": 12345,
            "duration_nsec": 609036000,
            "duration_sec": 9,
            "group_id": 1,
            "length": 56,
            "packet_count": 123,
            "ref_count": 2
        }
    ],
    "flags": 0,
    "type": 6
}

```

class ryu.ofproto.ofproto_v1_5_parser.OFPGGroupDescStatsRequest (datapath, flags=0, group_id=4294967292, type=None)

Group description request message

The controller uses this message to list the set of groups on a switch.

Attribute	Description
flags	Zero or OFPPMPF_REQ_MORE
group_id	ID of group to read (OFPG_ALL to all groups)

Example:

```

def send_group_desc_stats_request(self, datapath):
    ofp = datapath.ofproto
    ofp_parser = datapath.ofproto_parser

    req = ofp_parser.OFPGGroupDescStatsRequest (datapath, 0, ofp.OFPG_ALL)
    datapath.send_msg(req)

```

JSON Example:

```

{
  "OFPGGroupDescStatsRequest": {
    "flags": 0,
    "group_id": 52651,
    "type": 7
  }
}

```

class ryu.ofproto.ofproto_v1_5_parser.OFPGGroupDescStatsReply (datapath, type=None, **kwargs)

Group description reply message

The switch responds with this message to a group description request.

Attribute	Description
body	List of OFPGGroupDescStats instance

Example:

```
@set_ev_cls(ofp_event.EventOFPGroupDescStatsReply, MAIN_DISPATCHER)
def group_desc_stats_reply_handler(self, ev):
    desc = []
    for stat in ev.msg.body:
        desc.append('length=%d type=%d group_id=%d '
                   'buckets=%s properties=%s' %
                   (stat.length, stat.type, stat.group_id,
                    stat.bucket, repr(stat.properties)))
    self.logger.debug('GroupDescStats: %s', desc)
```

JSON Example:

```
{
  "OFPGroupDescStatsReply": {
    "body": [
      {
        "OFPGroupDescStats": {
          "bucket_array_len": 32,
          "buckets": [
            {
              "OFPBucket": {
                "action_array_len": 16,
                "actions": [
                  {
                    "OFPActionOutput": {
                      "len": 16,
                      "max_len": 65509,
                      "port": 1,
                      "type": 0
                    }
                  }
                ],
                "bucket_id": 65535,
                "len": 32,
                "properties": [
                  {
                    "OFPGroupBucketPropWeight": {
                      "length": 8,
                      "type": 0,
                      "weight": 65535
                    }
                  }
                ]
              }
            }
          ],
          "group_id": 1,
          "length": 48,
          "properties": [],
          "type": 1
        }
      ],
      "flags": 0,
      "type": 7
    }
  }
}
```

```
class ryu.ofproto.ofproto_v1_5_parser.OFPGroupFeaturesStatsRequest (datapath,
                                                                    flags=0,
                                                                    type_=None)
```

Group features request message

The controller uses this message to list the capabilities of groups on a switch.

Attribute	Description
flags	Zero or OFPMPF_REQ_MORE

Example:

```
def send_group_features_stats_request(self, datapath):
    ofp_parser = datapath.ofproto_parser

    req = ofp_parser.OFPGroupFeaturesStatsRequest(datapath, 0)
    datapath.send_msg(req)
```

JSON Example:

```
{
  "OFPGroupFeaturesStatsRequest": {
    "flags": 0,
    "type": 8
  }
}
```

```
class ryu.ofproto.ofproto_v1_5_parser.OFPGroupFeaturesStatsReply (datapath,
                                                                    type_=None,
                                                                    **kwargs)
```

Group features reply message

The switch responds with this message to a group features request.

Attribute	Description
body	Instance of OFPGroupFeaturesStats

Example:

```
@set_ev_cls(ofp_event.EventOFPGroupFeaturesStatsReply, MAIN_DISPATCHER)
def group_features_stats_reply_handler(self, ev):
    body = ev.msg.body

    self.logger.debug('GroupFeaturesStats: types=%d '
                      'capabilities=0x%08x max_groups=%s '
                      'actions=%s',
                      body.types, body.capabilities,
                      body.max_groups, body.actions)
```

JSON Example:

```
{
  "OFPGroupFeaturesStatsReply": {
    "body": {
      "OFPGroupFeaturesStats": {
        "actions": [
          67082241,
          67082241,
          67082241,
          67082241
        ],
        "capabilities": 5,

```

```

        "max_groups": [
            16777216,
            16777216,
            16777216,
            16777216
        ],
        "types": 15
    }
},
"flags": 0,
"type": 8
}
}

```

class ryu.ofproto.ofproto_v1_5_parser.**OFPMeterStatsRequest** (datapath, flags=0, meter_id=4294967295, type_=None)

Meter statistics request message

The controller uses this message to query statistics for one or more meters.

Attribute	Description
flags	Zero or OFPMPF_REQ_MORE
meter_id	ID of meter to read (OFPM_ALL to all meters)

Example:

```

def send_meter_stats_request(self, datapath):
    ofp = datapath.ofproto
    ofp_parser = datapath.ofproto_parser

    req = ofp_parser.OFPMeterStatsRequest(datapath, 0, ofp.OFPM_ALL)
    datapath.send_msg(req)

```

JSON Example:

```

{
  "OFPMeterStatsRequest": {
    "flags": 0,
    "meter_id": 4294967295,
    "type": 9
  }
}

```

class ryu.ofproto.ofproto_v1_5_parser.**OFPMeterStatsReply** (datapath, type_=None, **kwargs)

Meter statistics reply message

The switch responds with this message to a meter statistics request.

Attribute	Description
body	List of OFPMeterStats instance

Example:

```

@set_ev_cls(ofp_event.EventOFPMeterStatsReply, MAIN_DISPATCHER)
def meter_stats_reply_handler(self, ev):
    meters = []
    for stat in ev.msg.body:
        meters.append('meter_id=0x%08x len=%d ref_count=%d '
                     'packet_in_count=%d byte_in_count=%d '

```

```

        'duration_sec=%d duration_nsec=%d '
        'band_stats=%s' %
        (stat.meter_id, stat.len, stat.ref_count,
         stat.packet_in_count, stat.byte_in_count,
         stat.duration_sec, stat.duration_nsec,
         stat.band_stats))
    self.logger.debug('MeterStats: %s', meters)

```

JSON Example:

```

{
  "OFPMeterStatsReply": {
    "body": [
      {
        "OFPMeterStats": {
          "band_stats": [
            {
              "OFPMeterBandStats": {
                "byte_band_count": 0,
                "packet_band_count": 0
              }
            }
          ],
          "byte_in_count": 0,
          "duration_nsec": 480000,
          "duration_sec": 0,
          "ref_count": 0,
          "len": 56,
          "meter_id": 100,
          "packet_in_count": 0
        }
      }
    ],
    "flags": 0,
    "type": 9
  }
}

```

```

class ryu.ofproto.ofproto_v1_5_parser.OFPMeterDescStatsRequest (datapath,
                                                                flags=0, meter_id=4294967295,
                                                                type_=None)

```

Meter description statistics request message

The controller uses this message to query configuration for one or more meters.

Attribute	Description
flags	Zero or OFPMPF_REQ_MORE
meter_id	ID of meter to read (OFPM_ALL to all meters)

Example:

```

def send_meter_desc_stats_request(self, datapath):
    ofp = datapath.ofproto
    ofp_parser = datapath.ofproto_parser

    req = ofp_parser.OFPMeterDescStatsRequest (datapath, 0,
                                                ofp.OFPM_ALL)

    datapath.send_msg(req)

```

JSON Example:

```
{
  "OFPMeterDescStatsRequest": {
    "flags": 0,
    "meter_id": 4294967295,
    "type": 10
  }
}
```

class ryu.ofproto.ofproto_v1_5_parser.**OFPMeterDescStatsReply** (*datapath*, *type_=None*, ***kwargs*)

Meter description statistics reply message

The switch responds with this message to a meter description statistics request.

Attribute	Description
body	List of OFPMeterDescStats instance

Example:

```
@set_ev_cls(ofp_event.EventOFPMeterDescStatsReply, MAIN_DISPATCHER)
def meter_desc_stats_reply_handler(self, ev):
    configs = []
    for stat in ev.msg.body:
        configs.append('length=%d flags=0x%04x meter_id=0x%08x '
                      'bands=%s' %
                      (stat.length, stat.flags, stat.meter_id,
                       stat.bands))
    self.logger.debug('MeterDescStats: %s', configs)
```

JSON Example:

```
{
  "OFPMeterDescStatsReply": {
    "body": [
      {
        "OFPMeterDescStats": {
          "bands": [
            {
              "OFPMeterBandDrop": {
                "burst_size": 10,
                "len": 16,
                "rate": 1000,
                "type": 1
              }
            }
          ],
          "flags": 14,
          "length": 24,
          "meter_id": 100
        }
      },
      {
        "flags": 0,
        "type": 10
      }
    ]
  }
}
```

```
class ryu.ofproto.ofproto_v1_5_parser.OFPMeterFeaturesStatsRequest (datapath,
                                                                    flags=0,
                                                                    type_=None)
```

Meter features statistics request message

The controller uses this message to query the set of features of the metering subsystem.

Attribute	Description
flags	Zero or OFPMPF_REQ_MORE

Example:

```
def send_meter_features_stats_request(self, datapath):
    ofp_parser = datapath.ofproto_parser

    req = ofp_parser.OFPMeterFeaturesStatsRequest(datapath, 0)
    datapath.send_msg(req)
```

JSON Example:

```
{
  "OFPMeterFeaturesStatsRequest": {
    "flags": 0,
    "type": 11
  }
}
```

```
class ryu.ofproto.ofproto_v1_5_parser.OFPMeterFeaturesStatsReply (datapath,
                                                                    type_=None,
                                                                    **kwargs)
```

Meter features statistics reply message

The switch responds with this message to a meter features statistics request.

Attribute	Description
body	List of OFPMeterFeaturesStats instance

Example:

```
@set_ev_cls(ofp_event.EventOFPMeterFeaturesStatsReply, MAIN_DISPATCHER)
def meter_features_stats_reply_handler(self, ev):
    features = []
    for stat in ev.msg.body:
        features.append('max_meter=%d band_types=0x%08x '
                       'capabilities=0x%08x max_bands=%d '
                       'max_color=%d' %
                       (stat.max_meter, stat.band_types,
                        stat.capabilities, stat.max_bands,
                        stat.max_color))
    self.logger.debug('MeterFeaturesStats: %s', features)
```

JSON Example:

```
{
  "OFPMeterFeaturesStatsReply": {
    "body": [
      {
        "OFPMeterFeaturesStats": {
          "band_types": 2147483654,
          "capabilities": 15,
          "features": 3,
          "max_bands": 255,

```

```

        "max_color": 0,
        "max_meter": 16777216
    }
    ],
    "flags": 0,
    "type": 11
}
}

```

class ryu.ofproto.ofproto_v1_5_parser.**OFPControllerStatusStatsRequest** (*datapath*, *flags=0*, *type_=None*)

Controller status multipart request message

The controller uses this message to request the status, the roles and the control channels of other controllers configured on the switch.

Attribute	Description
flags	Zero or OFPMPF_REQ_MORE

Example:

```

def send_controller_status_multipart_request(self, datapath):
    ofp_parser = datapath.ofproto_parser

    req = ofp_parser.OFPPortDescStatsRequest(datapath, 0)
    datapath.send_msg(req)

```

JSON Example:

```

{
  "OFPControllerStatusStatsRequest": {
    "flags": 0,
    "type": 18
  }
}

```

class ryu.ofproto.ofproto_v1_5_parser.**OFPControllerStatusStatsReply** (*datapath*, *type_=None*, ***kwargs*)

Controller status multipart reply message

The switch responds with this message to a controller status multipart request.

Attribute	Description
body	List of OFPControllerStatus instance

Example:

```

@set_ev_cls(ofp_event.EventOFPControllerStatusStatsReply,
            MAIN_DISPATCHER)
def controller_status_multipart_reply_handler(self, ev):
    status = []
    for s in ev.msg.body:
        status.append('short_id=%d role=%d reason=%d '
                     'channel_status=%d properties=%s' %
                     (s.short_id, s.role, s.reason,
                      s.channel_status, repr(s.properties)))

```

```
self.logger.debug('OFPControllerStatusStatsReply received: %s',
                  status)
```

JSON Example:

```
{
  "OFPControllerStatusStatsReply": {
    "body": [
      {
        "OFPControllerStatusStats": {
          "channel_status": 1,
          "length": 48,
          "properties": [
            {
              "OFPControllerStatusPropUri": {
                "length": 26,
                "type": 0,
                "uri": "tls:192.168.34.23:6653"
              }
            }
          ],
          "reason": 1,
          "role": 1,
          "short_id": 65535
        }
      }
    ],
    "flags": 0,
    "type": 18
  }
}
```

class ryu.ofproto.ofproto_v1_5_parser.**OFPTableStatsRequest** (*datapath*, *flags*, *type_=None*)

Table statistics request message

The controller uses this message to query flow table statistics.

Attribute	Description
flags	Zero or OFPMPF_REQ_MORE

Example:

```
def send_table_stats_request(self, datapath):
    ofp_parser = datapath.ofproto_parser

    req = ofp_parser.OFPTableStatsRequest(datapath, 0)
    datapath.send_msg(req)
```

JSON Example:

```
{
  "OFPTableStatsRequest": {
    "flags": 0,
    "type": 3
  }
}
```

class ryu.ofproto.ofproto_v1_5_parser.**OFPTableStatsReply** (*datapath*, *type_=None*, ***kwargs*)

Table statistics reply message

The switch responds with this message to a table statistics request.

Attribute	Description
body	List of OFPTableStats instance

Example:

```
@set_ev_cls(ofp_event.EventOFPTableStatsReply, MAIN_DISPATCHER)
def table_stats_reply_handler(self, ev):
    tables = []
    for stat in ev.msg.body:
        tables.append('table_id=%d active_count=%d lookup_count=%d '
                    ' matched_count=%d' %
                    (stat.table_id, stat.active_count,
                     stat.lookup_count, stat.matched_count))
    self.logger.debug('TableStats: %s', tables)
```

JSON Example:

```
{
  "OFPTableStatsReply": {
    "body": [
      {
        "OFPTableStats": {
          "active_count": 4,
          "lookup_count": 4,
          "matched_count": 4,
          "table_id": 0
        }
      },
      {
        "OFPTableStats": {
          "active_count": 4,
          "lookup_count": 4,
          "matched_count": 4,
          "table_id": 1
        }
      }
    ],
    "flags": 0,
    "type": 3
  }
}
```

```
class ryu.ofproto.ofproto_v1_5_parser.OFPTableDescStatsRequest (datapath, flags=0,
                                                                type_=None)
```

Table description request message

The controller uses this message to query description of all the tables.

Attribute	Description
flags	Zero or OFPMPF_REQ_MORE

Example:

```
def send_table_desc_stats_request(self, datapath):
    ofp_parser = datapath.ofproto_parser

    req = ofp_parser.OFPTableDescStatsRequest(datapath, 0)
    datapath.send_msg(req)
```

JSON Example:

```
{
  "OFPTableDescStatsRequest": {
    "flags": 0,
    "type": 14
  }
}
```

`class ryu.ofproto.ofproto_v1_5_parser.OFPTableDescStatsReply` (*datapath*, *type_=None*, ***kwargs*)

Table description reply message

The switch responds with this message to a table description request.

Attribute	Description
body	List of OFPTableDesc instance

Example:

```
@set_ev_cls(ofp_event.EventOFPTableDescStatsReply, MAIN_DISPATCHER)
def table_desc_stats_reply_handler(self, ev):
    tables = []
    for p in ev.msg.body:
        tables.append('table_id=%d config=0x%08x properties=%s' %
                     (p.table_id, p.config, repr(p.properties)))
    self.logger.debug('OFPTableDescStatsReply received: %s', tables)
```

JSON Example:

```
{
  "OFPTableDescStatsReply": {
    "body": [
      {
        "OFPTableDesc": {
          "config": 0,
          "length": 24,
          "properties": [
            {
              "OFPTableModPropExperimenter": {
                "data": [],
                "exp_type": 0,
                "experimenter": 101,
                "length": 12,
                "type": 65535
              }
            }
          ],
          "table_id": 7
        }
      },
      {
        "OFPTableDesc": {
          "config": 0,
          "length": 80,
          "properties": [
            {
              "OFPTableModPropEviction": {
                "flags": 0,
                "length": 8,
                "type": 2
              }
            }
          ]
        }
      }
    ]
  }
}
```

```

    },
    {
      "OFPTableModPropVacancy": {
        "length": 8,
        "type": 3,
        "vacancy": 0,
        "vacancy_down": 0,
        "vacancy_up": 0
      }
    },
    {
      "OFPTableModPropExperimenter": {
        "data": [],
        "exp_type": 0,
        "experimenter": 101,
        "length": 12,
        "type": 65535
      }
    },
    {
      "OFPTableModPropExperimenter": {
        "data": [
          1
        ],
        "exp_type": 1,
        "experimenter": 101,
        "length": 16,
        "type": 65535
      }
    },
    {
      "OFPTableModPropExperimenter": {
        "data": [
          1,
          2
        ],
        "exp_type": 2,
        "experimenter": 101,
        "length": 20,
        "type": 65535
      }
    }
  ],
  "table_id": 8
}
},
"flags": 0,
"type": 14
}
}

```

class ryu.ofproto.ofproto_v1_5_parser.**OFPTableFeaturesStatsRequest** (*datapath*,
flags=0,
body=None,
type_=None)

Table features statistics request message

The controller uses this message to query table features.

Attribute	Description
body	List of OFPTableFeaturesStats instances. The default is [].

JSON Example:

```
{
  "OFPTableFeaturesStatsRequest": {
    "body": [
      {
        "OFPTableFeaturesStats": {
          "capabilities": 4,
          "command": 1,
          "features": 1,
          "length": 80,
          "max_entries": 255,
          "metadata_match": 18446744073709551615,
          "metadata_write": 18446744073709551615,
          "name": "table1",
          "properties": [
            {
              "OFPTableFeaturePropOxmValues": {
                "length": 14,
                "oxm_values": [
                  {
                    "OXMTlv": {
                      "field": "eth_src",
                      "mask": null,
                      "value": "aa:bb:cc:dd:ee:ff"
                    }
                  }
                ],
                "type": 22
              }
            }
          ],
          "table_id": 1
        }
      ],
      "flags": 0,
      "type": 12
    }
  }
}
```

```
class ryu.ofproto.ofproto_v1_5_parser.OFPTableFeaturesStatsReply (datapath,
                                                                    type_=None,
                                                                    **kwargs)
```

Table features statistics reply message

The switch responds with this message to a table features statistics request.

Attribute	Description
body	List of OFPTableFeaturesStats instance

JSON Example:

```
{
  "OFPTableFeaturesStatsReply": {
    "body": [
```



```

    {
      "OFPTableFeaturesStats": {
        "capabilities": 4,
        "command": 1,
        "features": 1,
        "length": 80,
        "max_entries": 255,
        "metadata_match": 18446744073709551615,
        "metadata_write": 18446744073709551615,
        "name": "table1",
        "properties": [
          {
            "OFPTableFeaturePropOxmValues": {
              "length": 14,
              "oxm_values": [
                {
                  "OXMTlv": {
                    "field": "eth_src",
                    "mask": null,
                    "value": "aa:bb:cc:dd:ee:ff"
                  }
                }
              ],
              "type": 22
            }
          }
        ],
        "table_id": 1
      }
    },
    "flags": 0,
    "type": 12
  }
}

```

```

class ryu.ofproto.ofproto_v1_5_parser.OFPFlowMonitorRequest (datapath,
                                                              flags=0,
                                                              monitor_id=0,
                                                              out_port=4294967295,
                                                              out_group=4294967295,
                                                              monitor_flags=0,
                                                              table_id=255,
                                                              command=0,
                                                              match=None,
                                                              type_=None)

```

Flow monitor request message

The controller uses this message to query flow monitors.

Attribute	Description
flags	Zero or <code>OFPPMF_REQ_MORE</code>
monitor_id	Controller-assigned ID for this monitor
out_port	Require matching entries to include this as an output port
out_group	Require matching entries to include this as an output group
monitor_flags	Bitmap of the following flags. <code>OFPPMF_INITIAL</code> <code>OFPPMF_ADD</code> <code>OFPPMF_REMOVED</code> <code>OFPPMF_MODIFY</code> <code>OFPPMF_INSTRUCTIONS</code> <code>OFPPMF_NO_ABBREV</code> <code>OFPPMF_ONLY_OWN</code>
table_id	ID of table to monitor
command	One of the following values. <code>OFPPMC_ADD</code> <code>OFPPMC_MODIFY</code> <code>OFPPMC_DELETE</code>
match	Instance of <code>OFPPMatch</code>

Example:

```
def send_flow_monitor_request(self, datapath):
    ofp = datapath.ofproto
    ofp_parser = datapath.ofproto_parser

    monitor_flags = [ofp.OFPPMF_INITIAL, ofp.OFPPMF_ONLY_OWN]
    match = ofp_parser.OFPPMatch(in_port=1)
    req = ofp_parser.OFPPFlowMonitorRequest(datapath, 0, 10000,
                                             ofp.OFPP_ANY, ofp.OFPG_ANY,
                                             monitor_flags,
                                             ofp.OFPTT_ALL,
                                             ofp.OFPPMC_ADD, match)

    datapath.send_msg(req)
```

JSON Example:

```
{
  "OFPPFlowMonitorRequest": {
    "command": 0,
    "flags": 0,
    "match": {
      "OFPPMatch": {
        "length": 14,
        "oxm_fields": [
          {
            "OXMTlv": {
              "field": "eth_dst",
              "mask": null,
              "value": "f2:0b:a4:7d:f8:ea"
            }
          }
        ]
      }
    }
  }
}
```

```

        }
    },
    ],
    "type": 1
}
},
"monitor_flags": 15,
"monitor_id": 100000000,
"out_group": 4294967295,
"out_port": 22,
"table_id": 33,
"type": 16
}
}

```

class ryu.ofproto.ofproto_v1_5_parser.**OFPPFlowMonitorReply** (*datapath*, *type_=None*, ***kwargs*)

Flow monitor reply message

The switch responds with this message to a flow monitor request.

Attribute	Description
body	List of list of the following class instance. OFPPFlowMonitorFull OFPPFlowMonitorAbbrev OFPPFlowMonitorPaused

Example:

```

@set_ev_cls(ofp_event.EventOFPPFlowMonitorReply, MAIN_DISPATCHER)
def flow_monitor_reply_handler(self, ev):
    msg = ev.msg
    dp = msg.datapath
    ofp = dp.ofproto
    flow_updates = []

    for update in msg.body:
        update_str = 'length=%d event=%d' %
                    (update.length, update.event)
        if (update.event == ofp.OFPFME_INITIAL or
            update.event == ofp.OFPFME_ADDED or
            update.event == ofp.OFPFME_REMOVED or
            update.event == ofp.OFPFME_MODIFIED):
            update_str += 'table_id=%d reason=%d idle_timeout=%d '
                        'hard_timeout=%d priority=%d cookie=%d '
                        'match=%d instructions=%s' %
                        (update.table_id, update.reason,
                         update.idle_timeout, update.hard_timeout,
                         update.priority, update.cookie,
                         update.match, update.instructions)
        elif update.event == ofp.OFPFME_ABBREV:
            update_str += 'xid=%d' % (update.xid)
        flow_updates.append(update_str)
    self.logger.debug('FlowUpdates: %s', flow_updates)

```

JSON Example:

```

{
  "OFPPFlowMonitorReply": {
    "body": [
      {
        "OFPPFlowUpdateFull": {
          "cookie": 0,
          "event": 0,
          "hard_timeout": 700,
          "idle_timeout": 600,
          "instructions": [
            {
              "OFPIInstructionActions": {
                "actions": [
                  {
                    "OFPAActionOutput": {
                      "len": 16,
                      "max_len": 0,
                      "port": 4294967290,
                      "type": 0
                    }
                  }
                ],
                "len": 24,
                "type": 4
              }
            }
          ],
          "length": 64,
          "match": {
            "OFPMatch": {
              "length": 10,
              "oxm_fields": [
                {
                  "OXMTlv": {
                    "field": "eth_type",
                    "mask": null,
                    "value": 2054
                  }
                }
              ],
              "type": 1
            }
          },
          "priority": 3,
          "reason": 0,
          "table_id": 0
        }
      },
      {
        "OFPPFlowUpdateAbbrev": {
          "event": 4,
          "length": 8,
          "xid": 1234
        }
      },
      {
        "OFPPFlowUpdatePaused": {
          "event": 5,

```

```

        "length": 8
    }
}
],
"flags": 0,
"type": 16
}
}

```

class ryu.ofproto.ofproto_v1_5_parser.OFPBundleFeaturesStatsRequest (datapath, flags=0, feature_request_flags=0, properties=None, type_=None)

Bundle features request message

The controller uses this message to query a switch about its bundle capabilities, including whether it supports atomic bundles, ordered bundles, and scheduled bundles.

Attribute	Description
flags	Zero or OFPMPF_REQ_MORE
feature_request_flags	Bitmap of the following flags. OFPBF_TIMESTAMP OFPBF_TIME_SET_SCHED
properties	List of OFPBundleFeaturesProp subclass instance

Example:

```

def send_bundle_features_stats_request(self, datapath):
    ofp = datapath.ofproto
    ofp_parser = datapath.ofproto_parser

    req = ofp_parser.OFPBundleFeaturesStatsRequest(datapath, 0)
    datapath.send_msg(req)

```

JSON Example:

```

{
  "OFPBundleFeaturesStatsRequest": {
    "feature_request_flags": 3,
    "flags": 0,
    "properties": [
      {
        "OFPBundleFeaturesPropTime": {
          "length": 72,
          "sched_accuracy": {
            "OFPTime": {
              "nanoseconds": 1717986918,
              "seconds": 6148914691236517205
            }
          },
          "sched_max_future": {
            "OFPTime": {

```

```

        "nanoseconds": 2290649224,
        "seconds": 8608480567731124087
    },
    "sched_max_past": {
        "OFPTime": {
            "nanoseconds": 2863311530,
            "seconds": 11068046444225730969
        }
    },
    "timestamp": {
        "OFPTime": {
            "nanoseconds": 3435973836,
            "seconds": 13527612320720337851
        }
    },
    "type": 1
},
]
"properties": 19
}
}
}

```

`class ryu.ofproto.ofproto_v1_5_parser.OFPBundleFeaturesStatsReply` (*datapath*, *type_=None*, ***kwargs*)

Bundle features reply message

The switch responds with this message to a bundle features request.

Attribute	Description
body	Instance of OFPBundleFeaturesStats

Example:

```

@set_ev_cls(ofp_event.EventOFPBundleFeaturesStatsReply, MAIN_DISPATCHER)
def bundle_features_stats_reply_handler(self, ev):
    body = ev.msg.body

    self.logger.debug('OFPBundleFeaturesStats: capabilities=%0x%08x '
                      'properties=%s',
                      body.capabilities, repr(body.properties))

```

JSON Example:

```

{
  "OFPBundleFeaturesStatsReply": {
    "body": {
      "OFPBundleFeaturesStats": {
        "capabilities": 7,
        "properties": [
          {
            "OFPBundleFeaturesPropTime": {
              "length": 72,
              "sched_accuracy": {
                "OFPTime": {
                  "nanoseconds": 1717986918,
                  "seconds": 6148914691236517205
                }
              }
            }
          ]
        }
      }
    }
  }
}

```

```

    },
    "sched_max_future": {
      "OFPTIME": {
        "nanoseconds": 2290649224,
        "seconds": 8608480567731124087
      }
    },
    "sched_max_past": {
      "OFPTIME": {
        "nanoseconds": 2863311530,
        "seconds": 11068046444225730969
      }
    },
    "timestamp": {
      "OFPTIME": {
        "nanoseconds": 3435973836,
        "seconds": 13527612320720337851
      }
    },
    "type": 1
  }
}
]
}
},
"flags": 0,
"type": 19
}
}

```

class ryu.ofproto.ofproto_v1_5_parser.**OFPExperimentStatsRequest** (*datapath, flags, experimenter, exp_type, data, type_=None*)

Experimenter multipart request message

Attribute	Description
flags	Zero or OFPMPF_REQ_MORE
experimenter	Experimenter ID
exp_type	Experimenter defined
data	Experimenter defined additional data

JSON Example:

```

{
  "OFPExperimentStatsRequest": {
    "data": "aG9nZWlvZ2U=",
    "exp_type": 3405678728,
    "experimenter": 3735928495,
    "flags": 0,
    "type": 65535
  }
}

```

class ryu.ofproto.ofproto_v1_5_parser.**OFPExperimentStatsReply** (*datapath, type_=None, **kwargs*)

Experimenter multipart reply message

Attribute	Description
body	An OFPExperimenterMultipart instance

JSON Example:

```
{
  "OFPExperimenterStatsReply": {
    "body": {
      "OFPExperimenterMultipart": {
        "data": "dGVzdGRhdGE5OTk5OTk5OQ==",
        "exp_type": 3405674359,
        "experimenter": 3735928495
      }
    },
    "flags": 0,
    "type": 65535
  }
}
```

Packet-Out Message

class ryu.ofproto.ofproto_v1_5_parser.OFPPacketOut (datapath, *buffer_id=None*, *match=None*, *actions=None*, *data=None*, *actions_len=None*)

Packet-Out message

The controller uses this message to send a packet out through the switch.

Attribute	Description
buffer_id	ID assigned by datapath (OFP_NO_BUFFER if none)
match	Instance of OFPMatch (in_port is mandatory in the match field)
actions	list of OpenFlow action class
data	Packet data

Example:

```
def send_packet_out(self, datapath, buffer_id, in_port):
    ofp = datapath.ofproto
    ofp_parser = datapath.ofproto_parser

    match = OFPMatch(in_port=in_port)
    actions = [ofp_parser.OFPActionOutput(ofp.OFPP_FLOOD, 0)]
    req = ofp_parser.OFPPacketOut(datapath, buffer_id,
                                  match, actions)

    datapath.send_msg(req)
```

JSON Example:

```
{
  "OFPPacketOut": {
    "actions": [
      {
        "OFPActionOutput": {
          "len": 16,
          "max_len": 65535,
          "port": 4294967291,
          "type": 0
        }
      }
    ]
  }
}
```



```

    ],
    "actions_len": 16,
    "buffer_id": 4294967295,
    "data": "dGVzdA==",
    "match": {
        "OFPMatch": {
            "length": 12,
            "oxm_fields": [
                {
                    "OXMTlv": {
                        "field": "in_port",
                        "mask": null,
                        "value": 4294967040
                    }
                }
            ],
            "type": 1
        }
    }
}

```

Barrier Message

class `ryu.ofproto.ofproto_v1_5_parser.OFPBarrierRequest` (*datapath*)

Barrier request message

The controller sends this message to ensure message dependencies have been met or receive notifications for completed operations.

Example:

```

def send_barrier_request(self, datapath):
    ofp_parser = datapath.ofproto_parser

    req = ofp_parser.OFPBarrierRequest(datapath)
    datapath.send_msg(req)

```

JSON Example:

```

{
  "OFPBarrierRequest": {}
}

```

class `ryu.ofproto.ofproto_v1_5_parser.OFPBarrierReply` (*datapath*)

Barrier reply message

The switch responds with this message to a barrier request.

Example:

```

@set_ev_cls(ofp_event.EventOFPBarrierReply, MAIN_DISPATCHER)
def barrier_reply_handler(self, ev):
    self.logger.debug('OFPBarrierReply received')

```

JSON Example:

```
{
  "OFPPBarrierReply": {}
}
```

Role Request Message

class ryu.ofproto.ofproto_v1_5_parser.**OFPPRoleRequest** (*datapath*, *short_id=None*, *generation_id=None*, *role=None*)

Role request message

The controller uses this message to change its role.

Attribute	Description
role	One of the following values. OFPCR_ROLE_NOCHANGE OFPCR_ROLE_EQUAL OFPCR_ROLE_MASTER OFPCR_ROLE_SLAVE
short_id	ID number for the controller. The default is OFPCID_UNDEFINED.
generation_id	Master Election Generation ID

Example:

```
def send_role_request(self, datapath):
    ofp = datapath.ofproto
    ofp_parser = datapath.ofproto_parser

    req = ofp_parser.OFPPRoleRequest(datapath, ofp.OFPCR_ROLE_EQUAL,
                                     ofp.OFPCID_UNDEFINED, 0)

    datapath.send_msg(req)
```

JSON Example:

```
{
  "OFPPRoleRequest": {
    "generation_id": 1234605616436508552,
    "role": 1,
    "short_id": 43690
  }
}
```

class ryu.ofproto.ofproto_v1_5_parser.**OFPPRoleReply** (*datapath*, *role=None*, *short_id=None*, *generation_id=None*)

Role reply message

The switch responds with this message to a role request.

Attribute	Description
role	One of the following values. OFPCR_ROLE_NOCHANGE OFPCR_ROLE_EQUAL OFPCR_ROLE_MASTER OFPCR_ROLE_SLAVE
short_id	ID number for the controller. The default is OFP-CID_UNDEFINED.
generation_id	Master Election Generation ID

Example:

```
@set_ev_cls(ofp_event.EventOFPCRReply, MAIN_DISPATCHER)
def role_reply_handler(self, ev):
    msg = ev.msg
    dp = msg.datapath
    ofp = dp.ofproto

    if msg.role == ofp.OFPCR_ROLE_NOCHANGE:
        role = 'NOCHANGE'
    elif msg.role == ofp.OFPCR_ROLE_EQUAL:
        role = 'EQUAL'
    elif msg.role == ofp.OFPCR_ROLE_MASTER:
        role = 'MASTER'
    elif msg.role == ofp.OFPCR_ROLE_SLAVE:
        role = 'SLAVE'
    else:
        role = 'unknown'

    self.logger.debug('OFPCRReply received: '
                      'role=%s short_id=%d, generation_id=%d',
                      role, msg.short_id, msg.generation_id)
```

JSON Example:

```
{
  "OFPCRReply": {
    "generation_id": 1234605616436508552,
    "role": 1,
    "short_id": 43690
  }
}
```

Bundle Messages

```
class ryu.ofproto.ofproto_v1_5_parser.OFPBundleCtrlMsg(datapath, bundle_id=None,
                                                         type_=None, flags=None,
                                                         properties=None)
```

Bundle control message

The controller uses this message to create, destroy and commit bundles

Attribute	Description
bundle_id	Id of the bundle
type	One of the following values. OFPBCT_OPEN_REQUEST OFPBCT_OPEN_REPLY OFPBCT_CLOSE_REQUEST OFPBCT_CLOSE_REPLY OFPBCT_COMMIT_REQUEST OFPBCT_COMMIT_REPLY OFPBCT_DISCARD_REQUEST OFPBCT_DISCARD_REPLY
flags	Bitmap of the following flags. OFPBF_ATOMIC OFPBF_ORDERED
properties	List of OFPBundleProp subclass instance

Example:

```
def send_bundle_control(self, datapath):
    ofp = datapath.ofproto
    ofp_parser = datapath.ofproto_parser

    req = ofp_parser.OFPBundleCtrlMsg(datapath, 7,
                                       ofp.OFPBCT_OPEN_REQUEST,
                                       [ofp.OFPBF_ATOMIC], [])

    datapath.send_msg(req)
```

JSON Example:

```
{
  "OFPBundleCtrlMsg": {
    "bundle_id": 99999999,
    "flags": 1,
    "properties": [],
    "type": 1
  }
}
```

class ryu.ofproto.ofproto_v1_5_parser.**OFPBundleAddMsg**(datapath, bundle_id, flags, message, properties)

Bundle control message

The controller uses this message to create, destroy and commit bundles

Attribute	Description
bundle_id	Id of the bundle
flags	Bitmap of the following flags. OFPBF_ATOMIC OFPBF_ORDERED
message	MsgBase subclass instance
properties	List of OFPBundleProp subclass instance

Example:

```
def send_bundle_add_message(self, datapath):
    ofp = datapath.ofproto
    ofp_parser = datapath.ofproto_parser

    msg = ofp_parser.OFPRoleRequest(datapath, ofp.OFPCR_ROLE_EQUAL, 0)

    req = ofp_parser.OFPBundleAddMsg(datapath, 7, [ofp.OFPBF_ATOMIC],
                                     msg, [])

    datapath.send_msg(req)
```

JSON Example:

```
{
  "OFPBundleAddMsg": {
    "bundle_id": 999999999,
    "flags": 1,
    "message": {
      "OFPPFlowMod": {
        "buffer_id": 0,
        "command": 0,
        "cookie": 1311768467463790320,
        "cookie_mask": 18446744073709551615,
        "flags": 0,
        "hard_timeout": 0,
        "idle_timeout": 0,
        "importance": 39032,
        "instructions": [
          {
            "OFPInstructionActions": {
              "actions": [
                {
                  "OFPActionPopVlan": {
                    "len": 8,
                    "type": 18
                  }
                },
                {
                  "OFPActionSetField": {
                    "field": {
                      "OXMTlv": {
                        "field": "ipv4_dst",
                        "mask": null,
                        "value": "192.168.2.9"
                      }
                    },
                    "len": 16,
                    "type": 25
                  }
                }
              ]
            },
            {
              "NXActionLearn": {
                "cookie": 0,
                "experimenter": 8992,
                "fin_hard_timeout": 0,
                "fin_idle_timeout": 0,
                "flags": 0,
                "hard_timeout": 300,

```

```
"idle_timeout": 0,
"len": 96,
"priority": 1,
"specs": [
  {
    "NXFlowSpecMatch": {
      "dst": [
        "vlan_vid",
        0
      ],
      "n_bits": 12,
      "src": [
        "vlan_vid",
        0
      ]
    }
  },
  {
    "NXFlowSpecMatch": {
      "dst": [
        "eth_dst_nxm",
        0
      ],
      "n_bits": 48,
      "src": [
        "eth_src_nxm",
        0
      ]
    }
  },
  {
    "NXFlowSpecLoad": {
      "dst": [
        "vlan_vid",
        0
      ],
      "n_bits": 12,
      "src": 0
    }
  },
  {
    "NXFlowSpecLoad": {
      "dst": [
        "tunnel_id_nxm",
        0
      ],
      "n_bits": 64,
      "src": [
        "tunnel_id_nxm",
        0
      ]
    }
  },
  {
    "NXFlowSpecOutput": {
      "dst": "",
      "n_bits": 32,
      "src": [
```

```

        "in_port",
        0
    ]
    }
    ],
    "subtype": 16,
    "table_id": 99,
    "type": 65535
}
],
"len": 128,
"type": 4
},
{
    "OFPInstructionGotoTable": {
        "len": 8,
        "table_id": 100,
        "type": 1
    }
},
],
"match": {
    "OFPMatch": {
        "length": 70,
        "oxm_fields": [
            {
                "OXMTlv": {
                    "field": "in_port",
                    "mask": null,
                    "value": 43981
                }
            },
            {
                "OXMTlv": {
                    "field": "eth_dst",
                    "mask": null,
                    "value": "aa:bb:cc:99:88:77"
                }
            },
            {
                "OXMTlv": {
                    "field": "eth_type",
                    "mask": null,
                    "value": 2048
                }
            },
            {
                "OXMTlv": {
                    "field": "vlan_vid",
                    "mask": null,
                    "value": 5095
                }
            }
        ]
    }
}

```

```

        "field": "ipv4_dst",
        "mask": null,
        "value": "192.168.2.1"
    }
},
{
    "OXMTlv": {
        "field": "tunnel_id",
        "mask": null,
        "value": 50000
    }
},
{
    "OXMTlv": {
        "field": "tun_ipv4_src",
        "mask": null,
        "value": "192.168.2.3"
    }
},
{
    "OXMTlv": {
        "field": "tun_ipv4_dst",
        "mask": null,
        "value": "192.168.2.4"
    }
}
],
"type": 1
}
},
"out_group": 0,
"out_port": 0,
"priority": 0,
"table_id": 2
}
},
"properties": []
}
}

```

Set Asynchronous Configuration Message

class ryu.ofproto.ofproto_v1_5_parser.**OFPSetAsync** (*datapath*, *properties=None*)

Set asynchronous configuration message

The controller sends this message to set the asynchronous messages that it wants to receive on a given OpenFlow channel.

Attribute	Description
properties	List of OFPAsyncConfigProp subclass instances

Example:

```

def send_set_async(self, datapath):
    ofp = datapath.ofproto
    ofp_parser = datapath.ofproto_parser

    properties = [ofp_parser.OFPAsyncConfigPropReasons(

```



```

        8, ofp_parser.OFPACPT_PACKET_IN_SLAVE,
        (ofp_parser.OFPR_APPLY_ACTION |
         ofp_parser.OFPR_INVALID_TTL)),
        ofp_parser.OFPAsyncConfigPropExperimenter(
        ofp.OFPTFPT_EXPERIMENTER_MASTER,
        16, 100, 2, bytearray())]
req = ofp_parser.OFPSetAsync(datapath, properties)
datapath.send_msg(req)

```

JSON Example:

```

{
  "OFPSetAsync": {
    "properties": [
      {
        "OFPAsyncConfigPropReasons": {
          "length": 8,
          "mask": 3,
          "type": 0
        }
      },
      {
        "OFPAsyncConfigPropReasons": {
          "length": 8,
          "mask": 3,
          "type": 1
        }
      },
      {
        "OFPAsyncConfigPropReasons": {
          "length": 8,
          "mask": 3,
          "type": 2
        }
      },
      {
        "OFPAsyncConfigPropReasons": {
          "length": 8,
          "mask": 3,
          "type": 3
        }
      },
      {
        "OFPAsyncConfigPropReasons": {
          "length": 8,
          "mask": 3,
          "type": 4
        }
      },
      {
        "OFPAsyncConfigPropReasons": {
          "length": 8,
          "mask": 3,
          "type": 5
        }
      },
      {
        "OFPAsyncConfigPropReasons": {

```

```
        "length": 8,
        "mask": 3,
        "type": 6
    },
    {
        "OFPAsyncConfigPropReasons": {
            "length": 8,
            "mask": 3,
            "type": 7
        }
    },
    {
        "OFPAsyncConfigPropReasons": {
            "length": 8,
            "mask": 24,
            "type": 8
        }
    },
    {
        "OFPAsyncConfigPropReasons": {
            "length": 8,
            "mask": 24,
            "type": 9
        }
    },
    {
        "OFPAsyncConfigPropReasons": {
            "length": 8,
            "mask": 3,
            "type": 10
        }
    },
    {
        "OFPAsyncConfigPropReasons": {
            "length": 8,
            "mask": 3,
            "type": 11
        }
    },
    {
        "OFPAsyncConfigPropExperimenter": {
            "data": [],
            "exp_type": 0,
            "experimenter": 101,
            "length": 12,
            "type": 65534
        }
    },
    {
        "OFPAsyncConfigPropExperimenter": {
            "data": [
                1
            ],
            "exp_type": 1,
            "experimenter": 101,
            "length": 16,
            "type": 65535
        }
    }
}
```

```

    },
    {
      "OFPPAsyncConfigPropExperimenter": {
        "data": [
          1,
          2
        ],
        "exp_type": 2,
        "experimenter": 101,
        "length": 20,
        "type": 65535
      }
    }
  ]
}

```

class ryu.ofproto.ofproto_v1_5_parser.**OFPPGetAsyncRequest** (*datapath*)
Get asynchronous configuration request message

The controller uses this message to query the asynchronous message.

Example:

```

def send_get_async_request(self, datapath):
    ofp_parser = datapath.ofproto_parser

    req = ofp_parser.OFPPGetAsyncRequest(datapath)
    datapath.send_msg(req)

```

JSON Example:

```

{
  "OFPPGetAsyncRequest": {}
}

```

class ryu.ofproto.ofproto_v1_5_parser.**OFPPGetAsyncReply** (*datapath*, *properties=None*)
Get asynchronous configuration reply message

The switch responds with this message to a get asynchronous configuration request.

Attribute	Description
properties	List of OFPPAsyncConfigProp subclass instances

Example:

```

@set_ev_cls(ofp_event.EventOFPPGetAsyncReply, MAIN_DISPATCHER)
def get_async_reply_handler(self, ev):
    msg = ev.msg

    self.logger.debug('OFPPGetAsyncReply received: '
                      'properties=%s', repr(msg.properties))

```

JSON Example:

```

{
  "OFPPGetAsyncReply": {
    "properties": [
      {
        "OFPPAsyncConfigPropReasons": {

```

```
        "length": 8,  
        "mask": 3,  
        "type": 0  
    },  
    {  
        "OFPAsyncConfigPropReasons": {  
            "length": 8,  
            "mask": 3,  
            "type": 1  
        }  
    },  
    {  
        "OFPAsyncConfigPropReasons": {  
            "length": 8,  
            "mask": 3,  
            "type": 2  
        }  
    },  
    {  
        "OFPAsyncConfigPropReasons": {  
            "length": 8,  
            "mask": 3,  
            "type": 3  
        }  
    },  
    {  
        "OFPAsyncConfigPropReasons": {  
            "length": 8,  
            "mask": 3,  
            "type": 4  
        }  
    },  
    {  
        "OFPAsyncConfigPropReasons": {  
            "length": 8,  
            "mask": 3,  
            "type": 5  
        }  
    },  
    {  
        "OFPAsyncConfigPropReasons": {  
            "length": 8,  
            "mask": 3,  
            "type": 6  
        }  
    },  
    {  
        "OFPAsyncConfigPropReasons": {  
            "length": 8,  
            "mask": 3,  
            "type": 7  
        }  
    },  
    {  
        "OFPAsyncConfigPropReasons": {  
            "length": 8,  
            "mask": 24,  
            "type": 8  
        }  
    }  
}
```

```

        "type": 8
    },
    {
        "OFPAsyncConfigPropReasons": {
            "length": 8,
            "mask": 24,
            "type": 9
        }
    },
    {
        "OFPAsyncConfigPropReasons": {
            "length": 8,
            "mask": 3,
            "type": 10
        }
    },
    {
        "OFPAsyncConfigPropReasons": {
            "length": 8,
            "mask": 3,
            "type": 11
        }
    },
    {
        "OFPAsyncConfigPropExperimenter": {
            "data": [],
            "exp_type": 0,
            "experimenter": 101,
            "length": 12,
            "type": 65534
        }
    },
    {
        "OFPAsyncConfigPropExperimenter": {
            "data": [
                1
            ],
            "exp_type": 1,
            "experimenter": 101,
            "length": 16,
            "type": 65535
        }
    },
    {
        "OFPAsyncConfigPropExperimenter": {
            "data": [
                1,
                2
            ],
            "exp_type": 2,
            "experimenter": 101,
            "length": 20,
            "type": 65535
        }
    }
]
}

```

```
}

```

Asynchronous Messages

Packet-In Message

```
class ryu.ofproto.ofproto_v1_5_parser.OFPPacketIn(datapath, buffer_id=None, total_len=None, reason=None, table_id=None, cookie=None, match=None, data=None)
```

Packet-In message

The switch sends the packet that received to the controller by this message.

Attribute	Description
buffer_id	ID assigned by datapath
total_len	Full length of frame
reason	Reason packet is being sent. OFPR_TABLE_MISS OFPR_APPLY_ACTION OFPR_INVALID_TTL OFPR_ACTION_SET OFPR_GROUP OFPR_PACKET_OUT
table_id	ID of the table that was looked up
cookie	Cookie of the flow entry that was looked up
match	Instance of OFPMatch
data	Ethernet frame

Example:

```
@set_ev_cls(ofp_event.EventOFPPacketIn, MAIN_DISPATCHER)
def packet_in_handler(self, ev):
    msg = ev.msg
    dp = msg.datapath
    ofp = dp.ofproto

    if msg.reason == ofp.TABLE_MISS:
        reason = 'TABLE MISS'
    elif msg.reason == ofp.OFPR_APPLY_ACTION:
        reason = 'APPLY ACTION'
    elif msg.reason == ofp.OFPR_INVALID_TTL:
        reason = 'INVALID TTL'
    elif msg.reason == ofp.OFPR_ACTION_SET:
        reason = 'ACTION SET'
    elif msg.reason == ofp.OFPR_GROUP:
        reason = 'GROUP'
    elif msg.reason == ofp.OFPR_PACKET_OUT:
        reason = 'PACKET OUT'
    else:
        reason = 'unknown'

    self.logger.debug('OFPPacketIn received: '
```

```
'buffer_id=%x total_len=%d reason=%s '
'table_id=%d cookie=%d match=%s data=%s',
msg.buffer_id, msg.total_len, reason,
msg.table_id, msg.cookie, msg.match,
utils.hex_array(msg.data))
```

JSON Example:

```
{
  "OFPPacketIn": {
    "buffer_id": 200,
    "cookie": 0,
    "data": "aG9nZQ==",
    "match": {
      "OFPMatch": {
        "length": 40,
        "oxm_fields": [
          {
            "OXMTlv": {
              "field": "in_port",
              "mask": null,
              "value": 43981
            }
          },
          {
            "OXMTlv": {
              "field": "tunnel_id",
              "mask": null,
              "value": 50000
            }
          },
          {
            "OXMTlv": {
              "field": "tun_ipv4_src",
              "mask": null,
              "value": "192.168.2.3"
            }
          },
          {
            "OXMTlv": {
              "field": "tun_ipv4_dst",
              "mask": null,
              "value": "192.168.2.4"
            }
          }
        ],
        "type": 1
      }
    },
    "reason": 0,
    "table_id": 100,
    "total_len": 1000
  }
}
```

Flow Removed Message

```
class ryu.ofproto.ofproto_v1_5_parser.OFPFlowRemoved (datapath,          table_id=None,
                                                    reason=None,          prior-
                                                    ity=None,          idle_timeout=None,
                                                    hard_timeout=None,
                                                    cookie=None,          match=None,
                                                    stats=None)
```

Flow removed message

When flow entries time out or are deleted, the switch notifies controller with this message.

Attribute	Description
table_id	ID of the table
reason	One of the following values. OFPRR_IDLE_TIMEOUT OFPRR_HARD_TIMEOUT OFPRR_DELETE OFPRR_GROUP_DELETE OFPRR_METER_DELETE OFPRR_EVICTION
priority	Priority level of flow entry
idle_timeout	Idle timeout from original flow mod
hard_timeout	Hard timeout from original flow mod
cookie	Opaque controller-issued identifier
match	Instance of OFPMatch
stats	Instance of OFPStats

Example:

```
@set_ev_cls(ofp_event.EventOFPFlowRemoved, MAIN_DISPATCHER)
def flow_removed_handler(self, ev):
    msg = ev.msg
    dp = msg.datapath
    ofp = dp.ofproto

    if msg.reason == ofp.OFPRR_IDLE_TIMEOUT:
        reason = 'IDLE TIMEOUT'
    elif msg.reason == ofp.OFPRR_HARD_TIMEOUT:
        reason = 'HARD TIMEOUT'
    elif msg.reason == ofp.OFPRR_DELETE:
        reason = 'DELETE'
    elif msg.reason == ofp.OFPRR_GROUP_DELETE:
        reason = 'GROUP DELETE'
    elif msg.reason == ofp.OFPRR_METER_DELETE:
        reason = 'METER DELETE'
    elif msg.reason == ofp.OFPRR_EVICTION:
        reason = 'EVICTION'
    else:
        reason = 'unknown'

    self.logger.debug('OFPFlowRemoved received: '
                      'table_id=%d reason=%s priority=%d '
                      'idle_timeout=%d hard_timeout=%d cookie=%d '
                      'match=%s stats=%s',
```



```
msg.table_id, reason, msg.priority,
msg.idle_timeout, msg.hard_timeout, msg.cookie,
msg.match, msg.stats)
```

JSON Example:

```
{
  "OFPPortRemoved": {
    "cookie": 1234605616436508552,
    "hard_timeout": 255,
    "idle_timeout": 255,
    "match": {
      "OFPMatch": {
        "length": 12,
        "oxm_fields": [
          {
            "OXMTlv": {
              "field": "in_port",
              "mask": null,
              "value": 1
            }
          }
        ],
        "type": 1
      }
    },
    "priority": 1,
    "reason": 0,
    "stats": {
      "OFPPStats": {
        "length": 12,
        "oxs_fields": [
          {
            "OXSTlv": {
              "field": "flow_count",
              "value": 1
            }
          }
        ]
      }
    },
    "table_id": 1
  }
}
```

Port Status Message

class ryu.ofproto.ofproto_v1_5_parser.**OFPPortStatus** (*datapath*, *reason=None*,
desc=None)

Port status message

The switch notifies controller of change of ports.

Attribute	Description
reason	One of the following values. OFPPR_ADD OFPPR_DELETE OFPPR_MODIFY
desc	instance of OFPPort

Example:

```
@set_ev_cls(ofp_event.EventOFPPortStatus, MAIN_DISPATCHER)
def port_status_handler(self, ev):
    msg = ev.msg
    dp = msg.datapath
    ofp = dp.ofproto

    if msg.reason == ofp.OFPPR_ADD:
        reason = 'ADD'
    elif msg.reason == ofp.OFPPR_DELETE:
        reason = 'DELETE'
    elif msg.reason == ofp.OFPPR_MODIFY:
        reason = 'MODIFY'
    else:
        reason = 'unknown'

    self.logger.debug('OFPPortStatus received: reason=%s desc=%s',
                      reason, msg.desc)
```

JSON Example:

```
{
  "OFPPortStatus": {
    "desc": {
      "OFPPort": {
        "config": 0,
        "hw_addr": "f2:0b:a4:d0:3f:70",
        "length": 168,
        "name": "\u79c1\u306e\u30dd\u30fc\u30c8",
        "port_no": 7,
        "properties": [
          {
            "OFPPortDescPropEthernet": {
              "advertised": 10240,
              "curr": 10248,
              "curr_speed": 5000,
              "length": 32,
              "max_speed": 5000,
              "peer": 10248,
              "supported": 10248,
              "type": 0
            }
          },
          {
            "OFPPortDescPropOptical": {
              "length": 40,
              "rx_grid_freq_lmda": 1500,
              "rx_max_freq_lmda": 2000,
              "rx_min_freq_lmda": 1000,
            }
          }
        ]
      }
    }
  }
}
```

```

        "supported": 1,
        "tx_grid_freq_lmda": 1500,
        "tx_max_freq_lmda": 2000,
        "tx_min_freq_lmda": 1000,
        "tx_pwr_max": 2000,
        "tx_pwr_min": 1000,
        "type": 1
    },
    {
        "OFPPortDescPropExperimenter": {
            "data": [],
            "exp_type": 0,
            "experimenter": 101,
            "length": 12,
            "type": 65535
        }
    },
    {
        "OFPPortDescPropExperimenter": {
            "data": [
                1
            ],
            "exp_type": 1,
            "experimenter": 101,
            "length": 16,
            "type": 65535
        }
    },
    {
        "OFPPortDescPropExperimenter": {
            "data": [
                1,
                2
            ],
            "exp_type": 2,
            "experimenter": 101,
            "length": 20,
            "type": 65535
        }
    }
],
"state": 4
},
"reason": 0
}
}

```

Controller Role Status Message

class ryu.ofproto.ofproto_v1_5_parser.OFPRoleStatus (datapath, role=None, reason=None, generation_id=None, properties=None)

Role status message

The switch notifies controller of change of role.

Attribute	Description
role	One of the following values. OFPCR_ROLE_NOCHANGE OFPCR_ROLE_EQUAL OFPCR_ROLE_MASTER
reason	One of the following values. OFPCRR_MASTER_REQUEST OFPCRR_CONFIG OFPCRR_EXPERIMENTER
generation_id	Master Election Generation ID
properties	List of OFPRoleProp subclass instance

Example:

```
@set_ev_cls(ofp_event.EventOFPSRoleStatus, MAIN_DISPATCHER)
def role_status_handler(self, ev):
    msg = ev.msg
    dp = msg.datapath
    ofp = dp.ofproto

    if msg.role == ofp.OFPCR_ROLE_NOCHANGE:
        role = 'ROLE NOCHANGE'
    elif msg.role == ofp.OFPCR_ROLE_EQUAL:
        role = 'ROLE EQUAL'
    elif msg.role == ofp.OFPCR_ROLE_MASTER:
        role = 'ROLE MASTER'
    else:
        role = 'unknown'

    if msg.reason == ofp.OFPCRR_MASTER_REQUEST:
        reason = 'MASTER REQUEST'
    elif msg.reason == ofp.OFPCRR_CONFIG:
        reason = 'CONFIG'
    elif msg.reason == ofp.OFPCRR_EXPERIMENTER:
        reason = 'EXPERIMENTER'
    else:
        reason = 'unknown'

    self.logger.debug('OFPSRoleStatus received: role=%s reason=%s '
                      'generation_id=%d properties=%s', role, reason,
                      msg.generation_id, repr(msg.properties))
```

JSON Example:

```
{
  "OFPSRoleStatus": {
    "generation_id": 17356517385562371090,
    "properties": [],
    "reason": 0,
    "role": 3
  }
}
```

Table Status Message

class ryu.ofproto.ofproto_v1_5_parser.**OFPTTableStatus** (*datapath*, *reason=None*, *table=None*)

Table status message

The switch notifies controller of change of table status.

Attribute	Description
reason	One of the following values. OFPTR_VACANCY_DOWN OFPTR_VACANCY_UP
table	OFPTTableDesc instance

Example:

```
@set_ev_cls(ofp_event.EventOFPTTableStatus, MAIN_DISPATCHER)
def table(self, ev):
    msg = ev.msg
    dp = msg.datapath
    ofp = dp.ofproto

    if msg.reason == ofp.OFPTR_VACANCY_DOWN:
        reason = 'VACANCY_DOWN'
    elif msg.reason == ofp.OFPTR_VACANCY_UP:
        reason = 'VACANCY_UP'
    else:
        reason = 'unknown'

    self.logger.debug('OFPTTableStatus received: reason=%s '
                      'table_id=%d config=0x%08x properties=%s',
                      reason, msg.table.table_id, msg.table.config,
                      repr(msg.table.properties))
```

JSON Example:

```
{
  "OFPTTableStatus": {
    "reason": 3,
    "table": {
      "OFPTTableDesc": {
        "config": 0,
        "length": 80,
        "properties": [
          {
            "OFPTTableModPropEviction": {
              "flags": 0,
              "length": 8,
              "type": 2
            }
          },
          {
            "OFPTTableModPropVacancy": {
              "length": 8,
              "type": 3,
              "vacancy": 0,
              "vacancy_down": 0,
            }
          }
        ]
      }
    }
  }
}
```

```
        "vacancy_up": 0
      }
    },
    {
      "OFPTableModPropExperimenter": {
        "data": [],
        "exp_type": 0,
        "experimenter": 101,
        "length": 12,
        "type": 65535
      }
    },
    {
      "OFPTableModPropExperimenter": {
        "data": [
          1
        ],
        "exp_type": 1,
        "experimenter": 101,
        "length": 16,
        "type": 65535
      }
    },
    {
      "OFPTableModPropExperimenter": {
        "data": [
          1,
          2
        ],
        "exp_type": 2,
        "experimenter": 101,
        "length": 20,
        "type": 65535
      }
    }
  ],
  "table_id": 8
}
}
}
```

Request Forward Message

class ryu.ofproto.ofproto_v1_5_parser.OFPRequestForward (datapath, request=None)

Forwarded request message

The switch forwards request messages from one controller to other controllers.

Attribute	Description
request	OFPGroupMod or OFPMeterMod instance

Example:

```
@set_ev_cls(ofp_event.EventOFPRequestForward, MAIN_DISPATCHER)
def request_forward_handler(self, ev):
    msg = ev.msg
    dp = msg.datapath
```

```

ofp = dp.ofproto

if msg.request.msg_type == ofp.OFPT_GROUP_MOD:
    self.logger.debug(
        'OFPPRequestForward received: request=OFPPGroupMod('
        'command=%d, type=%d, group_id=%d, command_bucket_id=%d, '
        'buckets=%s, properties=%s)',
        msg.request.command, msg.request.type,
        msg.request.group_id, msg.request.command_bucket_id,
        msg.request.buckets, repr(msg.request.properties))
elif msg.request.msg_type == ofp.OFPT_METER_MOD:
    self.logger.debug(
        'OFPPRequestForward received: request=OFPPMeterMod('
        'command=%d, flags=%d, meter_id=%d, bands=%s)',
        msg.request.command, msg.request.flags,
        msg.request.meter_id, msg.request.bands)
else:
    self.logger.debug(
        'OFPPRequestForward received: request=Unknown')

```

JSON Example:

```

{
  "OFPPRequestForward": {
    "request": {
      "OFPPGroupMod": {
        "bucket_array_len": 56,
        "buckets": [
          {
            "OFPPBucket": {
              "action_array_len": 24,
              "actions": [
                {
                  "OFPPActionPopVlan": {
                    "len": 8,
                    "type": 18
                  }
                },
                {
                  "OFPPActionSetField": {
                    "field": {
                      "OXMTlv": {
                        "field": "ipv4_dst",
                        "mask": null,
                        "value": "192.168.2.9"
                      }
                    }
                  },
                  "len": 16,
                  "type": 25
                }
              ]
            },
            "bucket_id": 305419896,
            "len": 56,
            "properties": [
              {
                "OFPPGroupBucketPropWeight": {
                  "length": 8,

```



```

        role = 'SLAVE'
    else:
        role = 'unknown'

    if status.reason == ofp.OFPCSR_REQUEST:
        reason = 'REQUEST'
    elif status.reason == ofp.OFPCSR_CHANNEL_STATUS:
        reason = 'CHANNEL_STATUS'
    elif status.reason == ofp.OFPCSR_ROLE:
        reason = 'ROLE'
    elif status.reason == ofp.OFPCSR_CONTROLLER_ADDED:
        reason = 'CONTROLLER_ADDED'
    elif status.reason == ofp.OFPCSR_CONTROLLER_REMOVED:
        reason = 'CONTROLLER_REMOVED'
    elif status.reason == ofp.OFPCSR_SHORT_ID:
        reason = 'SHORT_ID'
    elif status.reason == ofp.OFPCSR_EXPERIMENTER:
        reason = 'EXPERIMENTER'
    else:
        reason = 'unknown'

    if status.channel_status == OFPCT_STATUS_UP:
        channel_status = 'UP'
    if status.channel_status == OFPCT_STATUS_DOWN:
        channel_status = 'DOWN'
    else:
        channel_status = 'unknown'

    self.logger.debug('OFPControllerStatus received: short_id=%d'
                      'role=%s reason=%s channel_status=%s '
                      'properties=%s',
                      status.short_id, role, reason, channel_status,
                      repr(status.properties))

```

JSON Example:

```

{
  "OFPControllerStatus": {
    "status": {
      "OFPControllerStatusStats": {
        "channel_status": 1,
        "length": 48,
        "properties": [
          {
            "OFPControllerStatusPropUri": {
              "length": 26,
              "type": 0,
              "uri": "tls:192.168.34.23:6653"
            }
          }
        ],
        "reason": 1,
        "role": 1,
        "short_id": 65535
      }
    }
  }
}

```

Symmetric Messages

Hello

class ryu.ofproto.ofproto_v1_5_parser.**OFPHello** (*datapath*, *elements=None*)
Hello message

When connection is started, the hello message is exchanged between a switch and a controller.

This message is handled by the Ryu framework, so the Ryu application do not need to process this typically.

Attribute	Description
elements	list of OFPHelloElemVersionBitmap instance

JSON Example:

```
{
  "OFPHello": {
    "elements": [
      {
        "OFPHelloElemVersionBitmap": {
          "length": 8,
          "type": 1,
          "versions": [
            6
          ]
        }
      ]
    ]
  }
}
```

class ryu.ofproto.ofproto_v1_5_parser.**OFPHelloElemVersionBitmap** (*versions*,
type_=None,
length=None)

Version bitmap Hello Element

Attribute	Description
versions	list of versions of OpenFlow protocol a device supports

Echo Request

class ryu.ofproto.ofproto_v1_5_parser.**OFPEchoRequest** (*datapath*, *data=None*)
Echo request message

This message is handled by the Ryu framework, so the Ryu application do not need to process this typically.

Attribute	Description
data	An arbitrary length data

Example:

```
def send_echo_request(self, datapath, data):
    ofp_parser = datapath.ofproto_parser

    req = ofp_parser.OFPEchoRequest(datapath, data)
    datapath.send_msg(req)

    @set_ev_cls(ofp_event.EventOFPEchoRequest,
```

```
[HANDSHAKE_DISPATCHER, CONFIG_DISPATCHER, MAIN_DISPATCHER])
def echo_request_handler(self, ev):
    self.logger.debug('OFPEchoRequest received: data=%s',
                      utils.hex_array(ev.msg.data))
```

JSON Example:

```
{
  "OFPEchoRequest": {
    "data": ""
  }
}
```

Echo Reply

class ryu.ofproto.ofproto_v1_5_parser.**OFPEchoReply** (*datapath*, *data=None*)
Echo reply message

This message is handled by the Ryu framework, so the Ryu application do not need to process this typically.

Attribute	Description
data	An arbitrary length data

Example:

```
def send_echo_reply(self, datapath, data):
    ofp_parser = datapath.ofproto_parser

    reply = ofp_parser.OFPEchoReply(datapath, data)
    datapath.send_msg(reply)

@set_ev_cls(ofp_event.EventOFPEchoReply,
            [HANDSHAKE_DISPATCHER, CONFIG_DISPATCHER, MAIN_DISPATCHER])
def echo_reply_handler(self, ev):
    self.logger.debug('OFPEchoReply received: data=%s',
                      utils.hex_array(ev.msg.data))
```

JSON Example:

```
{
  "OFPEchoReply": {
    "data": ""
  }
}
```

Error Message

class ryu.ofproto.ofproto_v1_5_parser.**OFPErrormsg** (*datapath*, *type=None*, *code=None*,
data=None)
Error message

The switch notifies controller of problems by this message.

Attribute	Description
type	High level type of error
code	Details depending on the type
data	Variable length data depending on the type and code

type attribute corresponds to type_ parameter of __init__.

Types and codes are defined in ryu.ofproto.ofproto.

Type	Code
OFPET_HELLO_FAILED	OFPHFC_*
OFPET_BAD_REQUEST	OFPBRC_*
OFPET_BAD_ACTION	OFPBAC_*
OFPET_BAD_INSTRUCTION	OFPBIC_*
OFPET_BAD_MATCH	OFPBMC_*
OFPET_FLOW_MOD_FAILED	OFPFMFC_*
OFPET_GROUP_MOD_FAILED	OFPGMFC_*
OFPET_PORT_MOD_FAILED	OFPPMFC_*
OFPET_TABLE_MOD_FAILED	OFPTMFC_*
OFPET_QUEUE_OP_FAILED	OFPQOFC_*
OFPET_SWITCH_CONFIG_FAILED	OFPSCFC_*
OFPET_ROLE_REQUEST_FAILED	OFPRRFC_*
OFPET_METER_MOD_FAILED	OFPMMF_*
OFPET_TABLE_FEATURES_FAILED	OFPTFFC_*
OFPET_EXPERIMENTER	N/A

Example:

```
@set_ev_cls(ofp_event.EventOFPErrormsg,
            [HANDSHAKE_DISPATCHER, CONFIG_DISPATCHER, MAIN_DISPATCHER])
def error_msg_handler(self, ev):
    msg = ev.msg

    self.logger.debug('OFPErrormsg received: type=0x%02x code=0x%02x '
                      'message=%s',
                      msg.type, msg.code, utils.hex_array(msg.data))
```

JSON Example:

```
{
  "OFPErrormsg": {
    "code": 6,
    "data": "Bg4ACAAAAA=",
    "type": 4
  }
}
```

Experimenter

class ryu.ofproto.ofproto_v1_5_parser.OFPEXPERIMENTER (datapath, experimenter=None, exp_type=None, data=None)

Experimenter extension message

Attribute	Description
experimenter	Experimenter ID
exp_type	Experimenter defined
data	Experimenter defined arbitrary additional data

JSON Example:

```
{
  "OFPErrormsg": {
```

```

    "data": "amlra2VuIGRhdGE=",
    "exp_type": 60000,
    "experimenter": 999999,
    "type": 65535
  }
}

```

Port Structures

class ryu.ofproto.ofproto_v1_5_parser.**OFPPort** (*port_no=None, length=None, hw_addr=None, name=None, config=None, state=None, properties=None*)

Description of a port

Attribute	Description
port_no	Port number and it uniquely identifies a port within a switch.
length	Length of ofp_port (excluding padding).
hw_addr	MAC address for the port.
name	Null-terminated string containing a human-readable name for the interface.
config	Bitmap of port configuration flags. OFPPC_PORT_DOWN OFPPC_NO_RECV OFPPC_NO_FWD OFPPC_NO_PACKET_IN
state	Bitmap of port state flags. OFPPS_LINK_DOWN OFPPS_BLOCKED OFPPS_LIVE
properties	List of OFPPortDescProp subclass instance

Flow Match Structure

class ryu.ofproto.ofproto_v1_5_parser.**OFPMatch** (*type_=None, length=None, _ordered_fields=None, **kwargs*)

Flow Match Structure

This class is implementation of the flow match structure having compose/query API.

You can define the flow match by the keyword arguments. The following arguments are available.

Argument	Value	Description
in_port	Integer 32bit	Switch input port
in_phy_port	Integer 32bit	Switch physical input port
metadata	Integer 64bit	Metadata passed between tables
eth_dst	MAC address	Ethernet destination address
eth_src	MAC address	Ethernet source address
Continued on next page		

Table 2.4 – continued from previous page

Argument	Value	Description
eth_type	Integer 16bit	Ethernet frame type
vlan_vid	Integer 16bit	VLAN id
vlan_pcp	Integer 8bit	VLAN priority
ip_dscp	Integer 8bit	IP DSCP (6 bits in ToS field)
ip_ecn	Integer 8bit	IP ECN (2 bits in ToS field)
ip_proto	Integer 8bit	IP protocol
ipv4_src	IPv4 address	IPv4 source address
ipv4_dst	IPv4 address	IPv4 destination address
tcp_src	Integer 16bit	TCP source port
tcp_dst	Integer 16bit	TCP destination port
udp_src	Integer 16bit	UDP source port
udp_dst	Integer 16bit	UDP destination port
sctp_src	Integer 16bit	SCTP source port
sctp_dst	Integer 16bit	SCTP destination port
icmpv4_type	Integer 8bit	ICMP type
icmpv4_code	Integer 8bit	ICMP code
arp_op	Integer 16bit	ARP opcode
arp_spa	IPv4 address	ARP source IPv4 address
arp_tpa	IPv4 address	ARP target IPv4 address
arp_sha	MAC address	ARP source hardware address
arp_tha	MAC address	ARP target hardware address
ipv6_src	IPv6 address	IPv6 source address
ipv6_dst	IPv6 address	IPv6 destination address
ipv6_flabel	Integer 32bit	IPv6 Flow Label
icmpv6_type	Integer 8bit	ICMPv6 type
icmpv6_code	Integer 8bit	ICMPv6 code
ipv6_nd_target	IPv6 address	Target address for ND
ipv6_nd_sll	MAC address	Source link-layer for ND
ipv6_nd_tll	MAC address	Target link-layer for ND
mpls_label	Integer 32bit	MPLS label
mpls_tc	Integer 8bit	MPLS TC
mpls_bos	Integer 8bit	MPLS BoS bit
pbb_isid	Integer 24bit	PBB I-SID
tunnel_id	Integer 64bit	Logical Port Metadata
ipv6_exthdr	Integer 16bit	IPv6 Extension Header pseudo-field
pbb_uca	Integer 8bit	PBB UCA header field
tcp_flags	Integer 16bit	TCP flags
actset_output	Integer 32bit	Output port from action set metadata
packet_type	Integer 32bit	Packet type value

Example:

```
>>> # compose
>>> match = parser.OFPMatch(
...     in_port=1,
...     eth_type=0x86dd,
...     ipv6_src=('2001:db8:bd05:1d2:288a:1fc0:1:10ee',
...              'ffff:ffff:ffff:ffff::'),
...     ipv6_dst='2001:db8:bd05:1d2:288a:1fc0:1:10ee')
>>> # query
>>> if 'ipv6_src' in match:
```

```
...     print match['ipv6_src']
...
('2001:db8:bd05:1d2:288a:1fc0:1:10ee', 'ffff:ffff:ffff:ffff::')
```

Note: For the list of the supported Nicira experimenter matches, please refer to [ryu.ofproto.nx_match](#).

Note: For VLAN id match field, special values are defined in OpenFlow Spec.

1. Packets with and without a VLAN tag

•Example:

```
match = parser.OFPMatch()
```

•Packet Matching

non-VLAN-tagged	MATCH
VLAN-tagged(vlan_id=3)	MATCH
VLAN-tagged(vlan_id=5)	MATCH

2. Only packets without a VLAN tag

•Example:

```
match = parser.OFPMatch(vlan_vid=0x0000)
```

•Packet Matching

non-VLAN-tagged	MATCH
VLAN-tagged(vlan_id=3)	x
VLAN-tagged(vlan_id=5)	x

3. Only packets with a VLAN tag regardless of its value

•Example:

```
match = parser.OFPMatch(vlan_vid=(0x1000, 0x1000))
```

•Packet Matching

non-VLAN-tagged	x
VLAN-tagged(vlan_id=3)	MATCH
VLAN-tagged(vlan_id=5)	MATCH

4. Only packets with VLAN tag and VID equal

•Example:

```
match = parser.OFPMatch(vlan_vid=(0x1000 | 3))
```

•Packet Matching

non-VLAN-tagged	x
VLAN-tagged(vlan_id=3)	MATCH
VLAN-tagged(vlan_id=5)	x

Flow Stats Structures

`class ryu.ofproto.ofproto_v1_5_parser.OFPStats` (*length=None*, *_ordered_fields=None*, ***kwargs*)

Flow Stats Structure

This class is implementation of the flow stats structure having compose/query API.

You can define the flow stats by the keyword arguments. The following arguments are available.

Argument	Value	Description
duration	Integer 32bit*2	Time flow entry has been alive. This field is a tuple of two Integer 32bit. The first value is duration_sec and the second is duration_nsec.
idle_time	Integer 32bit*2	Time flow entry has been idle.
flow_count	Integer 32bit	Number of aggregated flow entries.
packet_count	Integer 64bit	Number of packets matched by a flow entry.
byte_count	Integer 64bit	Number of bytes matched by a flow entry.

Example:

```
>>> # compose
>>> stats = parser.OFPStats(
...     packet_count=100,
...     duration=(100, 200)
>>> # query
>>> if 'duration' in stats:
...     print stats['duration']
...
(100, 200)
```

Flow Instruction Structures

`class ryu.ofproto.ofproto_v1_5_parser.OFPInstructionGotoTable` (*table_id*, *type_=None*, *len_=None*)

Goto table instruction

This instruction indicates the next table in the processing pipeline.

Attribute	Description
table_id	Next table

`class ryu.ofproto.ofproto_v1_5_parser.OFPInstructionWriteMetadata` (*metadata*, *metadata_mask*, *type_=None*, *len_=None*)

Write metadata instruction

This instruction writes the masked metadata value into the metadata field.

Attribute	Description
metadata	Metadata value to write
metadata_mask	Metadata write bitmask

class ryu.ofproto.ofproto_v1_5_parser.**OFPIInstructionActions** (*type_*, *actions=None*, *len_=None*)

Actions instruction

This instruction writes/applies/clears the actions.

Attribute	Description
type	One of following values. OFPIT_WRITE_ACTIONS OFPIT_APPLY_ACTIONS OFPIT_CLEAR_ACTIONS
actions	list of OpenFlow action class

type attribute corresponds to type_ parameter of __init__.

class ryu.ofproto.ofproto_v1_5_parser.**OFPIInstructionStatTrigger** (*flags*, *thresholds*, *type_=None*, *len_=None*)

Statistics triggers instruction

This instruction defines a set of statistics thresholds using OXS.

Attribute	Description
flags	Bitmap of the following flags. OFPSTF_PERIODIC OFPSTF_ONLY_FIRST
thresholds	Instance of OFPStats

Action Structures

class ryu.ofproto.ofproto_v1_5_parser.**OFPActionOutput** (*port*, *max_len=65509*, *type_=None*, *len_=None*)

Output action

This action indicates output a packet to the switch port.

Attribute	Description
port	Output port
max_len	Max length to send to controller

class ryu.ofproto.ofproto_v1_5_parser.**OFPActionCopyTtlOut** (*type_=None*, *len_=None*)
Copy TTL Out action

This action copies the TTL from the next-to-outermost header with TTL to the outermost header with TTL.

class ryu.ofproto.ofproto_v1_5_parser.**OFPActionCopyTtlIn** (*type_=None*, *len_=None*)
Copy TTL In action

This action copies the TTL from the outermost header with TTL to the next-to-outermost header with TTL.

class ryu.ofproto.ofproto_v1_5_parser.**OFPActionSetMplsTtl** (*mpls_ttl*, *type_=None*, *len_=None*)

Set MPLS TTL action

This action sets the MPLS TTL.

Attribute	Description
mpls_ttl	MPLS TTL

class ryu.ofproto.ofproto_v1_5_parser.**OFFActionDecMplsTtl** (*type_=None, len_=None*)
 Decrement MPLS TTL action

This action decrements the MPLS TTL.

class ryu.ofproto.ofproto_v1_5_parser.**OFFActionPushVlan** (*ethertype=33024, type_=None, len_=None*)

Push VLAN action

This action pushes a new VLAN tag to the packet.

Attribute	Description
ethertype	Ether type. The default is 802.1Q. (0x8100)

class ryu.ofproto.ofproto_v1_5_parser.**OFFActionPopVlan** (*type_=None, len_=None*)
 Pop VLAN action

This action pops the outermost VLAN tag from the packet.

class ryu.ofproto.ofproto_v1_5_parser.**OFFActionPushMpls** (*ethertype=34887, type_=None, len_=None*)

Push MPLS action

This action pushes a new MPLS header to the packet.

Attribute	Description
ethertype	Ether type

class ryu.ofproto.ofproto_v1_5_parser.**OFFActionPopMpls** (*ethertype=2048, type_=None, len_=None*)

Pop MPLS action

This action pops the MPLS header from the packet.

class ryu.ofproto.ofproto_v1_5_parser.**OFFActionSetQueue** (*queue_id, type_=None, len_=None*)

Set queue action

This action sets the queue id that will be used to map a flow to an already-configured queue on a port.

Attribute	Description
queue_id	Queue ID for the packets

class ryu.ofproto.ofproto_v1_5_parser.**OFFActionGroup** (*group_id=0, type_=None, len_=None*)

Group action

This action indicates the group used to process the packet.

Attribute	Description
group_id	Group identifier

class ryu.ofproto.ofproto_v1_5_parser.**OFFActionSetNwTtl** (*nw_ttl, type_=None, len_=None*)

Set IP TTL action

This action sets the IP TTL.

Attribute	Description
nw_ttl	IP TTL

class ryu.ofproto.ofproto_v1_5_parser.**OFFActionDecNwTtl** (*type_=None, len_=None*)
 Decrement IP TTL action

This action decrements the IP TTL.

class ryu.ofproto.ofproto_v1_5_parser.**OFActionSetField** (*field=None, **kwargs*)
Set field action

This action modifies a header field in the packet.

The set of keywords available for this is same as OFPMatch which including with/without mask.

Example:

```
set_field = OFActionSetField(eth_src="00:00:00:00:00:00")
set_field = OFActionSetField(ipv4_src=("192.168.100.0",
                                       "255.255.255.0"))
```

class ryu.ofproto.ofproto_v1_5_parser.**OFActionPushPbb** (*ethertype, type_=None, len_=None*)

Push PBB action

This action pushes a new PBB header to the packet.

Attribute	Description
ethertype	Ether type

class ryu.ofproto.ofproto_v1_5_parser.**OFActionPopPbb** (*type_=None, len_=None*)
Pop PBB action

This action pops the outermost PBB service instance header from the packet.

class ryu.ofproto.ofproto_v1_5_parser.**OFActionCopyField** (*n_bits=0, src_offset=0, dst_offset=0, oxm_ids=None, type_=None, len_=None*)

Copy Field action

This action copy value between header and register.

At-tribute	Description
n_bits	Number of bits to copy.
src_offset	Starting bit offset in source.
dst_offset	Starting bit offset in destination.
oxm_ids	List of OFPOxmId instances. The first element of this list, src_oxm_id, identifies the field where the value is copied from. The second element of this list, dst_oxm_id, identifies the field where the value is copied to. The default is [].

class ryu.ofproto.ofproto_v1_5_parser.**OFActionMeter** (*meter_id, type_=None, len_=None*)

Meter action

This action applies meter (rate limiter)

Attribute	Description
meter_id	Meter instance

class ryu.ofproto.ofproto_v1_5_parser.**OFActionExperimenter** (*experimenter*)
Experimenter action

This action is an extensible action for the experimenter.

Attribute	Description
experimenter	Experimenter ID

Note: For the list of the supported Nicira experimenter actions, please refer to *ryu.ofproto.nx_actions*.

Controller Status Structure

```
class ryu.ofproto.ofproto_v1_5_parser.OFPControllerStatusStats (short_id=None,
                                                                role=None, reason=None, channel_status=None,
                                                                properties=None, length=None)
```

Controller status structure

Attribute	Description
length	Length of this entry.
short_id	ID number which identifies the controller.
role	Bitmap of controller's role flags. OFPCR_ROLE_NOCHANGE OFPCR_ROLE_EQUAL OFPCR_ROLE_MASTER OFPCR_ROLE_SLAVE
reason	Bitmap of controller status reason flags. OFPCSR_REQUEST OFPCSR_CHANNEL_STATUS OFPCSR_ROLE OFPCSR_CONTROLLER_ADDED OFPCSR_CONTROLLER_REMOVED OFPCSR_SHORT_ID OFPCSR_EXPERIMENTER
channel_status	Bitmap of control channel status flags. OFPCT_STATUS_UP OFPCT_STATUS_DOWN
properties	List of OFPControllerStatusProp subclass instance

2.6 Nicira Extension Structures

2.6.1 Nicira Extension Actions Structures

The followings shows the supported **NXAction classes in OF1.3**, but also available in OF1.2+.

```

class ryu.ofproto.ofproto_v1_3_parser.NXActionRegMove(src_field, dst_field, n_bits,
                                                    src_ofs=0, dst_ofs=0,
                                                    type_=None, len_=None, experi-
                                                    menter=None, subtype=None)

class ryu.ofproto.ofproto_v1_3_parser.NXActionLearn(table_id, specs, idle_timeout=0,
                                                    hard_timeout=0, priority=32768,
                                                    cookie=0,
                                                    flags=0, fin_idle_timeout=0,
                                                    fin_hard_timeout=0, type_=None,
                                                    len_=None, experimenter=None,
                                                    subtype=None)

class ryu.ofproto.ofproto_v1_3_parser.NXActionConjunction(clause, n_clauses, id,
                                                         type_=None, len_=None,
                                                         experimenter=None,
                                                         subtype=None)

class ryu.ofproto.ofproto_v1_3_parser.NXActionResubmitTable(in_port, table_id,
                                                           type_=None,
                                                           len_=None, experi-
                                                           menter=None, sub-
                                                           type=None)

class ryu.ofproto.ofproto_v1_3_parser.NXActionCT(flags, zone_src, zone_ofs_nbits, re-
                                                circ_table, alg, actions, type_=None,
                                                len_=None, experimenter=None, sub-
                                                type=None)

class ryu.ofproto.ofproto_v1_3_parser.NXFlowSpecMatch(src, dst, n_bits)

class ryu.ofproto.ofproto_v1_3_parser.NXFlowSpecLoad(src, dst, n_bits)

class ryu.ofproto.ofproto_v1_3_parser.NXFlowSpecOutput(src, n_bits, dst='')

```

2.6.2 Nicira Extended Match Structures

The API of this class is the same as OFPMatch.

You can define the flow match by the keyword arguments. The following arguments are available.

Argument	Value	Description
eth_dst_nxm	MAC address	Ethernet destination address.
eth_src_nxm	MAC address	Ethernet source address.
tunnel_id_nxm	Integer 64bit	Tunnel identifier.
tun_ipv4_src	IPv4 address	Tunnel IPv4 source address.
tun_ipv4_dst	IPv4 address	Tunnel IPv4 destination address.
pkt_mark	Integer 32bit	Packet metadata mark.
conj_id	Integer 32bit	Conjunction ID used only with the conjunction action
ct_state	Integer 32bit	Contrack state.
ct_zone	Integer 16bit	Contrack zone.
ct_mark	Integer 32bit	Contrack mark.
ct_label	Integer 128bit	Contrack label.
_dp_hash	Integer 32bit	Flow hash computed in Datapath.
reg<idx>	Integer 32bit	Packet register. <idx> is register number 0-7.

2.7 Ryu API Reference

class `ryu.base.app_manager.RyuApp(*_args, **_kwargs)`

The base class for Ryu applications.

RyuApp subclasses are instantiated after ryu-manager loaded all requested Ryu application modules. `__init__` should call `RyuApp.__init__` with the same arguments. It's illegal to send any events in `__init__`.

The instance attribute `'name'` is the name of the class used for message routing among Ryu applications. (Cf. `send_event`) It's set to `__class__.__name__` by `RyuApp.__init__`. It's discouraged for subclasses to override this.

OFF_VERSIONS = None

A list of supported OpenFlow versions for this RyuApp. The default is all versions supported by the framework.

Examples:

```
OFF_VERSIONS = [ofproto_v1_0.OFP_VERSION,
                ofproto_v1_2.OFP_VERSION]
```

If multiple Ryu applications are loaded in the system, the intersection of their `OFF_VERSIONS` is used.

__CONTEXTS = {}

A dictionary to specify contexts which this Ryu application wants to use. Its key is a name of context and its value is an ordinary class which implements the context. The class is instantiated by `app_manager` and the instance is shared among RyuApp subclasses which has `__CONTEXTS` member with the same key. A RyuApp subclass can obtain a reference to the instance via its `__init__`'s `kwargs` as the following.

Example:

```
__CONTEXTS = {
    'network': network.Network
}

def __init__(self, *_args, *_kwargs):
    self.network = kwargs['network']
```

__EVENTS = []

A list of event classes which this RyuApp subclass would generate. This should be specified if and only if event classes are defined in a different python module from the RyuApp subclass is.

close()

teardown method. The method name, `close`, is chosen for python context manager

classmethod context_iteritems()

Return iterator over the (key, contxt class) of application context

reply_to_request (*req, rep*)

Send a reply for a synchronous request sent by `send_request`. The first argument should be an instance of `EventRequestBase`. The second argument should be an instance of `EventReplyBase`.

send_event (*name, ev, state=None*)

Send the specified event to the RyuApp instance specified by name.

send_event_to_observers (*ev, state=None*)

Send the specified event to all observers of this RyuApp.

send_request (*req*)

Make a synchronous request. Set `req.sync` to `True`, send it to a Ryu application specified by `req.dst`,

and block until receiving a reply. Returns the received reply. The argument should be an instance of EventRequestBase.

start ()

Hook that is called after startup initialization is done.

class ryu.controller.dpset.DPSet (*args, **kwargs)

DPSet application manages a set of switches (datapaths) connected to this controller.

get (dp_id)

This method returns the ryu.controller.controller.Datapath instance for the given Datapath ID.

get_all ()

This method returns a list of tuples which represents instances for switches connected to this controller. The tuple consists of a Datapath Id and an instance of ryu.controller.controller.Datapath. A return value looks like the following:

```
[ (dpid_A, Datapath_A), (dpid_B, Datapath_B), ... ]
```

get_port (dpid, port_no)

This method returns the ryu.controller.dpset.PortState instance for the given Datapath ID and the port number. Raises ryu_exc.PortNotFound if no such a datapath connected to this controller or no such a port exists.

get_ports (dpid)

This method returns a list of ryu.controller.dpset.PortState instances for the given Datapath ID. Raises KeyError if no such a datapath connected to this controller.

Configuration

3.1 Setup TLS Connection

If you want to use secure channel to connect OpenFlow switches, you need to use TLS connection. This document describes how to setup Ryu to connect to the Open vSwitch over TLS.

3.1.1 Configuring a Public Key Infrastructure

If you don't have a PKI, the `ovs-pki` script included with Open vSwitch can help you. This section is based on the `INSTALL.SSL` in the Open vSwitch source code.

NOTE: How to install Open vSwitch isn't described in this document. Please refer to the Open vSwitch documents.

Create a PKI by using `ovs-pki` script:

```
% ovs-pki init
(Default directory is /usr/local/var/lib/openvswitch/pki)
```

The `pki` directory consists of `controllerca` and `switchca` subdirectories. Each directory contains CA files.

Create a controller private key and certificate:

```
% ovs-pki req+sign ctl controller
```

`ctl-privkey.pem` and `ctl-cert.pem` are generated in the current directory.

Create a switch private key and certificate:

```
% ovs-pki req+sign sc switch
```

`sc-privkey.pem` and `sc-cert.pem` are generated in the current directory.

3.1.2 Testing TLS Connection

Configuring `ovs-vsctld` to use CA files using the `ovs-vsctl "set-ssl"` command, e.g.:

```
% ovs-vsctl set-ssl /etc/openvswitch/sc-privkey.pem \
  /etc/openvswitch/sc-cert.pem \
  /usr/local/var/lib/openvswitch/pki/controllerca/cacert.pem
% ovs-vsctl add-br br0
% ovs-vsctl set-controller br0 ssl:127.0.0.1:6633
```

Substitute the correct file names, if they differ from the ones used above. You should use absolute file names.

Run Ryu with CA files:

```
% ryu-manager --ctl-privkey ctl-privkey.pem \  
              --ctl-cert ctl-cert.pem \  
              --ca-certs /usr/local/var/lib/openvswitch/pki/switchca/cacert.pem \  
              --verbose
```

You can see something like:

```
loading app ryu.controller.ofp_handler  
instantiating app ryu.controller.ofp_handler  
BRICK ofp_event  
  CONSUMES EventOFPSwitchFeatures  
  CONSUMES EventOFPErrormsg  
  CONSUMES EventOFPHello  
  CONSUMES EventOFPEchoRequest  
connected socket:<SSLSocket fileno=4 sock=127.0.0.1:6633 peer=127.0.0.1:61302> a  
ddress:('127.0.0.1', 61302)  
hello ev <ryu.controller.ofp_event.EventOFPHello object at 0x1047806d0>  
move onto config mode  
switch features ev version: 0x1 msg_type 0x6 xid 0xb0bb34e5 port OFPPhyPort (port  
_no=65534, hw_addr='\x16\xdc\xa2\xe2}K', name='br0\x00\x00\x00\x00\x00\x00\x00\x00\x00\x00\x00\x00\x00\x00\x00\x00', config=0, state=0, curr=0, advertised=0, supported=0, p  
eer=0)  
move onto main mode
```

3.2 Topology Viewer

`ryu.app.gui_topology.gui_topology` provides topology visualization.

This depends on following ryu applications.

<code>ryu.app.rest_topology</code>	Get node and link data.
<code>ryu.app.ws_topology</code>	Being notified change of link up/down.
<code>ryu.app.ofctl_rest</code>	Get flows of datapaths.

3.2.1 Usage

Run mininet (or join your real environment):

```
$ sudo mn --controller remote --topo tree,depth=3
```

Run GUI application:

```
$ PYTHONPATH=. ./bin/ryu run --observe-links ryu/app/gui_topology/gui_topology.py
```

Access <http://<ip address of ryu host>:8080> with your web browser.

3.2.2 Screenshot

Mozilla Firefox (Private Browsing)
 http://192.168.31.202:8080/

Ryu Topology Viewer

```

    graph TD
      S1((dpid: 1)) --- S2((dpid: 2))
      S1 --- S3((dpid: 3))
      S2 --- S4((dpid: 4))
      S2 --- S5((dpid: 5))
      S3 --- S6((dpid: 6))
  
```

- { "actions": ["OUTPUT:65533"], "idle_timeout": 0, "cookie": 0, "packet_count": 18270, "hard_timeout": 0, "byte_count": 931770, "duration_nsec": 119000000, "priority": 65535, "duration_sec": 6114, "table_id": 0, "match": { "dl_type": 35020, "nw_dst": "0.0.0.0", "dl_vlan_pcp": 0, "dl_src": "00:00:00:00:00:00", "tp_src": 0, "dl_vlan": 0, "nw_src": "0.0.0.0", "nw_proto": 0, "tp_dst": 0, "dl_dst": "01:80:c2:00:00:0e", "in_port": 0 } }

4.1 Testing VRRP Module

This page describes how to test Ryu VRRP service

4.1.1 Running integrated tests

Some testing scripts are available.

- `ryu/tests/integrated/test_vrrp_linux_multi.py`
- `ryu/tests/integrated/test_vrrp_multi.py`

Each files include how to run in the comment. Please refer to it.

4.1.2 Running multiple Ryu VRRP in network namespace

The following command lines set up necessary bridges and interfaces.

And then run RYU-VRRP:

```
# ip netns add gateway1
# ip netns add gateway2

# brctl addbr vrrp-br0
# brctl addbr vrrp-br1

# ip link add veth0 type veth peer name veth0-br0
# ip link add veth1 type veth peer name veth1-br0
# ip link add veth2 type veth peer name veth2-br0
# ip link add veth3 type veth peer name veth3-br1
# ip link add veth4 type veth peer name veth4-br1
# ip link add veth5 type veth peer name veth5-br1

# brctl addif vrrp-br0 veth0-br0
# brctl addif vrrp-br0 veth1-br0
# brctl addif vrrp-br0 veth2-br0
# brctl addif vrrp-br1 veth3-br1
# brctl addif vrrp-br1 veth4-br1
# brctl addif vrrp-br1 veth5-br1

# ip link set vrrp-br0 up
```

```
# ip link set vrrp-br1 up

# ip link set veth0 up
# ip link set veth0-br0 up
# ip link set veth1-br0 up
# ip link set veth2-br0 up
# ip link set veth3-br1 up
# ip link set veth4-br1 up
# ip link set veth5 up
# ip link set veth5-br1 up

# ip link set veth1 netns gateway1
# ip link set veth2 netns gateway2
# ip link set veth3 netns gateway1
# ip link set veth4 netns gateway2

# ip netns exec gateway1 ip link set veth1 up
# ip netns exec gateway2 ip link set veth2 up
# ip netns exec gateway1 ip link set veth3 up
# ip netns exec gateway2 ip link set veth4 up

# ip netns exec gateway1 .ryu-vrrp veth1 '10.0.0.2' 254
# ip netns exec gateway2 .ryu-vrrp veth2 '10.0.0.3' 100
```

Caveats

Please make sure that all interfaces and bridges are UP. Don't forget interfaces in netns gateway1/gateway2.

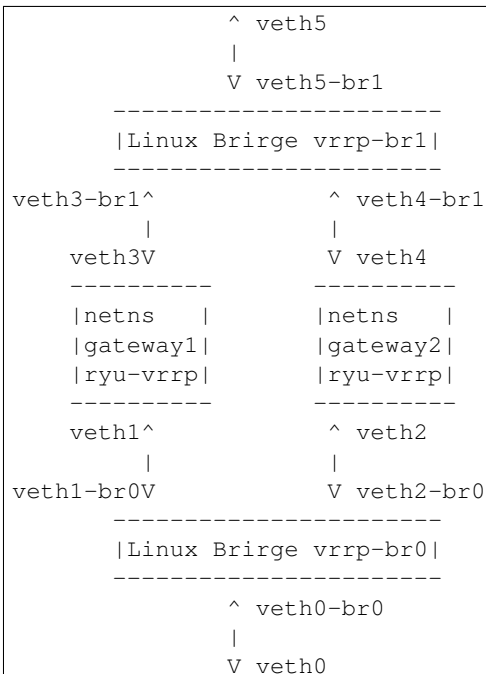

Here's the helper executable, ryu-vrrp:

```
#!/usr/bin/env python
#
# Copyright (C) 2013 Nippon Telegraph and Telephone Corporation.
```

```

# Copyright (C) 2013 Isaku Yamahata <yamahata at valinux co jp>
#
# Licensed under the Apache License, Version 2.0 (the "License");
# you may not use this file except in compliance with the License.
# You may obtain a copy of the License at
#
#     http://www.apache.org/licenses/LICENSE-2.0
#
# Unless required by applicable law or agreed to in writing, software
# distributed under the License is distributed on an "AS IS" BASIS,
# WITHOUT WARRANTIES OR CONDITIONS OF ANY KIND, either express or
# implied.
# See the License for the specific language governing permissions and
# limitations under the License.

from ryu.lib import hub
hub.patch()

# TODO:
#   Right now, we have our own patched copy of ovs python bindings
#   Once our modification is upstreamed and widely deployed,
#   use it
#
# NOTE: this modifies sys.path and thus affects the following imports.
# eg. oslo.config.cfg.
import ryu.contrib

from oslo.config import cfg
import logging
import netaddr
import sys
import time

from ryu import log
log.early_init_log(logging.DEBUG)

from ryu import flags
from ryu import version
from ryu.base import app_manager
from ryu.controller import controller
from ryu.lib import mac as lib_mac
from ryu.lib.packet import vrrp
from ryu.services.protocols.vrrp import api as vrrp_api
from ryu.services.protocols.vrrp import event as vrrp_event

CONF = cfg.CONF

_VRID = 7
_IP_ADDRESS = '10.0.0.1'
_PRIORITY = 100

class VRRPTestRouter(app_manager.RyuApp):
    def __init__(self, *args, **kwargs):
        super(VRRPTestRouter, self).__init__(*args, **kwargs)
        print args
        self.logger.debug('vrrp_config %s', args)

```

```

self._ifname = args[0]
self._primary_ip_address = args[1]
self._priority = int(args[2])

def start(self):
    print 'start'
    hub.spawn(self._main)

def _main(self):
    print self
    interface = vrrp_event.VRRPInterfaceNetworkDevice(
        lib_mac.DONTCARE, self._primary_ip_address, None, self._ifname)
    self.logger.debug('%s', interface)

    ip_addresses = [_IP_ADDRESS]
    config = vrrp_event.VRRPConfig(
        version=vrrp.VRRP_VERSION_V3, vrid=_VRID, priority=self._priority,
        ip_addresses=ip_addresses)
    self.logger.debug('%s', config)

    rep = vrrp_api.vrrp_config(self, interface, config)
    self.logger.debug('%s', rep)

def main():
    vrrp_config = sys.argv[-3:]
    sys.argv = sys.argv[:-3]
    CONF(project='ryu', version='ryu-vrrp %s' % version)

    log.init_log()
    # always enable ofp for now.
    app_lists = ['ryu.services.protocols.vrrp.manager',
                 'ryu.services.protocols.vrrp.dumper',
                 'ryu.services.protocols.vrrp.sample_manager']

    app_mgr = app_manager.AppManager.get_instance()
    app_mgr.load_apps(app_lists)
    contexts = app_mgr.create_contexts()
    app_mgr.instantiate_apps(**contexts)
    vrrp_router = app_mgr.instantiate(VRRPTestRouter, *vrrp_config, **contexts)
    vrrp_router.start()

    while True:
        time.sleep(999999)

    app_mgr.close()

if __name__ == "__main__":
    main()

```

4.2 Testing OF-config support with LINC

This page describes how to setup LINC and test Ryu OF-config with it.

The procedure is as follows. Although all the procedure is written for reader's convenience, please refer to LINC

document for latest informations of LINC.

<https://github.com/FlowForwarding/LINC-Switch>

The test procedure

- install Erlang environment
- build LINC
- configure LINC switch
- setup for LINC
- run LINC switch
- run Ryu test_of_config app

For getting/installing Ryu itself, please refer to <http://osrg.github.io/ryu/>

4.2.1 Install Erlang environment

Since LINC is written in Erlang, you need to install Erlang execution environment. Required version is R15B+.

The easiest way is to use binary package from <https://www.erlang-solutions.com/downloads/download-erlang-otp>

The distribution may also provide Erlang package.

4.2.2 build LINC

install necessary packages for build

install necessary build tools

On Ubuntu:

```
# apt-get install git-core bridge-utils libpcap0.8 libpcap-dev libcap2-bin uml-utilities
```

On RedHat/CentOS:

```
# yum install git sudo bridge-utils libpcap libpcap-devel libcap tuncctl
```

Note that on RedHat/CentOS 5.x you need a newer version of libpcap:

```
# yum erase libpcap libpcap-devel
# yum install flex byacc
# wget http://www.tcpdump.org/release/libpcap-1.2.1.tar.gz
# tar xzf libpcap-1.2.1.tar.gz
# cd libpcap-1.2.1
# ./configure
# make && make install
```

get LINC repo and built

Clone LINC repo:

```
% git clone git://github.com/FlowForwarding/LINC-Switch.git
```

Then compile everything:

```
% cd LINC-Switch
% make
```

Note: At the time of this writing, `test_of_config` fails due to a bug of LINC. You can try this test with LINC which is built by the following methods.

```
% cd LINC-Switch
% make
% cd deps/of_config
% git reset --hard f772af4b765984381ad024ca8e5b5b8c54362638
% cd ../..
% make offline
```

4.2.3 Setup LINC

edit LINC switch configuration file. `rel/linc/releases/0.1/sys.config` Here is the sample `sys.config` for `test_of_config.py` to run.

```
[{linc,
  [{of_config,enabled},
   {capable_switch_ports,
    [{port,1,[{interface,"linc-port"}]},
     {port,2,[{interface,"linc-port2"}]},
     {port,3,[{interface,"linc-port3"}]},
     {port,4,[{interface,"linc-port4"}]}]},
   {capable_switch_queues,
    [
     {queue,991,[{min_rate,10},{max_rate,120}]},
     {queue,992,[{min_rate,10},{max_rate,130}]},
     {queue,993,[{min_rate,200},{max_rate,300}]},
     {queue,994,[{min_rate,400},{max_rate,900}]}
    ]},
   {logical_switches,
    [{switch,0,
      [{backend,linc_us4},
       {controllers,[{"Switch0-Default-Controller","127.0.0.1",6633,tcp}]},
       {controllers_listener,{"127.0.0.1",9998,tcp}},
       {queues_status,enabled},
       {ports,[{port,1,{queues,[]}},{port,2,{queues,[991,992]}]}]}]},
     {switch,7,
      [{backend,linc_us3},
       {controllers,[{"Switch7-Controller","127.0.0.1",6633,tcp}]},
       {controllers_listener,disabled},
       {queues_status,enabled},
       {ports,[{port,4,{queues,[]}},{port,3,{queues,[993,994]}]}]}]}
    ]}],
  {enetconf,
   [{capabilities,
    [{base,{1,0}},
     {base,{1,1}},
     {startup,{1,0}},
     {'writable-running',{1,0}}]},
    {callback_module,linc_ofconfig},
```

```

    {sshd_ip, {127,0,0,1}},
    {sshd_port, 1830},
    {sshd_user_passwords, [{"linc", "linc"}]}},
  {lager,
    [{handlers,
      [{lager_console_backend, debug},
       {lager_file_backend,
        [{"log/error.log", error, 10485760, "$D0", 5},
         {"log/console.log", info, 10485760, "$D0", 5}]}]}]},
  {sasl,
    [{sasl_error_logger, {file, "log/sasl-error.log"}},
     {errlog_type, error},
     {error_logger_mf_dir, "log/sasl"},
     {error_logger_mf_maxbytes, 10485760},
     {error_logger_mf_maxfiles, 5}]},
  {sync, [{excluded_modules, [procket]}]}].

```

4.2.4 setup for LINC

As the above sys.config requires some network interface, create them:

```

# ip link add linc-port type veth peer name linc-port-peer
# ip link set linc-port up
# ip link add linc-port2 type veth peer name linc-port-peer2
# ip link set linc-port2 up
# ip link add linc-port3 type veth peer name linc-port-peer3
# ip link set linc-port3 up
# ip link add linc-port4 type veth peer name linc-port-peer4
# ip link set linc-port4 up

```

After stopping LINC, those created interfaces can be deleted:

```

# ip link delete linc-port
# ip link delete linc-port2
# ip link delete linc-port3
# ip link delete linc-port4

```

4.2.5 Starting LINC OpenFlow switch

Then run LINC:

```

# rel/linc/bin/linc console

```

4.2.6 Run Ryu test_of_config app

Run test_of_config app:

```

# ryu-manager --verbose ryu.tests.integrated.test_of_config ryu.app.rest

```

If you don't install ryu and are working in the git repo directly:

```

# PYTHONPATH=. ./bin/ryu-manager --verbose ryu.tests.integrated.test_of_config ryu.app.rest

```

Using Ryu Network Operating System with OpenStack as OpenFlow controller

Ryu cooperates with OpenStack using Quantum Ryu plugin. The plugin is available in the official Quantum releases.

For more information, please visit <http://github.com/osrg/ryu/wiki/OpenStack> . We described instructions of the installation / configuration of OpenStack with Ryu, and we provide pre-configured VM image to be able to easily try OpenStack with Ryu.

-
- OpenStack: <http://www.openstack.org/>
 - Quantum: <https://github.com/openstack/quantum/>

Snort Intergration

This document describes how to integrate Ryu with Snort.

6.1 Overview

There are two options can send alert to Ryu controller. The Option 1 is easier if you just want to demonstrate or test. Since Snort need very large computation power for analyzing packets you can choose Option 2 to separate them.

[Option 1] Ryu and Snort are on the same machine

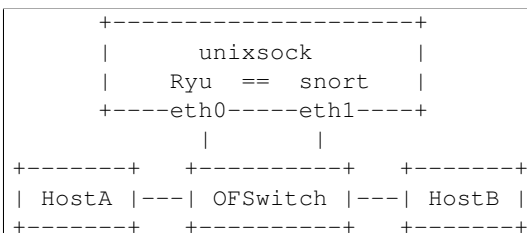

The above depicts Ryu and Snort architecture. Ryu receives Snort alert packet via **Unix Domain Socket** . To monitor packets between HostA and HostB, installing a flow that mirrors packets to Snort.

[Option 2] Ryu and Snort are on the different machines

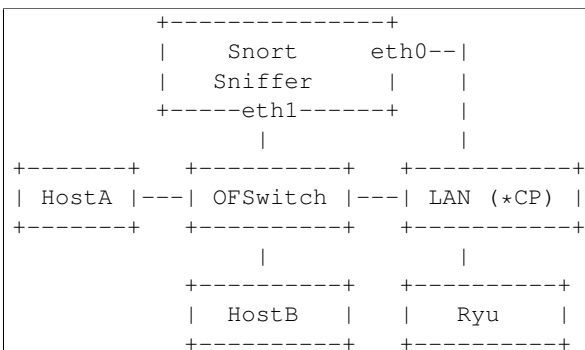

*CP: Control Plane

The above depicts Ryu and Snort architecture. Ryu receives Snort alert packet via **Network Socket** . To monitor packets between HostA and HostB, installing a flow that mirrors packets to Snort.

6.2 Installation Snort

Snort is an open source network intrusion prevention and detection system developed by Sourcefire. If you are not familiar with installing/setting up Snort, please refer to snort setup guides.

<http://www.snort.org/documents>

6.3 Configure Snort

The configuration example is below:

- Add a snort rules file into `/etc/snort/rules` named `Myrules.rules`

```
alert icmp any any -> any any (msg:"Pinging...";sid:1000004;)
alert tcp any any -> any 80 (msg:"Port 80 is accessing"; sid:1000003;)
```

- Add the custom rules in `/etc/snort/snort.conf`

```
include $RULE_PATH/Myrules.rules
```

Configure NIC as a promiscuous mode.

```
$ sudo ifconfig eth1 promisc
```

6.4 Usage

[Option 1]

1. Modify the `simple_switch_snort.py`:

```
socket_config = {'unixsock': True}
# True: Unix Domain Socket Server [Option1]
# False: Network Socket Server [Option2]
```

2. Run Ryu with sample application:

```
$ sudo ./bin/ryu-manager ryu/app/simple_switch_snort.py
```

The incoming packets will all mirror to **port 3** which should be connect to Snort network interface. You can modify the mirror port by assign a new value in the `self.snort_port = 3` of `simple_switch_snort.py`

3. Run Snort:

```
$ sudo -i
$ snort -i eth1 -A unsock -l /tmp -c /etc/snort/snort.conf
```

4. Send an ICMP packet from HostA (192.168.8.40) to HostB (192.168.8.50):

```
$ ping 192.168.8.50
```

5. You can see the result under next section.

[Option 2]

1. Modify the `simple_switch_snort.py`:

```
socket_config = {'unixsock': False}
# True: Unix Domain Socket Server [Option1]
# False: Network Socket Server [Option2]
```

2. Run Ryu with sample application (On the Controller):

```
$ ./bin/ryu-manager ryu/app/simple_switch_snort.py
```

3. Run Snort (On the Snort machine):

```
$ sudo -i
$ snort -i eth1 -A unsock -l /tmp -c /etc/snort/snort.conf
```

4. Run pigrelay.py (On the Snort machine):

```
$ sudo python pigrelay.py
```

This program listening snort alert messages from unix domain socket and sending it to Ryu using network socket.

You can clone the source code from this repo. <https://github.com/John-Lin/pigrelay>

5. Send an ICMP packet from HostA (192.168.8.40) to HostB (192.168.8.50):

```
$ ping 192.168.8.50
```

6. You can see the alert message below:

```
alertmsg: Pinging...
icmp(code=0,csum=19725,data=echo(data=array('B', [97, 98, 99, 100, 101, 102, 103, 104, 105, 106,

ipv4(csum=42562,dst='192.168.8.50',flags=0,header_length=5,identification=724,offset=0,option=N

ethernet(dst='00:23:54:5a:05:14',ethertype=2048,src='00:23:54:6c:1d:17')
```

```

alertmsg: Pinging...
icmp(code=0,csum=21773,data=echo(data=array('B', [97, 98, 99, 100, 101, 102, 103, 104, 105, 106,

ipv4(csum=52095,dst='192.168.8.40',flags=0,header_length=5,identification=7575,offset=0,option=N
```

Built-in Ryu applications

Ryu has some built-in Ryu applications. Some of them are examples. Others provide some functionalities to other Ryu applications.

7.1 ryu.app.ofctl

ryu.app.ofctl provides a convenient way to use OpenFlow messages synchronously.

OfctlService ryu application is automatically loaded if your Ryu application imports ofctl.api module.

Example:

```
import ryu.app.ofctl.api
```

OfctlService application internally uses OpenFlow barrier messages to ensure message boundaries. **As OpenFlow messages are asynchronous and some of messages does not have any replies on success, barriers are necessary for correct error handling.**

7.1.1 api module

`ryu.app.ofctl.api.get_datapath` (*app*, *dpid*)
Get datapath object by dpid.

Parameters

- **app** – Client RyuApp instance
- **dpid** – Datapath-id (in integer)

Returns None on error.

`ryu.app.ofctl.api.send_msg` (*app*, *msg*, *reply_cls=None*, *reply_multi=False*)
Send an OpenFlow message and wait for reply messages.

Parameters

- **app** – Client RyuApp instance
- **msg** – An OpenFlow controller-to-switch message to send
- **reply_cls** – OpenFlow message class for expected replies. None means no replies are expected. The default is None.
- **reply_multi** – True if multipart replies are expected. The default is False.

If no replies, returns None. If `reply_multi=False`, returns OpenFlow switch-to-controller message. If `reply_multi=True`, returns a list of OpenFlow switch-to-controller messages.

Raise an exception on error.

Example:

```
import ryu.app.ofctl.api as api

msg = parser.OFPPortDescStatsRequest(datapath=datapath)
result = api.send_msg(self, msg,
                      reply_cls=parser.OFPPortDescStatsReply,
                      reply_multi=True)
```

7.1.2 exceptions

exception `ryu.app.ofctl.exception.InvalidDatapath` (*result*)
Datapath is invalid.

This can happen when the bridge disconnects.

exception `ryu.app.ofctl.exception.OFError` (*result*)
OFErrorMsg is received.

exception `ryu.app.ofctl.exception.UnexpectedMultiReply` (*result*)
Two or more replies are received for `reply_multi=False` request.

7.2 ryu.app.ofctl_rest

`ryu.app.ofctl_rest` provides REST APIs for retrieving the switch stats and Updating the switch stats. This application helps you debug your application and get various statistics.

This application supports OpenFlow version 1.0, 1.2 and 1.3.

Contents

- *ryu.app.ofctl_rest*
 - *Retrieve the switch stats*
 - * *Get all switches*
 - * *Get the desc stats*
 - * *Get all flows stats*
 - * *Get flows stats filtered by fields*
 - * *Get aggregate flow stats*
 - * *Get aggregate flow stats filtered by fields*
 - * *Get table stats*
 - * *Get table features*
 - * *Get ports stats*
 - * *Get ports description*
 - * *Get queues stats*
 - * *Get queues config*
 - * *Get groups stats*
 - * *Get group description stats*
 - * *Get group features stats*
 - * *Get meters stats*
 - * *Get meter config stats*
 - * *Get meter features stats*
 - *Update the switch stats*
 - * *Add a flow entry*
 - * *Modify all matching flow entries*
 - * *Modify flow entry strictly*
 - * *Delete all matching flow entries*
 - * *Delete flow entry strictly*
 - * *Delete all flow entries*
 - * *Add a group entry*
 - * *Modify a group entry*
 - * *Delete a group entry*
 - * *Modify the behavior of the port*
 - * *Add a meter entry*
 - * *Modify a meter entry*
 - * *Delete a meter entry*
 - *Support for experimenter multipart*
 - * *Send a experimenter message*
 - *Reference: Description of Match and Actions*
 - * *Description of Match on request messages*
 - * *Description of Actions on request messages*

7.2.1 Retrieve the switch stats**Get all switches**

Get the list of all switches which connected to the controller.

Usage:

Method	GET
URI	/stats/switches

Response message body:

Attribute	Description	Example
dpid	Datapath ID	1

Example of use:

```
$ curl -X GET http://localhost:8080/stats/switches
```

```
[
  1,
  2,
  3
]
```

Note: The result of the REST command is formatted for easy viewing.

Get the desc stats

Get the desc stats of the switch which specified with Datapath ID in URI.

Usage:

Method	GET
URI	/stats/desc/<dpid>

Response message body:

Attribute	Description	Example
dpid	Datapath ID	"1"
mfr_desc	Manufacturer description	"Nicira, Inc.",
hw_desc	Hardware description	"Open vSwitch",
sw_desc	Software description	"2.3.90",
serial_num	Serial number	"None",
dp_desc	Human readable description of datapath	"None"

Example of use:

```
$ curl -X GET http://localhost:8080/stats/desc/1
```

```
{
  "1": {
    "mfr_desc": "Nicira, Inc.",
    "hw_desc": "Open vSwitch",
    "sw_desc": "2.3.90",
    "serial_num": "None",
    "dp_desc": "None"
  }
}
```

Get all flows stats

Get all flows stats of the switch which specified with Datapath ID in URI.

Usage:

Method	GET
URI	/stats/flow/<dpid>

Response message body:

Attribute	Description	Example
dpid	Datapath ID	"1"
length	Length of this entry	88
table_id	Table ID	0
duration_sec	Time flow has been alive in seconds	2
duration_nsec	Time flow has been alive in nanoseconds beyond duration_sec	6.76e+08
priority	Priority of the entry	11111
idle_timeout	Number of seconds idle before expiration	0
hard_timeout	Number of seconds before expiration	0
flags	Bitmap of OFPPF_* flags	1
cookie	Opaque controller-issued identifier	1
packet_count	Number of packets in flow	0
byte_count	Number of bytes in flow	0
match	Fields to match	{"in_port": 1}
actions	Instruction set	["OUTPUT:2"]

Example of use:

```
$ curl -X GET http://localhost:8080/stats/flow/1
```

```
{
  "1": [
    {
      "length": 88,
      "table_id": 0,
      "duration_sec": 2,
      "duration_nsec": 6.76e+08,
      "priority": 11111,
      "idle_timeout": 0,
      "hard_timeout": 0,
      "flags": 1,
      "cookie": 1,
      "packet_count": 0,
      "byte_count": 0,
      "match": {
        "in_port": 1
      },
      "actions": [
        "OUTPUT:2"
      ]
    }
  ]
}
```

Get flows stats filtered by fields

Get flows stats of the switch filtered by the OFPFlowStats fields. This is POST method version of *Get all flows stats*.

Usage:

Method	POST
URI	/stats/flow/<dpid>

Request message body:

Attribute	Description	Example	Default
table_id	Table ID (int)	0	OF-PTT_ALL
out_port	Require matching entries to include this as an output port (int)	2	OFPP_ANY
out_group	Require matching entries to include this as an output group (int)	1	OFPG_ANY
cookie	Require matching entries to contain this cookie value (int)	1	0
cookie_mask	Mask used to restrict the cookie bits that must match (int)	1	0
match	Fields to match (dict)	{"in_port": 1}	{ } #wild-carded

Response message body: The same as *Get all flows stats*

Example of use:

```
$ curl -X POST -d '{
  "table_id": 0,
  "out_port": 2,
  "cookie": 1,
  "cookie_mask": 1,
  "match": {
    "in_port": 1
  }
}' http://localhost:8080/stats/flow/1
```

```
{
  "1": [
    {
      "table_id": 0,
      "duration_sec": 2,
      "duration_nsec": 6.76e+08,
      "priority": 11111,
      "idle_timeout": 0,
      "hard_timeout": 0,
      "cookie": 1,
      "packet_count": 0,
      "byte_count": 0,
      "match": {
        "in_port": 1
      },
      "actions": [
        "OUTPUT:2"
      ]
    }
  ]
}
```

Get aggregate flow stats

Get aggregate flow stats of the switch which specified with Datapath ID in URI.

Usage:

Method	GET
URI	/stats/aggregateflow/<dpid>

Response message body:

Attribute	Description	Example
dpid	Datapath ID	"1"
packet_count	Number of packets in flows	18
byte_count	Number of bytes in flows	756
flow_count	Number of flows	3

Example of use:

```
$ curl -X GET http://localhost:8080/stats/aggregateflow/1
```

```
{
  "1": [
    {
      "packet_count": 18,
      "byte_count": 756,
      "flow_count": 3
    }
  ]
}
```

Get aggregate flow stats filtered by fields

Get aggregate flow stats of the switch filtered by the OFPAggregateStats fields. This is POST method version of *Get aggregate flow stats*.

Usage:

Method	POST
URI	/stats/aggregateflow/<dpid>

Request message body:

Attribute	Description	Example	Default
table_id	Table ID (int)	0	OF-PTT_ALL
out_port	Require matching entries to include this as an output port (int)	2	OFPP_ANY
out_group	Require matching entries to include this as an output group (int)	1	OFPG_ANY
cookie	Require matching entries to contain this cookie value (int)	1	0
cookie_mask	Mask used to restrict the cookie bits that must match (int)	1	0
match	Fields to match (dict)	{"in_port": 1}	{ } #wild-carded

Response message body: The same as *Get aggregate flow stats*

Example of use:

```
$ curl -X POST -d '{
  "table_id": 0,
```

```

    "out_port": 2,
    "cookie": 1,
    "cookie_mask": 1,
    "match":{
        "in_port":1
    }
}' http://localhost:8080/stats/aggregateflow/1

```

```

{
  "1": [
    {
      "packet_count": 18,
      "byte_count": 756,
      "flow_count": 3
    }
  ]
}

```

Get table stats

Get table stats of the switch which specified with Datapath ID in URI.

Usage:

Method	GET
URI	/stats/table/<dpid>

Response message body(OpenFlow1.0):

Attribute	Description	Example
dpid	Datapath ID	"1"
table_id	Table ID	0
name	Name of Table	"classifier"
max_entries	Max number of entries supported	1e+06
wildcards	Bitmap of OFPFW_* wildcards that are supported by the table	["IN_PORT","DL_VLAN"]
ac-tive_count	Number of active entries	0
lookup_count	Number of packets looked up in table	8
matched_count	Number of packets that hit table	0

Response message body(OpenFlow1.2):

Attribute	Description	Example
dpid	Datapath ID	"1"
table_id	Table ID	0
name	Name of Table	"classifier"
match	Bitmap of (1 << OFPXMT_*) that indicate the fields the table can match on	["OFB_IN_PORT","OFB_METADATA"]
wild-cards	Bitmap of (1 << OFPXMT_*) wildcards that are supported by the table	["OFB_IN_PORT","OFB_METADATA"]
write_actions	Bitmap of OFPAT_* that are supported by the table with OFPIT_WRITE_ACTIONS	["OUT-PUT","SET_MPLS_TTL"]
apply_actions	Bitmap of OFPAT_* that are supported by the table with OFPIT_APPLY_ACTIONS	["OUT-PUT","SET_MPLS_TTL"]
write_setfields	Bitmap of (1 << OFPXMT_*) header fields that can be set with OFPIT_WRITE_ACTIONS	["OFB_IN_PORT","OFB_METADATA"]
apply_setfields	Bitmap of (1 << OFPXMT_*) header fields that can be set with OFPIT_APPLY_ACTIONS	["OFB_IN_PORT","OFB_METADATA"]
meta-data_match	Bits of metadata table can match	18446744073709552000
meta-data_write	Bits of metadata table can write	18446744073709552000
instructions	Bitmap of OFPIT_* values supported	["GOTO_TABLE","WRITE_METADATA"]
config	Bitmap of OFPTC_* values	[]
max_entries	Max number of entries supported	1e+06
active_count	Number of active entries	0
lookup_count	Number of packets looked up in table	0
matched_count	Number of packets that hit table	8

Response message body(OpenFlow1.3):

Attribute	Description	Example
dpid	Datapath ID	"1"
table_id	Table ID	0
active_count	Number of active entries	0
lookup_count	Number of packets looked up in table	8
matched_count	Number of packets that hit table	0

Example of use:

```
$ curl -X GET http://localhost:8080/stats/table/1
```

Response (OpenFlow1.0):

```
{
  "1": [
    {
      "table_id": 0,
      "lookup_count": 8,
      "max_entries": 1e+06,
      "active_count": 0,
      "name": "classifier",
      "matched_count": 0,
      "wildcards": [
        "IN_PORT",
        "DL_VLAN"
      ]
    }
  ]
}
```

```

    ]
  },
  ...
  {
    "table_id": 253,
    "lookup_count": 0,
    "max_entries": 1e+06,
    "active_count": 0,
    "name": "table253",
    "matched_count": 0,
    "wildcards": [
      "IN_PORT",
      "DL_VLAN"
    ]
  }
]
}

```

Response (OpenFlow1.2):

```

{
  "1": [
    {
      "apply_setfields": [
        "OFB_IN_PORT",
        "OFB_METADATA"
      ],
      "match": [
        "OFB_IN_PORT",
        "OFB_METADATA"
      ],
      "metadata_write": 18446744073709552000,
      "config": [],
      "instructions": [
        "GOTO_TABLE",
        "WRITE_METADATA"
      ],
      "table_id": 0,
      "metadata_match": 18446744073709552000,
      "lookup_count": 8,
      "wildcards": [
        "OFB_IN_PORT",
        "OFB_METADATA"
      ],
      "write_setfields": [
        "OFB_IN_PORT",
        "OFB_METADATA"
      ],
      "write_actions": [
        "OUTPUT",
        "SET_MPLS_TTL"
      ],
      "name": "classifier",
      "matched_count": 0,
      "apply_actions": [
        "OUTPUT",
        "SET_MPLS_TTL"
      ],
      "active_count": 0,
    }
  ]
}

```

```

    "max_entries": 1e+06
  },
  ...
  {
    "apply_setfields": [
      "OFB_IN_PORT",
      "OFB_METADATA"
    ],
    "match": [
      "OFB_IN_PORT",
      "OFB_METADATA"
    ],
    "metadata_write": 18446744073709552000,
    "config": [],
    "instructions": [
      "GOTO_TABLE",
      "WRITE_METADATA"
    ],
    "table_id": 253,
    "metadata_match": 18446744073709552000,
    "lookup_count": 0,
    "wildcards": [
      "OFB_IN_PORT",
      "OFB_METADATA"
    ],
    "write_setfields": [
      "OFB_IN_PORT",
      "OFB_METADATA"
    ],
    "write_actions": [
      "OUTPUT",
      "SET_MPLS_TTL"
    ],
    "name": "table253",
    "matched_count": 0,
    "apply_actions": [
      "OUTPUT",
      "SET_MPLS_TTL"
    ],
    "active_count": 0,
    "max_entries": 1e+06
  }
]
}

```

Response (OpenFlow1.3):

```

{
  "1": [
    {
      "active_count": 0,
      "table_id": 0,
      "lookup_count": 8,
      "matched_count": 0
    },
    ...
    {
      "active_count": 0,
      "table_id": 253,

```

```

    "lookup_count": 0,
    "matched_count": 0
  }
]
}

```

Get table features

Get table features of the switch which specified with Datapath ID in URI.

Usage:

Method	GET
URI	/stats/tablefeatures/<dpid>

Response message body:

Attribute	Description	Example
dpid	Datapath ID	"1"
table_id	Table ID	0
name	Name of Table	"table_0"
meta-data_match	Bits of metadata table can match	18446744073709552000
meta-data_write	Bits of metadata table can write	18446744073709552000
config	Bitmap of OFPTC_* values	0
max_entries	Max number of entries supported	4096
properties	struct ofp_table_feature_prop_header	[{"type": "INSTRUCTIONS", "instruction_ids": [...]},...]

Example of use:

```
$ curl -X GET http://localhost:8080/stats/tablefeatures/1
```

```

{
  "1": [
    {
      "metadata_write": 18446744073709552000,
      "config": 0,
      "table_id": 0,
      "metadata_match": 18446744073709552000,
      "max_entries": 4096,
      "properties": [
        {
          "type": "INSTRUCTIONS",
          "instruction_ids": [
            {
              "len": 4,
              "type": 1
            },
            ...
          ]
        },
        ...
      ]
    },
    ...
  ],
}

```

```

    "name": "table_0"
  },
  {
    "metadata_write": 18446744073709552000,
    "config": 0,
    "table_id": 1,
    "metadata_match": 18446744073709552000,
    "max_entries": 4096,
    "properties": [
      {
        "type": "INSTRUCTIONS",
        "instruction_ids": [
          {
            "len": 4,
            "type": 1
          },
          ...
        ]
      },
      ...
    ],
    "name": "table_1"
  },
  ...
]
}

```

Get ports stats

Get ports stats of the switch which specified with Datapath ID in URI.

Usage:

Method	GET
URI	/stats/port/<dpid>

Response message body:

Attribute	Description	Example
dpid	Datapath ID	"1"
port_no	Port number	1
rx_packets	Number of received packets	9
tx_packets	Number of transmitted packets	6
rx_bytes	Number of received bytes	738
tx_bytes	Number of transmitted bytes	252
rx_dropped	Number of packets dropped by RX	0
tx_dropped	Number of packets dropped by TX	0
rx_errors	Number of receive errors	0
tx_errors	Number of transmit errors	0
rx_frame_err	Number of frame alignment errors	0
rx_over_err	Number of packets with RX overrun	0
rx_crc_err	Number of CRC errors	0
collisions	Number of collisions	0
duration_sec	Time port has been alive in seconds	12
duration_nsec	Time port has been alive in nanoseconds beyond duration_sec	9.76e+08

Example of use:

```
$ curl -X GET http://localhost:8080/stats/port/1
```

```
{
  "1": [
    {
      "port_no": 1,
      "rx_packets": 9,
      "tx_packets": 6,
      "rx_bytes": 738,
      "tx_bytes": 252,
      "rx_dropped": 0,
      "tx_dropped": 0,
      "rx_errors": 0,
      "tx_errors": 0,
      "rx_frame_err": 0,
      "rx_over_err": 0,
      "rx_crc_err": 0,
      "collisions": 0,
      "duration_sec": 12,
      "duration_nsec": 9.76e+08
    },
    {
      :
      :
    }
  ]
}
```

Get ports description

Get ports description of the switch which specified with Datapath ID in URI.

Usage:

Method	GET
URI	/stats/portdesc/<dpid>

Response message body:

Attribute	Description	Example
dpid	Datapath ID	"1"
port_no	Port number	1
hw_addr	Ethernet hardware address	"0a:b6:d0:0c:e1:d7"
name	Name of port	"s1-eth1"
config	Bitmap of OFPPC_* flags	0
state	Bitmap of OFPPS_* flags	0
curr	Current features	2112
advertised	Features being advertised by the port	0
supported	Features supported by the port	0
peer	Features advertised by peer	0
curr_speed	Current port bitrate in kbps	1e+07
max_speed	Max port bitrate in kbps	0

Example of use:

```
$ curl -X GET http://localhost:8080/stats/portdesc/1
```

```
{
  "1": [
    {
      "port_no": 1,
      "hw_addr": "0a:b6:d0:0c:e1:d7",
      "name": "s1-eth1",
      "config": 0,
      "state": 0,
      "curr": 2112,
      "advertised": 0,
      "supported": 0,
      "peer": 0,
      "curr_speed": 1e+07,
      "max_speed": 0
    },
    {
      :
      :
    }
  ]
}
```

Get queues stats

Get queues stats of the switch which specified with Datapath ID in URI.

Usage:

Method	GET
URI	/stats/queue/<dpid>

Response message body:

Attribute	Description	Example
dpid	Datapath ID	"1"
port_no	Port number	1
queue_id	Queue ID	0
tx_bytes	Number of transmitted bytes	0
tx_packets	Number of transmitted packets	0
tx_errors	Number of packets dropped due to overrun	0
duration_sec	Time queue has been alive in seconds	4294963425
duration_nsec	Time queue has been alive in nanoseconds beyond duration_sec	3912967296

Example of use:

```
$ curl -X GET http://localhost:8080/stats/queue/1
```

```
{
  "1": [
    {
      "port_no": 1,
      "queue_id": 0,
      "tx_bytes": 0,
      "tx_packets": 0,
      "tx_errors": 0,
      "duration_sec": 4294963425,
      "duration_nsec": 3912967296
    },
    {
      "port_no": 1,
      "queue_id": 1,
      "tx_bytes": 0,
      "tx_packets": 0,
      "tx_errors": 0,
      "duration_sec": 4294963425,
      "duration_nsec": 3912967296
    }
  ]
}
```

Get queues config

Get queues config of the switch which specified with Datapath ID and Port in URI.

Usage:

Method	GET
URI	/stats/queueconfig/<dpid>/<port>

Response message body:

Attribute	Description	Example
dpid	Datapath ID	"1"
port	Port which was queried	1
queues	struct of p_packet_queue	
- queue_id	ID for the specific queue	2
- port	Port this queue is attached to	0
- properties	struct of p_queue_prop_header properties	[{"property": "MIN_RATE", "rate": 80}]

Example of use:

```
$ curl -X GET http://localhost:8080/stats/queueconfig/1/1
```

```
{
  "1": [
    {
      "port": 1,
      "queues": [
        {
          "properties": [
            {
              "property": "MIN_RATE",
              "rate": 80
            }
          ],
          "port": 0,
          "queue_id": 1
        },
        {
          "properties": [
            {
              "property": "MAX_RATE",
              "rate": 120
            }
          ],
          "port": 2,
          "queue_id": 2
        },
        {
          "properties": [
            {
              "property": "EXPERIMENTER",
              "data": [],
              "experimenter": 999
            }
          ],
          "port": 3,
          "queue_id": 3
        }
      ]
    }
  ]
}
```

Get groups stats

Get groups stats of the switch which specified with Datapath ID in URI.

Usage:

Method	GET
URI	/stats/group/<dpid>

Response message body:

Attribute	Description	Example
dpid	Datapath ID	"1"
length	Length of this entry	56
group_id	Group ID	1
ref_count	Number of flows or groups that directly forward to this group	1
packet_count	Number of packets processed by group	0
byte_count	Number of bytes processed by group	0
duration_sec	Time group has been alive in seconds	161
duration_nsec	Time group has been alive in nanoseconds beyond duration_sec	3.03e+08
bucket_stats	struct ofp_bucket_counter	
- packet_count	Number of packets processed by bucket	0
- byte_count	Number of bytes processed by bucket	0

Example of use:

```
$ curl -X GET http://localhost:8080/stats/group/1
```

```
{
  "1": [
    {
      "length": 56,
      "group_id": 1,
      "ref_count": 1,
      "packet_count": 0,
      "byte_count": 0,
      "duration_sec": 161,
      "duration_nsec": 3.03e+08,
      "bucket_stats": [
        {
          "packet_count": 0,
          "byte_count": 0
        }
      ]
    }
  ]
}
```

Get group description stats

Get group description stats of the switch which specified with Datapath ID in URI.

Usage:

Method	GET
URI	/stats/groupdesc/<dpid>

Response message body:

Attribute	Description	Example
dpid	Datapath ID	"1"
type	One of OFPGT_*	"ALL"
group_id	Group ID	1
buckets	struct ofp_bucket	
- weight	Relative weight of bucket (Only defined for select groups)	0
- watch_port	Port whose state affects whether this bucket is live (Only required for fast failover groups)	4294967295
- watch_group	Group whose state affects whether this bucket is live (Only required for fast failover groups)	4294967295
- actions	0 or more actions associated with the bucket	['OUTPUT:1']

Example of use:

```
$ curl -X GET http://localhost:8080/stats/groupdesc/1
```

```
{
  "1": [
    {
      "type": "ALL",
      "group_id": 1,
      "buckets": [
        {
          "weight": 0,
          "watch_port": 4294967295,
          "watch_group": 4294967295,
          "actions": [
            "OUTPUT:1"
          ]
        }
      ]
    }
  ]
}
```

Get group features stats

Get group features stats of the switch which specified with Datapath ID in URI.

Usage:

Method	GET
URI	/stats/groupfeatures/<dpid>

Response message body:

Attribute	Description	Example
dpid	Datapath ID	"1"
types	Bitmap of (1 << OFPGT_*) values supported	[]
capabilities	Bitmap of OFPGFC_* capability supported	["SELECT_WEIGHT", "SELECT_LIVENESS", "CHAINING"]
max_groups	Maximum number of groups for each type	[{"ALL": 4294967040}, ...]
actions	Bitmaps of (1 << OFPAT_*) values supported	[{"ALL": ["OUTPUT", ...]}, ...]

Example of use:

```
$ curl -X GET http://localhost:8080/stats/groupfeatures/1
```

```
{
  "1": [
    {
      "types": [],
      "capabilities": [
        "SELECT_WEIGHT",
        "SELECT_LIVENESS",
        "CHAINING"
      ],
      "max_groups": [
        {
          "ALL": 4294967040
        },
        {
          "SELECT": 4294967040
        },
        {
          "INDIRECT": 4294967040
        },
        {
          "FF": 4294967040
        }
      ],
      "actions": [
        {
          "ALL": [
            "OUTPUT",
            "COPY_TTL_OUT",
            "COPY_TTL_IN",
            "SET_MPLS_TTL",
            "DEC_MPLS_TTL",
            "PUSH_VLAN",
            "POP_VLAN",
            "PUSH_MPLS",
            "POP_MPLS",
            "SET_QUEUE",
            "GROUP",
            "SET_NW_TTL",
            "DEC_NW_TTL",
            "SET_FIELD"
          ]
        }
      ]
    }
  ],
}
```

```

    {
      "SELECT": []
    },
    {
      "INDIRECT": []
    },
    {
      "FF": []
    }
  ]
}

```

Get meters stats

Get meters stats of the switch which specified with Datapath ID in URI.

Usage:

Method	GET
URI	/stats/meter/<dpid>

Response message body:

Attribute	Description	Example
dpid	Datapath ID	"1"
meter_id	Meter ID	1
len	Length in bytes of this stats	56
flow_count	Number of flows bound to meter	0
packet_in_count	Number of packets in input	0
byte_in_count	Number of bytes in input	0
duration_sec	Time meter has been alive in seconds	37
duration_nsec	Time meter has been alive in nanoseconds beyond duration_sec	988000
band_stats	struct of fp_meter_band_stats	
-	Number of packets in band	0
- packet_band_count		
- byte_band_count	Number of bytes in band	0

Example of use:

```
$ curl -X GET http://localhost:8080/stats/meter/1
```

```

{
  "1": [
    {
      "meter_id": 1,
      "len": 56,
      "flow_count": 0,
      "packet_in_count": 0,
      "byte_in_count": 0,
      "duration_sec": 37,
      "duration_nsec": 988000,
      "band_stats": [
        {

```

```

        "packet_band_count": 0,
        "byte_band_count": 0
    }
  ]
}

```

Get meter config stats

Get meter config stats of the switch which specified with Datapath ID in URI.

Usage:

Method	GET
URI	/stats/meterconfig/<dpid>

Response message body:

Attribute	Description	Example
dpid	Datapath ID	"1"
flags	All OFPMC_* that apply	"KBPS"
meter_id	Meter ID	1
bands	struct ofp_meter_band_header	
- type	One of OFPMBT_*	"DROP"
- rate	Rate for this band	1000
- burst_size	Size of bursts	0

Example of use:

```
$ curl -X GET http://localhost:8080/stats/meterconfig/1
```

```

{
  "1": [
    {
      "flags": [
        "KBPS"
      ],
      "meter_id": 1,
      "bands": [
        {
          "type": "DROP",
          "rate": 1000,
          "burst_size": 0
        }
      ]
    }
  ]
}

```

Get meter features stats

Get meter features stats of the switch which specified with Datapath ID in URI.

Usage:

Method	GET
URI	/stats/meterfeatures/<dpid>

Response message body:

Attribute	Description	Example
dpid	Datapath ID	"1"
max_meter	Maximum number of meters	256
band_types	Bitmaps of (1 << OFPMBT_*) values supported	["DROP"]
capabilities	Bitmaps of "ofp_meter_flags"	["KBPS", "BURST", "STATS"]
max_bands	Maximum bands per meters	16
max_color	Maximum color value	8

Example of use:

```
$ curl -X GET http://localhost:8080/stats/meterfeatures/1
```

```
{
  "1": [
    {
      "max_meter": 256,
      "band_types": [
        "DROP"
      ],
      "capabilities": [
        "KBPS",
        "BURST",
        "STATS"
      ],
      "max_bands": 16,
      "max_color": 8
    }
  ]
}
```

7.2.2 Update the switch stats

Add a flow entry

Add a flow entry to the switch.

Usage:

Method	POST
URI	/stats/flowentry/add

Request message body:

At-tribute	Description	Example	Default
dpid	Datapath ID (int)	1	(Mandatory)
cookie	Opaque controller-issued identifier (int)	1	0
cookie_mask	Mask used to restrict the cookie bits (int)	1	0
table_id	Table ID to put the flow in (int)	0	0
idle_timeout	Idle time before discarding (seconds) (int)	30	0
hard_timeout	Max time before discarding (seconds) (int)	30	0
priority	Priority level of flow entry (int)	11111	0
buffer_id	Buffered packet to apply to, or OFP_NO_BUFFER (int)	1	OFP_NO_BUFFER
flags	Bitmap of OFPFF_* flags (int)	1	0
match	Fields to match (dict)	{"in_port":1}	{} #wildcarded
actions	Instruction set (list of dict)	[{"type":"OUTPUT", "port":2}]	[] #DROP

Note: For description of match and actions, please see *Reference: Description of Match and Actions*.

Example of use:

```
$ curl -X POST -d '{
  "dpid": 1,
  "cookie": 1,
  "cookie_mask": 1,
  "table_id": 0,
  "idle_timeout": 30,
  "hard_timeout": 30,
  "priority": 11111,
  "flags": 1,
  "match":{
    "in_port":1
  },
  "actions":[
    {
      "type":"OUTPUT",
      "port": 2
    }
  ]
}' http://localhost:8080/stats/flowentry/add
```

```
$ curl -X POST -d '{
  "dpid": 1,
  "priority": 22222,
  "match":{
    "in_port":1
  },
  "actions":[
    {
      "type":"GOTO_TABLE",
      "table_id": 1
    }
  ]
}' http://localhost:8080/stats/flowentry/add
```

```
]
}' http://localhost:8080/stats/flowentry/add
```

```
$ curl -X POST -d '{
  "dpid": 1,
  "priority": 33333,
  "match":{
    "in_port":1
  },
  "actions":[
    {
      "type":"WRITE_METADATA",
      "metadata": 1,
      "metadata_mask": 1
    }
  ]
}' http://localhost:8080/stats/flowentry/add
```

```
$ curl -X POST -d '{
  "dpid": 1,
  "priority": 44444,
  "match":{
    "in_port":1
  },
  "actions":[
    {
      "type":"METER",
      "meter_id": 1
    }
  ]
}' http://localhost:8080/stats/flowentry/add
```

Note: To confirm flow entry registration, please see *Get all flows stats* or *Get flows stats filtered by fields*.

Modify all matching flow entries

Modify all matching flow entries of the switch.

Usage:

Method	POST
URI	/stats/flowentry/modify

Request message body:

Attribute	Description	Example	Default
dpid	Datapath ID (int)	1	(Mandatory)
cookie	Opaque controller-issued identifier (int)	1	0
cookie_mask	Mask used to restrict the cookie bits (int)	1	0
table_id	Table ID to put the flow in (int)	0	0
idle_timeout	Idle time before discarding (seconds) (int)	30	0
hard_timeout	Max time before discarding (seconds) (int)	30	0
priority	Priority level of flow entry (int)	11111	0
buffer_id	Buffered packet to apply to, or OFP_NO_BUFFER (int)	1	OFP_NO_BUFFER
flags	Bitmap of OFPFF_* flags (int)	1	0
match	Fields to match (dict)	{"in_port":1}	{} #wildcarded
actions	Instruction set (list of dict)	[{"type":"OUTPUT", "port":2}]	[] #DROP

Example of use:

```
$ curl -X POST -d '{
  "dpid": 1,
  "cookie": 1,
  "cookie_mask": 1,
  "table_id": 0,
  "idle_timeout": 30,
  "hard_timeout": 30,
  "priority": 11111,
  "flags": 1,
  "match":{
    "in_port":1
  },
  "actions":[
    {
      "type":"OUTPUT",
      "port": 2
    }
  ]
}' http://localhost:8080/stats/flowentry/modify
```

Modify flow entry strictly

Modify flow entry strictly matching wildcards and priority

Usage:

Method	POST
URI	/stats/flowentry/modify_strict

Request message body:

Attribute	Description	Example	Default
dpid	Datapath ID (int)	1	(Mandatory)
cookie	Opaque controller-issued identifier (int)	1	0
cookie_mask	Mask used to restrict the cookie bits (int)	1	0
table_id	Table ID to put the flow in (int)	0	0
idle_timeout	Idle time before discarding (seconds) (int)	30	0
hard_timeout	Max time before discarding (seconds) (int)	30	0
priority	Priority level of flow entry (int)	11111	0
buffer_id	Buffered packet to apply to, or OFP_NO_BUFFER (int)	1	OFP_NO_BUFFER
flags	Bitmap of OFPFF_* flags (int)	1	0
match	Fields to match (dict)	{"in_port":1}	{} #wildcarded
actions	Instruction set (list of dict)	[{"type":"OUTPUT", "port":2}]	[] #DROP

Example of use:

```
$ curl -X POST -d '{
  "dpid": 1,
  "cookie": 1,
  "cookie_mask": 1,
  "table_id": 0,
  "idle_timeout": 30,
  "hard_timeout": 30,
  "priority": 11111,
  "flags": 1,
  "match":{
    "in_port":1
  },
  "actions":[
    {
      "type":"OUTPUT",
      "port": 2
    }
  ]
}' http://localhost:8080/stats/flowentry/modify_strict
```

Delete all matching flow entries

Delete all matching flow entries of the switch.

Usage:

Method	POST
URI	/stats/flowentry/delete

Request message body:

Attribute	Description	Example	Default
dpid	Datapath ID (int)	1	(Mandatory)
cookie	Opaque controller-issued identifier (int)	1	0
cookie_mask	Mask used to restrict the cookie bits (int)	1	0
table_id	Table ID to put the flow in (int)	0	0
idle_timeout	Idle time before discarding (seconds) (int)	30	0
hard_timeout	Max time before discarding (seconds) (int)	30	0
priority	Priority level of flow entry (int)	11111	0
buffer_id	Buffered packet to apply to, or OFPP_NO_BUFFER (int)	1	OFPP_NO_BUFFER
out_port	Output port (int)	1	OFPP_ANY
out_group	Output group (int)	1	OFPG_ANY
flags	Bitmap of OFPF_* flags (int)	1	0
match	Fields to match (dict)	{ "in_port":1 }	{ } #wildcarded
actions	Instruction set (list of dict)	[{"type": "OUTPUT", "port": 2}]	[] #DROP

Example of use:

```
$ curl -X POST -d '{
  "dpid": 1,
  "cookie": 1,
  "cookie_mask": 1,
  "table_id": 0,
  "idle_timeout": 30,
  "hard_timeout": 30,
  "priority": 11111,
  "flags": 1,
  "match": {
    "in_port": 1
  },
  "actions": [
    {
      "type": "OUTPUT",
      "port": 2
    }
  ]
}' http://localhost:8080/stats/flowentry/delete
```

Delete flow entry strictly

Delete flow entry strictly matching wildcards and priority.

Usage:

Method	POST
URI	/stats/flowentry/delete_strict

Request message body:

Attribute	Description	Example	Default
dpid	Datapath ID (int)	1	(Mandatory)
cookie	Opaque controller-issued identifier (int)	1	0
cookie_mask	Mask used to restrict the cookie bits (int)	1	0
table_id	Table ID to put the flow in (int)	0	0
idle_timeout	Idle time before discarding (seconds) (int)	30	0
hard_timeout	Max time before discarding (seconds) (int)	30	0
priority	Priority level of flow entry (int)	11111	0
buffer_id	Buffered packet to apply to, or OFPP_NO_BUFFER (int)	1	OFPP_NO_BUFFER
out_port	Output port (int)	1	OFPP_ANY
out_group	Output group (int)	1	OFPG_ANY
flags	Bitmap of OFPF_* flags (int)	1	0
match	Fields to match (dict)	{ "in_port":1 }	{ } #wildcarded
actions	Instruction set (list of dict)	[{"type":"OUTPUT", "port":2}]	[] #DROP

Example of use:

```
$ curl -X POST -d '{
  "dpid": 1,
  "cookie": 1,
  "cookie_mask": 1,
  "table_id": 0,
  "idle_timeout": 30,
  "hard_timeout": 30,
  "priority": 11111,
  "flags": 1,
  "match":{
    "in_port":1
  },
  "actions":[
    {
      "type":"OUTPUT",
      "port": 2
    }
  ]
}' http://localhost:8080/stats/flowentry/delete_strict
```

Delete all flow entries

Delete all flow entries of the switch which specified with Datapath ID in URI.

Usage:

Method	DELETE
URI	/stats/flowentry/clear/<dpid>

Example of use:

```
$ curl -X DELETE http://localhost:8080/stats/flowentry/clear/1
```

Add a group entry

Add a group entry to the switch.

Usage:

Method	POST
URI	/stats/grouppentry/add

Request message body:

At-tribute	Description	Example	De-fault
dpid	Datapath ID (int)	1	(Manda-tory)
type	One of OFPGT_* (string)	“ALL”	“ALL”
group_id	Group ID (int)	1	0
buckets	struct ofp_bucket		
– weight	Relative weight of bucket (Only defined for select groups)	0	0
– watch_portlive	Port whose state affects whether this bucket is live (Only required for fast failover groups)	4294967295	OFPP_ANY
– watch_grouplive	Group whose state affects whether this bucket is live (Only required for fast failover groups)	4294967295	OFPG_ANY
– actions	0 or more actions associated with the bucket (list of dict)	[{"type": "OUTPUT", "port": 1}]	[] #DROP

Example of use:

```
$ curl -X POST -d '{
  "dpid": 1,
  "type": "ALL",
  "group_id": 1,
  "buckets": [
    {
      "actions": [
        {
          "type": "OUTPUT",
          "port": 1
        }
      ]
    }
  ]
}' http://localhost:8080/stats/grouppentry/add
```

Note: To confirm group entry registration, please see *Get group description stats*.

Modify a group entry

Modify a group entry to the switch.

Usage:

Method	POST
URI	/stats/grouppentry/modify

Request message body:

Attribute	Description	Example	Default
dpid	Datapath ID (int)	1	(Mandatory)
type	One of OFPGT_* (string)	"ALL"	"ALL"
group_id	Group ID (int)	1	0
buckets	struct ofp_bucket		
- weight	Relative weight of bucket (Only defined for select groups)	0	0
- watch_port	Port whose state affects whether this bucket is active (Only required for fast failover groups)	4294967295	OFPP_ANY
- watch_group	Group whose state affects whether this bucket is active (Only required for fast failover groups)	4294967295	OFPG_ANY
- actions	0 or more actions associated with the bucket (list of dict)	[{"type": "OUTPUT", "port": 1}]	[] #DROP

Example of use:

```
$ curl -X POST -d '{
  "dpid": 1,
  "type": "ALL",
  "group_id": 1,
  "buckets": [
    {
      "actions": [
        {
          "type": "OUTPUT",
          "port": 1
        }
      ]
    }
  ]
}' http://localhost:8080/stats/grouppentry/modify
```

Delete a group entry

Delete a group entry to the switch.

Usage:

Method	POST
URI	/stats/grouppentry/delete

Request message body:

Attribute	Description	Example	Default
dpid	Datapath ID (int)	1	(Mandatory)
group_id	Group ID (int)	1	0

Example of use:

```
$ curl -X POST -d '{
  "dpid": 1,
  "group_id": 1
}' http://localhost:8080/stats/grouppentry/delete
```

Modify the behavior of the port

Modify the behavior of the physical port.

Usage:

Method	POST
URI	/stats/portdesc/modify

Request message body:

Attribute	Description	Example	Default
dpid	Datapath ID (int)	1	(Mandatory)
port_no	Port number (int)	1	0
config	Bitmap of OFPPC_* flags (int)	1	0
mask	Bitmap of OFPPC_* flags to be changed (int)	1	0

Example of use:

```
$ curl -X POST -d '{
  "dpid": 1,
  "port_no": 1,
  "config": 1,
  "mask": 1
}' http://localhost:8080/stats/portdesc/modify
```

Note: To confirm port description, please see *Get ports description*.

Add a meter entry

Add a meter entry to the switch.

Usage:

Method	POST
URI	/stats/meterentry/add

Request message body:

Attribute	Description	Example	Default
dpid	Datapath ID (int)	1	(Mandatory)
flags	Bitmap of OFPMF_* flags (list)	["KBPS"]	[] #Empty
meter_id	Meter ID (int)	1	0
bands	struct ofp_meter_band_header		
- type	One of OFPMBT_* (string)	"DROP"	None
- rate	Rate for this band (int)	1000	None
- burst_size	Size of bursts (int)	100	None

Example of use:

```
$ curl -X POST -d '{
  "dpid": 1,
  "flags": "KBPS",
  "meter_id": 1,
  "bands": [
    {
      "type": "DROP",
      "rate": 1000
    }
  ]
}' http://localhost:8080/stats/meterentry/add
```

Note: To confirm meter entry registration, please see *Get meter config stats*.

Modify a meter entry

Modify a meter entry to the switch.

Usage:

Method	POST
URI	/stats/meterentry/modify

Request message body:

Attribute	Description	Example	Default
dpid	Datapath ID (int)	1	(Mandatory)
flags	Bitmap of OFPMF_* flags (list)	["KBPS"]	[] #Empty
meter_id	Meter ID (int)	1	0
bands	struct ofp_meter_band_header		
- type	One of OFPMBT_* (string)	"DROP"	None
- rate	Rate for this band (int)	1000	None
- burst_size	Size of bursts (int)	100	None

Example of use:

```
$ curl -X POST -d '{
  "dpid": 1,
  "meter_id": 1,
  "flags": "KBPS",
  "bands": [
    {
      "type": "DROP",
      "rate": 1000
    }
  ]
}' http://localhost:8080/stats/meterentry/modify
```

Delete a meter entry

Delete a meter entry to the switch.

Usage:

Method	POST
URI	/stats/meterentry/delete

Request message body:

Attribute	Description	Example	Default
dpid	Datapath ID (int)	1	(Mandatory)
meter_id	Meter ID (int)	1	0

Example of use:

```
$ curl -X POST -d '{
  "dpid": 1,
  "meter_id": 1
}' http://localhost:8080/stats/meterentry/delete
```

7.2.3 Support for experimenter multipart

Send a experimenter message

Send a experimenter message to the switch which specified with Datapath ID in URI.

Usage:

Method	POST
URI	/stats/experimenter/<dpid>

Request message body:

Attribute	Description	Example	Default
dpid	Datapath ID (int)	1	(Mandatory)
experimenter	Experimenter ID (int)	1	0
exp_type	Experimenter defined (int)	1	0
data_type	Data format type ("ascii" or "base64")	"ascii"	"ascii"
data	Data to send (string)	"data"	"" #Empty

Example of use:

```
$ curl -X POST -d '{
  "dpid": 1,
  "experimenter": 1,
  "exp_type": 1,
  "data_type": "ascii",
  "data": "data"
}' http://localhost:8080/stats/experimenter/1
```

7.2.4 Reference: Description of Match and Actions

Description of Match on request messages

List of Match fields (OpenFlow1.0):

Match field	Description	Example
in_port	Input switch port (int)	{“in_port”: 7}
dl_src	Ethernet source address (string)	{“dl_src”: “aa:bb:cc:11:22:33”}
dl_dst	Ethernet destination address (string)	{“dl_dst”: “aa:bb:cc:11:22:33”}
dl_vlan	Input VLAN id (int)	{“dl_vlan”: 5}
dl_vlan_pcp	Input VLAN priority (int)	{“dl_vlan_pcp”: 3, “dl_vlan”: 3}
dl_type	Ethernet frame type (int)	{“dl_type”: 123}
nw_tos	IP ToS (int)	{“nw_tos”: 16, “dl_type”: 2048}
nw_proto	IP protocol or lower 8 bits of ARP opcode (int)	{“nw_proto”: 5, “dl_type”: 2048}
nw_src	IPv4 source address (string)	{“nw_src”: “192.168.0.1”, “dl_type”: 2048}
nw_dst	IPv4 destination address (string)	{“nw_dst”: “192.168.0.1/24”, “dl_type”: 2048}
tp_src	TCP/UDP source port (int)	{“tp_src”: 1, “nw_proto”: 6, “dl_type”: 2048}
tp_dst	TCP/UDP destination port (int)	{“tp_dst”: 2, “nw_proto”: 6, “dl_type”: 2048}

Note: IPv4 address field can be described as IP Prefix like as follows.

IPv4 address:

```
"192.168.0.1"
"192.168.0.2/24"
```

List of Match fields (OpenFlow1.2 or later):

Match field	Description	Example
in_port	Switch input port (int)	{“in_port”: 7}
in_phy_port	Switch physical input port (int)	{“in_phy_port”: 5, “in_port”: 3}
metadata	Metadata passed between tables (int or string)	{“metadata”: 12345} {“metadata”: “0x1212/0xffff”}
dl_dst	Ethernet destination address (string)	{“dl_dst”: “aa:bb:cc:11:22:33/00:00:00:00:ff:ff”}
dl_src	Ethernet source address (string)	{“dl_src”: “aa:bb:cc:11:22:33”}
eth_dst	Ethernet destination address (string)	{“eth_dst”: “aa:bb:cc:11:22:33/00:00:00:00:ff:ff”}
eth_src	Ethernet source address (string)	{“eth_src”: “aa:bb:cc:11:22:33”}
dl_type	Ethernet frame type (int)	{“dl_type”: 123}
eth_type	Ethernet frame type (int)	{“eth_type”: 2048}
dl_vlan	VLAN id (int or string)	See <i>Example of VLAN ID match field</i>
vlan_vid	VLAN id (int or string)	See <i>Example of VLAN ID match field</i>
vlan_pcp	VLAN priority (int)	{“vlan_pcp”: 3, “vlan_vid”: 3}

Continued on next page

Table 7.1 – continued from previous page

Match field	Description	Example
ip_dscp	IP DSCP (6 bits in ToS field) (int)	{"ip_dscp": 3, "eth_type": 2048}
ip_ecn	IP ECN (2 bits in ToS field) (int)	{"ip_ecn": 0, "eth_type": 34525}
nw_proto	IP protocol (int)	{"nw_proto": 5, "eth_type": 2048}
ip_proto	IP protocol (int)	{"ip_proto": 5, "eth_type": 34525}
tp_src	Transport layer source port (int)	{"tp_src": 1, "ip_proto": 6, "eth_type": 2048}
tp_dst	Transport layer destination port (int)	{"tp_dst": 2, "ip_proto": 6, "eth_type": 2048}
nw_src	IPv4 source address (string)	{"nw_src": "192.168.0.1", "eth_type": 2048}
nw_dst	IPv4 destination address (string)	{"nw_dst": "192.168.0.1/24", "eth_type": 2048}
ipv4_src	IPv4 source address (string)	{"ipv4_src": "192.168.0.1", "eth_type": 2048}
ipv4_dst	IPv4 destination address (string)	{"ipv4_dst": "192.168.10.10/255.255.255.0", "eth_type": 2048}
tcp_src	TCP source port (int)	{"tcp_src": 3, "ip_proto": 6, "eth_type": 2048}
tcp_dst	TCP destination port (int)	{"tcp_dst": 5, "ip_proto": 6, "eth_type": 2048}
udp_src	UDP source port (int)	{"udp_src": 2, "ip_proto": 17, "eth_type": 2048}
udp_dst	UDP destination port (int)	{"udp_dst": 6, "ip_proto": 17, "eth_type": 2048}
sctp_src	SCTP source port (int)	{"sctp_src": 99, "ip_proto": 132, "eth_type": 2048}
sctp_dst	SCTP destination port (int)	{"sctp_dst": 99, "ip_proto": 132, "eth_type": 2048}
icmpv4_type	ICMP type (int)	{"icmpv4_type": 5, "ip_proto": 1, "eth_type": 2048}
icmpv4_code	ICMP code (int)	{"icmpv4_code": 6, "ip_proto": 1, "eth_type": 2048}
arp_op	ARP opcode (int)	{"arp_op": 3, "eth_type": 2054}
arp_spa	ARP source IPv4 address (string)	{"arp_spa": "192.168.0.11", "eth_type": 2054}
arp_tpa	ARP target IPv4 address (string)	{"arp_tpa": "192.168.0.44/24", "eth_type": 2054}
arp_sha	ARP source hardware address (string)	{"arp_sha": "aa:bb:cc:11:22:33", "eth_type": 2054}

Continued on next page

Table 7.1 – continued from previous page

Match field	Description	Example
arp_tha	ARP target hardware address (string)	{“arp_tha”: “aa:bb:cc:11:22:33/00:00:00:00:ff:ff”, “eth_type”: 2054}
ipv6_src	IPv6 source address (string)	{“ipv6_src”: “2001::aaaa:bbbb:cccc:1111”, “eth_type”: 34525}
ipv6_dst	IPv6 destination address (string)	{“ipv6_dst”: “2001::ffff:cccc:bbbb:1111/64”, “eth_type”: 34525}
ipv6_flabel	IPv6 Flow Label (int)	{“ipv6_flabel”: 2, “eth_type”: 34525}
icmpv6_type	ICMPv6 type (int)	{“icmpv6_type”: 3, “ip_proto”: 58, “eth_type”: 34525}
icmpv6_code	ICMPv6 code (int)	{“icmpv6_code”: 4, “ip_proto”: 58, “eth_type”: 34525}
ipv6_nd_target	Target address for Neighbor Discovery (string)	{“ipv6_nd_target”: “2001::ffff:cccc:bbbb:1111”, “icmpv6_type”: 135, “ip_proto”: 58, “eth_type”: 34525}
ipv6_nd_sll	Source link-layer for Neighbor Discovery (string)	{“ipv6_nd_sll”: “aa:bb:cc:11:22:33”, “icmpv6_type”: 135, “ip_proto”: 58, “eth_type”: 34525}
ipv6_nd_tll	Target link-layer for Neighbor Discovery (string)	{“ipv6_nd_tll”: “aa:bb:cc:11:22:33”, “icmpv6_type”: 136, “ip_proto”: 58, “eth_type”: 34525}
mpls_label	MPLS label (int)	{“mpls_label”: 3, “eth_type”: 34888}
mpls_tc	MPLS Traffic Class (int)	{“mpls_tc”: 2, “eth_type”: 34888}
mpls_bos	MPLS BoS bit (int)	{“mpls_bos”: 1, “eth_type”: 34888}
pbb_isid	PBB I-SID (int or string)	{“pbb_isid”: 5, “eth_type”: 35047} {“pbb_isid”: “0x05/0xff”, “eth_type”: 35047}
tunnel_id	Logical Port Metadata (int or string)	{“tunnel_id”: 7} {“tunnel_id”: “0x07/0xff”}
Continued on next page		

Note: When “dl_vlan” field is described as decimal int value, OFPVID_PRESENT(0x1000) bit is automatically applied.

The following is available in OpenFlow1.2 or later.

- To match only packets without a VLAN tag:

```
$ curl -X POST -d '{
  "dpid": 1,
  "match":{
    "dl_vlan": "0x0000" # Describe OFPVID_NONE(0x0000)
  },
  "actions":[
    {
      "type":"OUTPUT",
      "port": 1
    }
  ]
}' http://localhost:8080/stats/flowentry/add
```

- To match only packets with a VLAN tag regardless of its value:

```
$ curl -X POST -d '{
  "dpid": 1,
  "match":{
    "dl_vlan": "0x1000/0x1000" # Describe OFPVID_PRESENT(0x1000/0x1000)
  },
  "actions":[
    {
      "type":"OUTPUT",
      "port": 1
    }
  ]
}' http://localhost:8080/stats/flowentry/add
```

- To match only packets with VLAN tag and VLAN ID equal value 5:

```
$ curl -X POST -d '{
  "dpid": 1,
  "match":{
    "dl_vlan": "0x1005" # Describe sum of VLAN-ID(e.g. 5) | OFPVID_PRESENT(0x1000)
  },
  "actions":[
    {
      "type":"OUTPUT",
      "port": 1
    }
  ]
}' http://localhost:8080/stats/flowentry/add
```

Note: When using the descriptions for OpenFlow1.2 or later, please describe “dl_vlan” field as hexadecimal string value, and OFPVID_PRESENT(0x1000) bit is NOT automatically applied.

Description of Actions on request messages

List of Actions (OpenFlow1.0):

Actions	Description	Example
OUTPUT	Output packet from “port”	{“type”: “OUTPUT”, “port”: 3}
SET_VLAN_VID	Set the 802.1Q VLAN ID using “vlan_vid”	{“type”: “SET_VLAN_VID”, “vlan_vid”: 5}
SET_VLAN_PCP	Set the 802.1Q priority using “vlan_pcp”	{“type”: “SET_VLAN_PCP”, “vlan_pcp”: 3}
STRIP_VLAN	Strip the 802.1Q header	{“type”: “STRIP_VLAN”}
SET_DL_SRC	Set ethernet source address using “dl_src”	{“type”: “SET_DL_SRC”, “dl_src”: “aa:bb:cc:11:22:33”}
SET_DL_DST	Set ethernet destination address using “dl_dst”	{“type”: “SET_DL_DST”, “dl_dst”: “aa:bb:cc:11:22:33”}
SET_NW_SRC	Set IP source address using “nw_src”	{“type”: “SET_NW_SRC”, “nw_src”: “10.0.0.1”}
SET_NW_DST	Set IP destination address using “nw_dst”	{“type”: “SET_NW_DST”, “nw_dst”: “10.0.0.1”}
SET_NW_TOS	Set IP ToS (DSCP field, 6 bits) using “nw_tos”	{“type”: “SET_NW_TOS”, “nw_tos”: 184}
SET_TP_SRC	Set TCP/UDP source port using “tp_src”	{“type”: “SET_TP_SRC”, “tp_src”: 8080}
SET_TP_DST	Set TCP/UDP destination port using “tp_dst”	{“type”: “SET_TP_DST”, “tp_dst”: 8080}
ENQUEUE	Output to queue with “queue_id” attached to “port”	{“type”: “ENQUEUE”, “queue_id”: 3, “port”: 1}

List of Actions (OpenFlow1.2 or later):

Actions	Description	Example
OUT-PUT	Output packet from “port”	{“type”: “OUTPUT”, “port”: 3}
COPY_TTL_OUT	Copy TTL outwards	{“type”: “COPY_TTL_OUT”}
COPY_TTL_IN	Copy TTL inwards	{“type”: “COPY_TTL_IN”}
SET_MPLS_TTL	Set MPLS TTL using “mpls_ttl”	{“type”: “SET_MPLS_TTL”, “mpls_ttl”: 64}
DEC_MPLS_TTL	Decrement MPLS TTL	{“type”: “DEC_MPLS_TTL”}
PUSH_VLAN	Push a new VLAN tag with “ethertype”	{“type”: “PUSH_VLAN”, “ethertype”: 33024}
POP_VLAN	Pop the outer VLAN tag	{“type”: “POP_VLAN”}
PUSH_MPLS	Push a new MPLS tag with “ethertype”	{“type”: “PUSH_MPLS”, “ethertype”: 34887}
POP_MPLS	Pop the outer MPLS tag with “ethertype”	{“type”: “POP_MPLS”, “ethertype”: 2054}
SET_QUEUE	Set queue id using “queue_id” when outputting to a port	{“type”: “SET_QUEUE”, “queue_id”: 7}
GROUP	Apply group identified by “group_id”	{“type”: “GROUP”, “group_id”: 5}
SET_NW_TTL	Set IP TTL using “nw_ttl”	{“type”: “SET_NW_TTL”, “nw_ttl”: 64}
DEC_NW_TTL	Decrement IP TTL	{“type”: “DEC_NW_TTL”}
SET_FIELD	Set a “field” using “value” (The set of keywords available for “field” is the same as match field)	See <i>Example of set-field action</i>
PUSH_PBB	Push a new PBB service tag with “ethertype”	{“type”: “PUSH_PBB”, “ethertype”: 35047}
POP_PBB	Pop the outer PBB service tag	{“type”: “POP_PBB”}
EX-PERIMENTER	Extensible action for the experimenter (Set “base64” or “ascii” to “data_type” field)	{“type”: “EXPERIMENTER”, “experimenter”: 101, “data”: “AAECAwQFBgc=”, “data_type”: “base64”}
GOTO_TABLE	(Instruction) Setup the next table identified by “table_id”	{“type”: “GOTO_TABLE”, “table_id”: 8}
WRITE_METADATA	(Instruction) Setup the metadata field using “metadata” and “metadata_mask”	{“type”: “WRITE_METADATA”, “metadata”: 0x3, “metadata_mask”: 0x3}
METER	(Instruction) Apply meter identified by “meter_id”	{“type”: “METER”, “meter_id”: 3}
WRITE_ACTIONS	(Instruction) Write the action(s) onto the datapath action set	{“type”: “WRITE_ACTIONS”, “actions”: [{“type”: “POP_VLAN”, “ethertype”: 33024}, {“type”: “OUTPUT”, “port”: 2}]}
CLEAR_ACTIONS	(Instruction) Clears all actions from the datapath action set	{“type”: “CLEAR_ACTIONS”}

Example of set-field action

To set VLAN ID to non-VLAN-tagged frame:

```

"actions": [
  {
    "type": "PUSH_VLAN",      # Push a new VLAN tag if a input frame is non-VLAN-tagged
    "ethertype": 33024      # Ethertype 0x8100(=33024): IEEE 802.1Q VLAN-tagged frame
  }
]

```

```
    },
    {
        "type": "SET_FIELD",
        "field": "vlan_vid",      # Set VLAN ID
        "value": 4102            # Describe sum of vlan_id(e.g. 6) | OFPVID_PRESENT(0x1000=4096)
    },
    {
        "type": "OUTPUT",
        "port": 2
    }
]
```

Indices and tables

- `genindex`
- `modindex`
- `search`

r

- ryu.app.cbench, 9
- ryu.app.ofctl.api, 399
- ryu.app.ofctl.exception, 400
- ryu.app.simple_switch, 9
- ryu.base.app_manager, 7
- ryu.controller.controller, 7
- ryu.controller.dpset, 7
- ryu.controller.ofp_event, 7
- ryu.controller.ofp_handler, 7
- ryu.lib.netconf, 9
- ryu.lib.of_config, 9
- ryu.lib.ovs, 9
- ryu.lib.packet, 9
- ryu.lib.packet.arp, 19
- ryu.lib.packet.cfm, 26
- ryu.lib.packet.ethernet, 18
- ryu.lib.packet.icmp, 20
- ryu.lib.packet.icmpv6, 23
- ryu.lib.packet.ipv4, 19
- ryu.lib.packet.ipv6, 21
- ryu.lib.packet.mpls, 19
- ryu.lib.packet.packet, 16
- ryu.lib.packet.packet_base, 17
- ryu.lib.packet.pbb, 19
- ryu.lib.packet.sctp, 42
- ryu.lib.packet.stream_parser, 17
- ryu.lib.packet.tcp, 31
- ryu.lib.packet.udp, 31
- ryu.lib.packet.vlan, 18
- ryu.lib.xflow, 9
- ryu.ofproto.nx_match, 377
- ryu.ofproto.ofproto_v1_0, 7
- ryu.ofproto.ofproto_v1_0_parser, 7
- ryu.ofproto.ofproto_v1_2, 7
- ryu.ofproto.ofproto_v1_2_parser, 8
- ryu.ofproto.ofproto_v1_3, 8
- ryu.ofproto.ofproto_v1_3_parser, 8
- ryu.ofproto.ofproto_v1_4, 8
- ryu.ofproto.ofproto_v1_4_parser, 8
- ryu.ofproto.ofproto_v1_5, 8
- ryu.ofproto.ofproto_v1_5_parser, 8
- ryu.topology, 9

Symbols

- `_CONTEXTS` (ryu.base.app_manager.RyuApp attribute), 378
 - `_EVENTS` (ryu.base.app_manager.RyuApp attribute), 378
 - `_TYPE` (ryu.ofproto.ofproto_parser.MsgBase attribute), 62
- ### A
- `add_protocol()` (ryu.lib.packet.packet.Packet method), 16
 - `arp` (class in ryu.lib.packet.arp), 19
 - `arp_ip()` (in module ryu.lib.packet.arp), 19
 - `ASPathFilter` (class in ryu.services.protocols.bgp.info_base.base), 59
 - `attribute_map_get()` (ryu.services.protocols.bgp.bgpspeaker.BGPSpeaker method), 55
 - `attribute_map_set()` (ryu.services.protocols.bgp.bgpspeaker.BGPSpeaker method), 56
 - `AttributeMap` (class in ryu.services.protocols.bgp.info_base.base), 60
 - `auth` (class in ryu.lib.packet.ipv6), 21
 - `authenticate()` (ryu.lib.packet.bfd.bfd method), 51
 - `authenticate()` (ryu.lib.packet.bfd.KeyedMD5 method), 52
 - `authenticate()` (ryu.lib.packet.bfd.KeyedSHA1 method), 53
 - `authenticate()` (ryu.lib.packet.bfd.SimplePassword method), 51
- ### B
- `bfd` (class in ryu.lib.packet.bfd), 50
 - `BGPKeepAlive` (class in ryu.lib.packet.bgp), 41
 - `BGPMessage` (class in ryu.lib.packet.bgp), 40
 - `BGPNotification` (class in ryu.lib.packet.bgp), 41
 - `BGPOpen` (class in ryu.lib.packet.bgp), 40
 - `BGPSpeaker` (class in ryu.services.protocols.bgp.bgpspeaker), 55
 - `BGPUUpdate` (class in ryu.lib.packet.bgp), 41
 - `bmp_server_add()` (ryu.services.protocols.bgp.bgpspeaker.BGPSpeaker method), 56
 - `bmp_server_del()` (ryu.services.protocols.bgp.bgpspeaker.BGPSpeaker method), 56
 - `bpdu` (class in ryu.lib.packet.bpdu), 37
- ### C
- `cause_cookie_while_shutdown` (class in ryu.lib.packet.sctp), 42
 - `cause_invalid_param` (class in ryu.lib.packet.sctp), 42
 - `cause_invalid_stream_id` (class in ryu.lib.packet.sctp), 42
 - `cause_missing_param` (class in ryu.lib.packet.sctp), 42
 - `cause_no_userdata` (class in ryu.lib.packet.sctp), 42
 - `cause_out_of_resource` (class in ryu.lib.packet.sctp), 43
 - `cause_protocol_violation` (class in ryu.lib.packet.sctp), 43
 - `cause_restart_with_new_addr` (class in ryu.lib.packet.sctp), 43
 - `cause_stale_cookie` (class in ryu.lib.packet.sctp), 43
 - `cause_unrecognized_chunk` (class in ryu.lib.packet.sctp), 44
 - `cause_unrecognized_param` (class in ryu.lib.packet.sctp), 44
 - `cause_unresolvable_addr` (class in ryu.lib.packet.sctp), 44
 - `cause_user_initiated_abort` (class in ryu.lib.packet.sctp), 44
 - `cc_message` (class in ryu.lib.packet.cfm), 26
 - `cfm` (class in ryu.lib.packet.cfm), 27
 - `chunk_abort` (class in ryu.lib.packet.sctp), 44
 - `chunk_cookie_ack` (class in ryu.lib.packet.sctp), 44
 - `chunk_cookie_echo` (class in ryu.lib.packet.sctp), 45
 - `chunk_cwr` (class in ryu.lib.packet.sctp), 45
 - `chunk_data` (class in ryu.lib.packet.sctp), 45
 - `chunk_ecn_echo` (class in ryu.lib.packet.sctp), 45
 - `chunk_error` (class in ryu.lib.packet.sctp), 46
 - `chunk_heartbeat` (class in ryu.lib.packet.sctp), 46
 - `chunk_heartbeat_ack` (class in ryu.lib.packet.sctp), 46
 - `chunk_init` (class in ryu.lib.packet.sctp), 46
 - `chunk_init_ack` (class in ryu.lib.packet.sctp), 47
 - `chunk_sack` (class in ryu.lib.packet.sctp), 47
 - `chunk_shutdown` (class in ryu.lib.packet.sctp), 47
 - `chunk_shutdown_ack` (class in ryu.lib.packet.sctp), 48
 - `chunk_shutdown_complete` (class in ryu.lib.packet.sctp), 48

- clone() (ryu.services.protocols.bgp.info_base.base.ASPathFilter method), 60
 - clone() (ryu.services.protocols.bgp.info_base.base.AttributeMap method), 60
 - clone() (ryu.services.protocols.bgp.info_base.base.PrefixFilter method), 59
 - close() (ryu.base.app_manager.RyuApp method), 378
 - ConfigurationBPDUs (class in ryu.lib.packet.bpdu), 37
 - context_iteritems() (ryu.base.app_manager.RyuApp class method), 378
 - ControlFormatI (class in ryu.lib.packet.llc), 37
 - ControlFormatS (class in ryu.lib.packet.llc), 37
 - ControlFormatU (class in ryu.lib.packet.llc), 37
 - create() (ryu.lib.packet.vrrp.vrrpv2 static method), 33
 - create() (ryu.lib.packet.vrrp.vrrpv3 static method), 33
 - create_packet() (ryu.lib.packet.vrrp.vrrp method), 33
- ## D
- data_tlv (class in ryu.lib.packet.cfm), 27
 - dest_unreach (class in ryu.lib.packet.icmp), 20
 - dhcp (class in ryu.lib.packet.dhcp), 31
 - DPSets (class in ryu.controller.dpset), 379
 - dst_opts (class in ryu.lib.packet.ipv6), 21
- ## E
- echo (class in ryu.lib.packet.icmp), 20
 - echo (class in ryu.lib.packet.icmpv6), 23
 - ethernet (class in ryu.lib.packet.ethernet), 18
 - evaluate() (ryu.services.protocols.bgp.info_base.base.ASPathFilter method), 60
 - evaluate() (ryu.services.protocols.bgp.info_base.base.AttributeMap method), 60
 - evaluate() (ryu.services.protocols.bgp.info_base.base.PrefixFilter method), 59
 - EventPrefix (class in ryu.services.protocols.bgp.bgpspeaker), 59
- ## F
- fragment (class in ryu.lib.packet.ipv6), 21
 - from_jsondict() (ryu.ofproto.ofproto_parser.MsgBase method), 62
- ## G
- get() (ryu.controller.dpset.DPSets method), 379
 - get_all() (ryu.controller.dpset.DPSets method), 379
 - get_datapath() (in module ryu.app.ofctl.api), 399
 - get_packet_type() (ryu.lib.packet.ethernet.ethernet class method), 18
 - get_packet_type() (ryu.lib.packet.packet_base.PacketBase class method), 17
 - get_packet_type() (ryu.lib.packet.vlan.vlan class method), 18
 - get_port() (ryu.controller.dpset.DPSets method), 379
 - get_ports() (ryu.controller.dpset.DPSets method), 379
- get_protocol() (ryu.lib.packet.packet.Packet method), 16
 - get_protocols() (ryu.lib.packet.packet.Packet method), 16
- ## H
- Header (class in ryu.lib.packet.ipv6), 22
 - hop_opts (class in ryu.lib.packet.ipv6), 22
- ## I
- icmp (class in ryu.lib.packet.icmp), 21
 - icmpv6 (class in ryu.lib.packet.icmpv6), 23
 - igmp (class in ryu.lib.packet.igmp), 39
 - igmpv3_query (class in ryu.lib.packet.igmp), 39
 - igmpv3_report (class in ryu.lib.packet.igmp), 40
 - igmpv3_report_group (class in ryu.lib.packet.igmp), 40
 - in_filter_get() (ryu.services.protocols.bgp.bgpspeaker.BGPSpeaker method), 56
 - in_filter_set() (ryu.services.protocols.bgp.bgpspeaker.BGPSpeaker method), 56
 - interface_status_tlv (class in ryu.lib.packet.cfm), 27
 - InvalidDatapath, 400
 - ipv4 (class in ryu.lib.packet.ipv4), 19
 - ipv6 (class in ryu.lib.packet.ipv6), 22
 - itag (class in ryu.lib.packet.pbb), 19
- ## K
- KeyedMD5 (class in ryu.lib.packet.bfd), 52
 - KeyedSHA1 (class in ryu.lib.packet.bfd), 53
- ## L
- lacc (class in ryu.lib.packet.slow), 34
 - link_trace_message (class in ryu.lib.packet.cfm), 28
 - link_trace_reply (class in ryu.lib.packet.cfm), 28
 - llc (class in ryu.lib.packet.llc), 36
 - loopback_message (class in ryu.lib.packet.cfm), 28
 - loopback_reply (class in ryu.lib.packet.cfm), 29
 - ltm_egress_identifier_tlv (class in ryu.lib.packet.cfm), 29
 - ltr_egress_identifier_tlv (class in ryu.lib.packet.cfm), 29
- ## M
- MeticulousKeyedMD5 (class in ryu.lib.packet.bfd), 52
 - MeticulousKeyedSHA1 (class in ryu.lib.packet.bfd), 53
 - mld (class in ryu.lib.packet.icmpv6), 24
 - mldv2_query (class in ryu.lib.packet.icmpv6), 24
 - mldv2_report (class in ryu.lib.packet.icmpv6), 24
 - mldv2_report_group (class in ryu.lib.packet.icmpv6), 24
 - mpls (class in ryu.lib.packet.mpls), 19
 - MsgBase (class in ryu.ofproto.ofproto_parser), 62
- ## N
- nd_neighbor (class in ryu.lib.packet.icmpv6), 25
 - nd_option_pi (class in ryu.lib.packet.icmpv6), 25
 - nd_option_sla (class in ryu.lib.packet.icmpv6), 25
 - nd_option_tla (class in ryu.lib.packet.icmpv6), 26

nd_router_advert (class in ryu.lib.packet.icmpv6), 26		OFPAActionCopyTtlOut (class in ryu.ofproto.ofproto_v1_4_parser), 283	
nd_router_solicit (class in ryu.lib.packet.icmpv6), 26		OFPAActionCopyTtlOut (class in ryu.ofproto.ofproto_v1_5_parser), 373	
neighbor_add() (ryu.services.protocols.bgp.bgpspeaker.BGPPeerAction method), 56		OFPAActionDecMplsTtl (class in ryu.ofproto.ofproto_v1_2_parser), 129	
neighbor_del() (ryu.services.protocols.bgp.bgpspeaker.BGPPeerAction method), 57		OFPAActionDecMplsTtl (class in ryu.ofproto.ofproto_v1_3_parser), 190	
neighbor_get() (ryu.services.protocols.bgp.bgpspeaker.BGPPeerAction method), 57		OFPAActionDecMplsTtl (class in ryu.ofproto.ofproto_v1_4_parser), 283	
neighbor_reset() (ryu.services.protocols.bgp.bgpspeaker.BGPPeerAction method), 57		OFPAActionDecMplsTtl (class in ryu.ofproto.ofproto_v1_5_parser), 374	
neighbor_state_get() (ryu.services.protocols.bgp.bgpspeaker.BGPPeerAction method), 57		OFPAActionDecNwTtl (class in ryu.ofproto.ofproto_v1_2_parser), 129	
neighbor_update() (ryu.services.protocols.bgp.bgpspeaker.BGPPeerAction method), 57		OFPAActionDecNwTtl (class in ryu.ofproto.ofproto_v1_3_parser), 190	
NXActionConjunction (class in ryu.ofproto.ofproto_v1_3_parser), 377		OFPAActionDecNwTtl (class in ryu.ofproto.ofproto_v1_4_parser), 284	
NXActionCT (class in ryu.ofproto.ofproto_v1_3_parser), 377		OFPAActionDecNwTtl (class in ryu.ofproto.ofproto_v1_5_parser), 374	
NXActionLearn (class in ryu.ofproto.ofproto_v1_3_parser), 377		OFPAActionDIAddr (class in ryu.ofproto.ofproto_v1_0_parser), 84	
NXActionRegMove (class in ryu.ofproto.ofproto_v1_3_parser), 376		OFPAActionEnqueue (class in ryu.ofproto.ofproto_v1_0_parser), 85	
NXActionResubmitTable (class in ryu.ofproto.ofproto_v1_3_parser), 377		OFPAActionExperimenter (class in ryu.ofproto.ofproto_v1_2_parser), 130	
NXFlowSpecLoad (class in ryu.ofproto.ofproto_v1_3_parser), 377		OFPAActionExperimenter (class in ryu.ofproto.ofproto_v1_3_parser), 191	
NXFlowSpecMatch (class in ryu.ofproto.ofproto_v1_3_parser), 377		OFPAActionExperimenter (class in ryu.ofproto.ofproto_v1_4_parser), 284	
NXFlowSpecOutput (class in ryu.ofproto.ofproto_v1_3_parser), 377		OFPAActionExperimenter (class in ryu.ofproto.ofproto_v1_5_parser), 375	
O		OFPAActionGroup (class in ryu.ofproto.ofproto_v1_2_parser), 128	
OSError, 400		OFPAActionGroup (class in ryu.ofproto.ofproto_v1_3_parser), 189	
ofp_msg_from_jsondict() (in module ryu.ofproto.ofproto_parser), 63		OFPAActionGroup (class in ryu.ofproto.ofproto_v1_4_parser), 284	
OFP_VERSIONS (ryu.base.app_manager.RyuApp attribute), 378		OFPAActionGroup (class in ryu.ofproto.ofproto_v1_5_parser), 374	
OFPAAction (class in ryu.ofproto.ofproto_v1_0_parser), 83		OFPAActionHeader (class in ryu.ofproto.ofproto_v1_0_parser), 83	
OFPAActionCopyField (class in ryu.ofproto.ofproto_v1_5_parser), 375		OFPAActionMeter (class in ryu.ofproto.ofproto_v1_5_parser), 375	
OFPAActionCopyTtlIn (class in ryu.ofproto.ofproto_v1_2_parser), 129		OFPAActionNwAddr (class in ryu.ofproto.ofproto_v1_0_parser), 84	
OFPAActionCopyTtlIn (class in ryu.ofproto.ofproto_v1_3_parser), 190		OFPAActionOutput (class in ryu.ofproto.ofproto_v1_0_parser), 83	
OFPAActionCopyTtlIn (class in ryu.ofproto.ofproto_v1_4_parser), 283		OFPAActionOutput (class in ryu.ofproto.ofproto_v1_2_parser), 128	
OFPAActionCopyTtlIn (class in ryu.ofproto.ofproto_v1_5_parser), 373		OFPAActionOutput (class in ryu.ofproto.ofproto_v1_3_parser), 189	
OFPAActionCopyTtlOut (class in ryu.ofproto.ofproto_v1_2_parser), 129		OFPAActionOutput (class in ryu.ofproto.ofproto_v1_4_parser), 283	
OFPAActionCopyTtlOut (class in ryu.ofproto.ofproto_v1_3_parser), 190			

OFPACTIONOutput	(class ryu.ofproto.ofproto_v1_5_parser), 373	in	OFPACTIONSetMplsTtl	(class ryu.ofproto.ofproto_v1_2_parser), 129	in
OFPACTIONPopMpls	(class ryu.ofproto.ofproto_v1_2_parser), 130	in	OFPACTIONSetMplsTtl	(class ryu.ofproto.ofproto_v1_3_parser), 190	in
OFPACTIONPopMpls	(class ryu.ofproto.ofproto_v1_3_parser), 191	in	OFPACTIONSetMplsTtl	(class ryu.ofproto.ofproto_v1_4_parser), 283	in
OFPACTIONPopMpls	(class ryu.ofproto.ofproto_v1_4_parser), 284	in	OFPACTIONSetMplsTtl	(class ryu.ofproto.ofproto_v1_5_parser), 373	in
OFPACTIONPopMpls	(class ryu.ofproto.ofproto_v1_5_parser), 374	in	OFPACTIONSetNwDst	(class ryu.ofproto.ofproto_v1_0_parser), 84	in
OFPACTIONPopPbb	(class ryu.ofproto.ofproto_v1_4_parser), 284	in	OFPACTIONSetNwSrc	(class ryu.ofproto.ofproto_v1_0_parser), 84	in
OFPACTIONPopPbb	(class ryu.ofproto.ofproto_v1_5_parser), 375	in	OFPACTIONSetNwTos	(class ryu.ofproto.ofproto_v1_0_parser), 84	in
OFPACTIONPopVlan	(class ryu.ofproto.ofproto_v1_2_parser), 130	in	OFPACTIONSetNwTtl	(class ryu.ofproto.ofproto_v1_2_parser), 129	in
OFPACTIONPopVlan	(class ryu.ofproto.ofproto_v1_3_parser), 190	in	OFPACTIONSetNwTtl	(class ryu.ofproto.ofproto_v1_3_parser), 190	in
OFPACTIONPopVlan	(class ryu.ofproto.ofproto_v1_4_parser), 283	in	OFPACTIONSetNwTtl	(class ryu.ofproto.ofproto_v1_4_parser), 284	in
OFPACTIONPopVlan	(class ryu.ofproto.ofproto_v1_5_parser), 374	in	OFPACTIONSetNwTtl	(class ryu.ofproto.ofproto_v1_5_parser), 374	in
OFPACTIONPushMpls	(class ryu.ofproto.ofproto_v1_2_parser), 129	in	OFPACTIONSetQueue	(class ryu.ofproto.ofproto_v1_2_parser), 129	in
OFPACTIONPushMpls	(class ryu.ofproto.ofproto_v1_3_parser), 190	in	OFPACTIONSetQueue	(class ryu.ofproto.ofproto_v1_3_parser), 189	in
OFPACTIONPushMpls	(class ryu.ofproto.ofproto_v1_4_parser), 283	in	OFPACTIONSetQueue	(class ryu.ofproto.ofproto_v1_4_parser), 284	in
OFPACTIONPushMpls	(class ryu.ofproto.ofproto_v1_5_parser), 374	in	OFPACTIONSetQueue	(class ryu.ofproto.ofproto_v1_5_parser), 374	in
OFPACTIONPushPbb	(class ryu.ofproto.ofproto_v1_4_parser), 284	in	OFPACTIONSetTpDst	(class ryu.ofproto.ofproto_v1_0_parser), 85	in
OFPACTIONPushPbb	(class ryu.ofproto.ofproto_v1_5_parser), 375	in	OFPACTIONSetTpSrc	(class ryu.ofproto.ofproto_v1_0_parser), 85	in
OFPACTIONPushVlan	(class ryu.ofproto.ofproto_v1_2_parser), 129	in	OFPACTIONStripVlan	(class ryu.ofproto.ofproto_v1_0_parser), 84	in
OFPACTIONPushVlan	(class ryu.ofproto.ofproto_v1_3_parser), 190	in	OFPACTIONTpPort	(class ryu.ofproto.ofproto_v1_0_parser), 85	in
OFPACTIONPushVlan	(class ryu.ofproto.ofproto_v1_4_parser), 283	in	OFPACTIONVendor	(class ryu.ofproto.ofproto_v1_0_parser), 85	in
OFPACTIONPushVlan	(class ryu.ofproto.ofproto_v1_5_parser), 374	in	OFPACTIONVlanPcp	(class ryu.ofproto.ofproto_v1_0_parser), 84	in
OFPACTIONSetDIDst	(class ryu.ofproto.ofproto_v1_0_parser), 84	in	OFPACTIONVlanVid	(class ryu.ofproto.ofproto_v1_0_parser), 84	in
OFPACTIONSetDISrc	(class ryu.ofproto.ofproto_v1_0_parser), 84	in	OFPAggregateStatsReply	(class ryu.ofproto.ofproto_v1_0_parser), 73	in
OFPACTIONSetField	(class ryu.ofproto.ofproto_v1_2_parser), 130	in	OFPAggregateStatsReply	(class ryu.ofproto.ofproto_v1_2_parser), 102	in
OFPACTIONSetField	(class ryu.ofproto.ofproto_v1_3_parser), 191	in	OFPAggregateStatsReply	(class ryu.ofproto.ofproto_v1_3_parser), 153	in
OFPACTIONSetField	(class ryu.ofproto.ofproto_v1_4_parser), 284	in	OFPAggregateStatsReply	(class ryu.ofproto.ofproto_v1_4_parser), 221	in
OFPACTIONSetField	(class ryu.ofproto.ofproto_v1_5_parser), 375	in	OFPAggregateStatsReply	(class ryu.ofproto.ofproto_v1_5_parser), 307	in

OFPAggregateStatsRequest	(class ryu.ofproto.ofproto_v1_0_parser), 72	in	OFPDescStatsReply	(class ryu.ofproto.ofproto_v1_3_parser), 144	in
OFPAggregateStatsRequest	(class ryu.ofproto.ofproto_v1_2_parser), 101	in	OFPDescStatsReply	(class ryu.ofproto.ofproto_v1_4_parser), 212	in
OFPAggregateStatsRequest	(class ryu.ofproto.ofproto_v1_3_parser), 152	in	OFPDescStatsReply	(class ryu.ofproto.ofproto_v1_5_parser), 301	in
OFPAggregateStatsRequest	(class ryu.ofproto.ofproto_v1_4_parser), 220	in	OFPDescStatsRequest	(class ryu.ofproto.ofproto_v1_0_parser), 70	in
OFPAggregateStatsRequest	(class ryu.ofproto.ofproto_v1_5_parser), 307	in	OFPDescStatsRequest	(class ryu.ofproto.ofproto_v1_2_parser), 96	in
OFPBarrierReply	(class ryu.ofproto.ofproto_v1_0_parser), 77	in	OFPDescStatsRequest	(class ryu.ofproto.ofproto_v1_3_parser), 144	in
OFPBarrierReply	(class ryu.ofproto.ofproto_v1_2_parser), 115	in	OFPDescStatsRequest	(class ryu.ofproto.ofproto_v1_4_parser), 212	in
OFPBarrierReply	(class ryu.ofproto.ofproto_v1_3_parser), 172	in	OFPDescStatsRequest	(class ryu.ofproto.ofproto_v1_5_parser), 301	in
OFPBarrierReply	(class ryu.ofproto.ofproto_v1_4_parser), 250	in	OFPEchoReply	(class ryu.ofproto.ofproto_v1_0_parser), 81	in
OFPBarrierReply	(class ryu.ofproto.ofproto_v1_5_parser), 341	in	OFPEchoReply	(class ryu.ofproto.ofproto_v1_2_parser), 124	in
OFPBarrierRequest	(class ryu.ofproto.ofproto_v1_0_parser), 77	in	OFPEchoReply	(class ryu.ofproto.ofproto_v1_3_parser), 185	in
OFPBarrierRequest	(class ryu.ofproto.ofproto_v1_2_parser), 115	in	OFPEchoReply	(class ryu.ofproto.ofproto_v1_4_parser), 277	in
OFPBarrierRequest	(class ryu.ofproto.ofproto_v1_3_parser), 171	in	OFPEchoReply	(class ryu.ofproto.ofproto_v1_5_parser), 367	in
OFPBarrierRequest	(class ryu.ofproto.ofproto_v1_4_parser), 249	in	OFPEchoRequest	(class ryu.ofproto.ofproto_v1_0_parser), 81	in
OFPBarrierRequest	(class ryu.ofproto.ofproto_v1_5_parser), 341	in	OFPEchoRequest	(class ryu.ofproto.ofproto_v1_2_parser), 123	in
OFPBundleAddMsg	(class ryu.ofproto.ofproto_v1_4_parser), 253	in	OFPEchoRequest	(class ryu.ofproto.ofproto_v1_3_parser), 184	in
OFPBundleAddMsg	(class ryu.ofproto.ofproto_v1_5_parser), 344	in	OFPEchoRequest	(class ryu.ofproto.ofproto_v1_4_parser), 276	in
OFPBundleCtrlMsg	(class ryu.ofproto.ofproto_v1_4_parser), 252	in	OFPEchoRequest	(class ryu.ofproto.ofproto_v1_5_parser), 366	in
OFPBundleCtrlMsg	(class ryu.ofproto.ofproto_v1_5_parser), 343	in	OFPErrorMsg	(class ryu.ofproto.ofproto_v1_0_parser), 80	in
OFPBundleFeaturesStatsReply	(class ryu.ofproto.ofproto_v1_5_parser), 338	in	OFPErrorMsg	(class ryu.ofproto.ofproto_v1_2_parser), 122	in
OFPBundleFeaturesStatsRequest	(class ryu.ofproto.ofproto_v1_5_parser), 337	in	OFPErrorMsg	(class ryu.ofproto.ofproto_v1_3_parser), 182	in
OFPControllerStatus	(class ryu.ofproto.ofproto_v1_5_parser), 364	in	OFPErrorMsg	(class ryu.ofproto.ofproto_v1_4_parser), 278	in
OFPControllerStatusStats	(class ryu.ofproto.ofproto_v1_5_parser), 376	in	OFPErrorMsg	(class ryu.ofproto.ofproto_v1_5_parser), 367	in
OFPControllerStatusStatsReply	(class ryu.ofproto.ofproto_v1_5_parser), 327	in	OFPExperimenter	(class ryu.ofproto.ofproto_v1_2_parser), 124	in
OFPControllerStatusStatsRequest	(class ryu.ofproto.ofproto_v1_5_parser), 327	in	OFPExperimenter	(class ryu.ofproto.ofproto_v1_3_parser), 185	in
OFPDescStats	(class ryu.ofproto.ofproto_v1_2_parser), 96	in	OFPExperimenter	(class ryu.ofproto.ofproto_v1_4_parser), 279	in
OFPDescStatsReply	(class ryu.ofproto.ofproto_v1_0_parser), 70	in	OFPExperimenter	(class ryu.ofproto.ofproto_v1_5_parser), 368	in

OFPExperimenterStatsReply (class ryu.ofproto.ofproto_v1_4_parser), 248	in	OFPFLOWStatsReply (class ryu.ofproto.ofproto_v1_3_parser), 146	in
OFPExperimenterStatsReply (class ryu.ofproto.ofproto_v1_5_parser), 339	in	OFPFLOWStatsReply (class ryu.ofproto.ofproto_v1_4_parser), 214	in
OFPExperimenterStatsRequest (class ryu.ofproto.ofproto_v1_4_parser), 248	in	OFPFLOWStatsReply (class ryu.ofproto.ofproto_v1_5_parser), 305	in
OFPExperimenterStatsRequest (class ryu.ofproto.ofproto_v1_5_parser), 339	in	OFPFLOWStatsRequest (class ryu.ofproto.ofproto_v1_0_parser), 71	in
OFPFFeaturesRequest (class ryu.ofproto.ofproto_v1_0_parser), 63	in	OFPFLOWStatsRequest (class ryu.ofproto.ofproto_v1_2_parser), 97	in
OFPFFeaturesRequest (class ryu.ofproto.ofproto_v1_2_parser), 85	in	OFPFLOWStatsRequest (class ryu.ofproto.ofproto_v1_3_parser), 145	in
OFPFFeaturesRequest (class ryu.ofproto.ofproto_v1_3_parser), 130	in	OFPFLOWStatsRequest (class ryu.ofproto.ofproto_v1_4_parser), 213	in
OFPFFeaturesRequest (class ryu.ofproto.ofproto_v1_4_parser), 191	in	OFPFLOWStatsRequest (class ryu.ofproto.ofproto_v1_5_parser), 304	in
OFPFFeaturesRequest (class ryu.ofproto.ofproto_v1_5_parser), 285	in	OFPFGetAsyncReply (class ryu.ofproto.ofproto_v1_3_parser), 175	in
OFPFLOWDescStatsReply (class ryu.ofproto.ofproto_v1_5_parser), 303	in	OFPFGetAsyncReply (class ryu.ofproto.ofproto_v1_4_parser), 257	in
OFPFLOWDescStatsRequest (class ryu.ofproto.ofproto_v1_5_parser), 302	in	OFPFGetAsyncReply (class ryu.ofproto.ofproto_v1_5_parser), 351	in
OFPFLOWMod (class ryu.ofproto.ofproto_v1_0_parser), 67	in	OFPFGetAsyncRequest (class ryu.ofproto.ofproto_v1_3_parser), 175	in
OFPFLOWMod (class ryu.ofproto.ofproto_v1_2_parser), 89	in	OFPFGetAsyncRequest (class ryu.ofproto.ofproto_v1_4_parser), 257	in
OFPFLOWMod (class ryu.ofproto.ofproto_v1_3_parser), 133	in	OFPFGetAsyncRequest (class ryu.ofproto.ofproto_v1_5_parser), 351	in
OFPFLOWMod (class ryu.ofproto.ofproto_v1_4_parser), 195	in	OFPFGetConfigReply (class ryu.ofproto.ofproto_v1_0_parser), 66	in
OFPFLOWMod (class ryu.ofproto.ofproto_v1_5_parser), 288	in	OFPFGetConfigReply (class ryu.ofproto.ofproto_v1_2_parser), 88	in
OFPFLOWMonitorReply (class ryu.ofproto.ofproto_v1_4_parser), 246	in	OFPFGetConfigReply (class ryu.ofproto.ofproto_v1_3_parser), 132	in
OFPFLOWMonitorReply (class ryu.ofproto.ofproto_v1_5_parser), 335	in	OFPFGetConfigReply (class ryu.ofproto.ofproto_v1_4_parser), 193	in
OFPFLOWMonitorRequest (class ryu.ofproto.ofproto_v1_4_parser), 244	in	OFPFGetConfigReply (class ryu.ofproto.ofproto_v1_5_parser), 287	in
OFPFLOWMonitorRequest (class ryu.ofproto.ofproto_v1_5_parser), 333	in	OFPFGetConfigRequest (class ryu.ofproto.ofproto_v1_0_parser), 65	in
OFPFLOWRemoved (class ryu.ofproto.ofproto_v1_0_parser), 78	in	OFPFGetConfigRequest (class ryu.ofproto.ofproto_v1_2_parser), 87	in
OFPFLOWRemoved (class ryu.ofproto.ofproto_v1_2_parser), 119	in	OFPFGetConfigRequest (class ryu.ofproto.ofproto_v1_3_parser), 132	in
OFPFLOWRemoved (class ryu.ofproto.ofproto_v1_3_parser), 179	in	OFPFGetConfigRequest (class ryu.ofproto.ofproto_v1_4_parser), 193	in
OFPFLOWRemoved (class ryu.ofproto.ofproto_v1_4_parser), 267	in	OFPFGetConfigRequest (class ryu.ofproto.ofproto_v1_5_parser), 286	in
OFPFLOWRemoved (class ryu.ofproto.ofproto_v1_5_parser), 356	in	OFPFGroupDescStats (class ryu.ofproto.ofproto_v1_2_parser), 110	in
OFPFLOWStats (class ryu.ofproto.ofproto_v1_2_parser), 98	in	OFPFGroupDescStatsReply (class ryu.ofproto.ofproto_v1_3_parser), 161	in
OFPFLOWStatsReply (class ryu.ofproto.ofproto_v1_0_parser), 71	in	OFPFGroupDescStatsReply (class ryu.ofproto.ofproto_v1_4_parser), 238	in

OFPGroupDescStatsReply	(class	in	183
	ryu.ofproto.ofproto_v1_5_parser),		
OFPGroupDescStatsRequest	(class	in	OFPHello (class in ryu.ofproto.ofproto_v1_4_parser),
	ryu.ofproto.ofproto_v1_2_parser),		276
OFPGroupDescStatsRequest	(class	in	OFPHello (class in ryu.ofproto.ofproto_v1_5_parser),
	ryu.ofproto.ofproto_v1_3_parser),		366
OFPGroupDescStatsRequest	(class	in	OFPHelloElemVersionBitmap (class in
	ryu.ofproto.ofproto_v1_4_parser),		ryu.ofproto.ofproto_v1_3_parser),
OFPGroupDescStatsRequest	(class	in	OFPHelloElemVersionBitmap (class in
	ryu.ofproto.ofproto_v1_5_parser),		ryu.ofproto.ofproto_v1_4_parser),
OFPGroupFeaturesStats	(class	in	OFPHelloElemVersionBitmap (class in
	ryu.ofproto.ofproto_v1_2_parser),		ryu.ofproto.ofproto_v1_5_parser),
OFPGroupFeaturesStatsReply	(class	in	OFPInstructionActions (class in
	ryu.ofproto.ofproto_v1_3_parser),		ryu.ofproto.ofproto_v1_2_parser),
OFPGroupFeaturesStatsReply	(class	in	OFPInstructionActions (class in
	ryu.ofproto.ofproto_v1_4_parser),		ryu.ofproto.ofproto_v1_3_parser),
OFPGroupFeaturesStatsReply	(class	in	OFPInstructionActions (class in
	ryu.ofproto.ofproto_v1_5_parser),		ryu.ofproto.ofproto_v1_4_parser),
OFPGroupFeaturesStatsRequest	(class	in	OFPInstructionActions (class in
	ryu.ofproto.ofproto_v1_2_parser),		ryu.ofproto.ofproto_v1_5_parser),
OFPGroupFeaturesStatsRequest	(class	in	OFPInstructionGotoTable (class in
	ryu.ofproto.ofproto_v1_3_parser),		ryu.ofproto.ofproto_v1_2_parser),
OFPGroupFeaturesStatsRequest	(class	in	OFPInstructionGotoTable (class in
	ryu.ofproto.ofproto_v1_4_parser),		ryu.ofproto.ofproto_v1_3_parser),
OFPGroupFeaturesStatsRequest	(class	in	OFPInstructionGotoTable (class in
	ryu.ofproto.ofproto_v1_5_parser),		ryu.ofproto.ofproto_v1_4_parser),
OFPGroupMod	(class	in	OFPInstructionGotoTable (class in
	ryu.ofproto.ofproto_v1_2_parser),		ryu.ofproto.ofproto_v1_5_parser),
OFPGroupMod	(class	in	OFPInstructionMeter (class in
	ryu.ofproto.ofproto_v1_3_parser),		ryu.ofproto.ofproto_v1_3_parser),
OFPGroupMod	(class	in	OFPInstructionMeter (class in
	ryu.ofproto.ofproto_v1_4_parser),		ryu.ofproto.ofproto_v1_4_parser),
OFPGroupMod	(class	in	OFPInstructionStatTrigger (class in
	ryu.ofproto.ofproto_v1_5_parser),		ryu.ofproto.ofproto_v1_5_parser),
OFPGroupStats	(class	in	OFPInstructionWriteMetadata (class in
	ryu.ofproto.ofproto_v1_2_parser),		ryu.ofproto.ofproto_v1_2_parser),
OFPGroupStatsReply	(class	in	OFPInstructionWriteMetadata (class in
	ryu.ofproto.ofproto_v1_3_parser),		ryu.ofproto.ofproto_v1_3_parser),
OFPGroupStatsReply	(class	in	OFPInstructionWriteMetadata (class in
	ryu.ofproto.ofproto_v1_4_parser),		ryu.ofproto.ofproto_v1_4_parser),
OFPGroupStatsReply	(class	in	OFPInstructionWriteMetadata (class in
	ryu.ofproto.ofproto_v1_5_parser),		ryu.ofproto.ofproto_v1_5_parser),
OFPGroupStatsRequest	(class	in	OFPMatch (class in ryu.ofproto.ofproto_v1_0_parser),
	ryu.ofproto.ofproto_v1_2_parser),		83
OFPGroupStatsRequest	(class	in	OFPMatch (class in ryu.ofproto.ofproto_v1_2_parser),
	ryu.ofproto.ofproto_v1_3_parser),		125
OFPGroupStatsRequest	(class	in	OFPMatch (class in ryu.ofproto.ofproto_v1_3_parser),
	ryu.ofproto.ofproto_v1_4_parser),		186
OFPGroupStatsRequest	(class	in	OFPMatch (class in ryu.ofproto.ofproto_v1_4_parser),
	ryu.ofproto.ofproto_v1_5_parser),		280
OFPHello (class in ryu.ofproto.ofproto_v1_0_parser),		in	OFPMatch (class in ryu.ofproto.ofproto_v1_5_parser),
OFPHello (class in ryu.ofproto.ofproto_v1_2_parser),		in	369
123			OFPMeterConfigStatsReply (class in
OFPHello (class in ryu.ofproto.ofproto_v1_3_parser),			ryu.ofproto.ofproto_v1_3_parser),
			165
			OFPMeterConfigStatsReply (class in
			ryu.ofproto.ofproto_v1_4_parser),
			242

OFPMeterConfigStatsRequest (class ryu.ofproto.ofproto_v1_3_parser), 165	in	OFPPacketOut (class ryu.ofproto.ofproto_v1_4_parser), 249	in
OFPMeterConfigStatsRequest (class ryu.ofproto.ofproto_v1_4_parser), 241	in	OFPPacketOut (class ryu.ofproto.ofproto_v1_5_parser), 340	in
OFPMeterDescStatsReply (class ryu.ofproto.ofproto_v1_5_parser), 325	in	OFPPhyPort (class in ryu.ofproto.ofproto_v1_0_parser), 82	
OFPMeterDescStatsRequest (class ryu.ofproto.ofproto_v1_5_parser), 324	in	OFPPort (class in ryu.ofproto.ofproto_v1_2_parser), 125	
OFPMeterFeaturesStatsReply (class ryu.ofproto.ofproto_v1_3_parser), 167	in	OFPPort (class in ryu.ofproto.ofproto_v1_3_parser), 185	
OFPMeterFeaturesStatsReply (class ryu.ofproto.ofproto_v1_4_parser), 243	in	OFPPort (class in ryu.ofproto.ofproto_v1_4_parser), 279	
OFPMeterFeaturesStatsReply (class ryu.ofproto.ofproto_v1_5_parser), 326	in	OFPPort (class in ryu.ofproto.ofproto_v1_5_parser), 369	
OFPMeterFeaturesStatsRequest (class ryu.ofproto.ofproto_v1_3_parser), 166	in	OFPPortDescStatsReply (class ryu.ofproto.ofproto_v1_3_parser), 157	in
OFPMeterFeaturesStatsRequest (class ryu.ofproto.ofproto_v1_4_parser), 243	in	OFPPortDescStatsReply (class ryu.ofproto.ofproto_v1_4_parser), 229	in
OFPMeterFeaturesStatsRequest (class ryu.ofproto.ofproto_v1_5_parser), 325	in	OFPPortDescStatsReply (class ryu.ofproto.ofproto_v1_5_parser), 312	in
OFPMeterMod (class ryu.ofproto.ofproto_v1_3_parser), 143	in	OFPPortDescStatsRequest (class ryu.ofproto.ofproto_v1_3_parser), 157	in
OFPMeterMod (class ryu.ofproto.ofproto_v1_4_parser), 210	in	OFPPortDescStatsRequest (class ryu.ofproto.ofproto_v1_4_parser), 229	in
OFPMeterMod (class ryu.ofproto.ofproto_v1_5_parser), 300	in	OFPPortDescStatsRequest (class ryu.ofproto.ofproto_v1_5_parser), 311	in
OFPMeterStatsReply (class ryu.ofproto.ofproto_v1_3_parser), 164	in	OFPPortMod (class in ryu.ofproto.ofproto_v1_0_parser), 68	
OFPMeterStatsReply (class ryu.ofproto.ofproto_v1_4_parser), 240	in	OFPPortMod (class in ryu.ofproto.ofproto_v1_2_parser), 94	
OFPMeterStatsReply (class ryu.ofproto.ofproto_v1_5_parser), 323	in	OFPPortMod (class in ryu.ofproto.ofproto_v1_3_parser), 141	
OFPMeterStatsRequest (class ryu.ofproto.ofproto_v1_3_parser), 164	in	OFPPortMod (class in ryu.ofproto.ofproto_v1_4_parser), 209	
OFPMeterStatsRequest (class ryu.ofproto.ofproto_v1_4_parser), 240	in	OFPPortMod (class in ryu.ofproto.ofproto_v1_5_parser), 298	
OFPMeterStatsRequest (class ryu.ofproto.ofproto_v1_5_parser), 323	in	OFPPortStats (class in ryu.ofproto.ofproto_v1_2_parser), 105	
OFPPacketIn (class in ryu.ofproto.ofproto_v1_0_parser), 77	in	OFPPortStatsReply (class ryu.ofproto.ofproto_v1_0_parser), 74	in
OFPPacketIn (class in ryu.ofproto.ofproto_v1_2_parser), 117	in	OFPPortStatsReply (class ryu.ofproto.ofproto_v1_3_parser), 156	in
OFPPacketIn (class in ryu.ofproto.ofproto_v1_3_parser), 177	in	OFPPortStatsReply (class ryu.ofproto.ofproto_v1_4_parser), 226	in
OFPPacketIn (class in ryu.ofproto.ofproto_v1_4_parser), 260	in	OFPPortStatsReply (class ryu.ofproto.ofproto_v1_5_parser), 309	in
OFPPacketIn (class in ryu.ofproto.ofproto_v1_5_parser), 354	in	OFPPortStatsRequest (class ryu.ofproto.ofproto_v1_0_parser), 74	in
OFPPacketOut (class ryu.ofproto.ofproto_v1_0_parser), 76	in	OFPPortStatsRequest (class ryu.ofproto.ofproto_v1_2_parser), 104	in
OFPPacketOut (class ryu.ofproto.ofproto_v1_2_parser), 114	in	OFPPortStatsRequest (class ryu.ofproto.ofproto_v1_3_parser), 155	in
OFPPacketOut (class ryu.ofproto.ofproto_v1_3_parser), 171	in	OFPPortStatsRequest (class ryu.ofproto.ofproto_v1_4_parser), 226	in
	in	OFPPortStatsRequest (class ryu.ofproto.ofproto_v1_5_parser), 308	in
	in	OFPPortStatus (class ryu.ofproto.ofproto_v1_0_parser), 79	in

ryu.ofproto.ofproto_v1_3_parser), 168
 OFPTableFeaturesStatsReply (class
 ryu.ofproto.ofproto_v1_4_parser), 226
 OFPTableFeaturesStatsReply (class
 ryu.ofproto.ofproto_v1_5_parser), 332
 OFPTableFeaturesStatsRequest (class
 ryu.ofproto.ofproto_v1_3_parser), 167
 OFPTableFeaturesStatsRequest (class
 ryu.ofproto.ofproto_v1_4_parser), 225
 OFPTableFeaturesStatsRequest (class
 ryu.ofproto.ofproto_v1_5_parser), 331
 OFPTableMod (class
 ryu.ofproto.ofproto_v1_2_parser), 89
 OFPTableMod (class
 ryu.ofproto.ofproto_v1_3_parser), 133
 OFPTableMod (class
 ryu.ofproto.ofproto_v1_4_parser), 194
 OFPTableMod (class
 ryu.ofproto.ofproto_v1_5_parser), 288
 OFPTableStats (class
 ryu.ofproto.ofproto_v1_2_parser), 104
 OFPTableStatsReply (class
 ryu.ofproto.ofproto_v1_0_parser), 73
 OFPTableStatsReply (class
 ryu.ofproto.ofproto_v1_3_parser), 154
 OFPTableStatsReply (class
 ryu.ofproto.ofproto_v1_4_parser), 222
 OFPTableStatsReply (class
 ryu.ofproto.ofproto_v1_5_parser), 328
 OFPTableStatsRequest (class
 ryu.ofproto.ofproto_v1_0_parser), 73
 OFPTableStatsRequest (class
 ryu.ofproto.ofproto_v1_2_parser), 103
 OFPTableStatsRequest (class
 ryu.ofproto.ofproto_v1_3_parser), 154
 OFPTableStatsRequest (class
 ryu.ofproto.ofproto_v1_4_parser), 222
 OFPTableStatsRequest (class
 ryu.ofproto.ofproto_v1_5_parser), 328
 OFPTableStatus (class
 ryu.ofproto.ofproto_v1_4_parser), 273
 OFPTableStatus (class
 ryu.ofproto.ofproto_v1_5_parser), 361
 OFPVendor (class in ryu.ofproto.ofproto_v1_0_parser),
 82
 OFPVendorStatsReply (class
 ryu.ofproto.ofproto_v1_0_parser), 76
 OFPVendorStatsRequest (class
 ryu.ofproto.ofproto_v1_0_parser), 76
 opt_header (class in ryu.lib.packet.ipv6), 22
 option (class in ryu.lib.packet.dhcp), 32
 option (class in ryu.lib.packet.ipv6), 22
 options (class in ryu.lib.packet.dhcp), 32
 organization_specific_tlv (class in ryu.lib.packet.cfm), 29

out_filter_get() (ryu.services.protocols.bgp.bgpspeaker.BGPSPeaker
 in method), 57
 out_filter_set() (ryu.services.protocols.bgp.bgpspeaker.BGPSPeaker
 in method), 58

P

pack() (ryu.lib.packet.bfd.bfd method), 51
 in Packet (class in ryu.lib.packet.packet), 16
 PacketBase (class in ryu.lib.packet.packet_base), 17
 in param_cookie_preserve (class in ryu.lib.packet.sctp), 48
 param_ecn (class in ryu.lib.packet.sctp), 48
 in param_heartbeat (class in ryu.lib.packet.sctp), 48
 param_host_addr (class in ryu.lib.packet.sctp), 49
 in param_ipv4 (class in ryu.lib.packet.sctp), 49
 param_ipv6 (class in ryu.lib.packet.sctp), 49
 in param_state_cookie (class in ryu.lib.packet.sctp), 49
 param_supported_addr (class in ryu.lib.packet.sctp), 49
 in param_unrecognized_param (class in ryu.lib.packet.sctp),
 50
 in parse() (ryu.lib.packet.stream_parser.StreamParser
 method), 17
 in parser() (ryu.lib.packet.packet_base.PacketBase class
 method), 17
 in port_status_tlv (class in ryu.lib.packet.cfm), 30
 prefix_add() (ryu.services.protocols.bgp.bgpspeaker.BGPSPeaker
 in method), 58
 prefix_del() (ryu.services.protocols.bgp.bgpspeaker.BGPSPeaker
 in method), 58
 PrefixFilter (class in ryu.services.protocols.bgp.info_base.base),
 in 59

R

register_packet_type() (ryu.lib.packet.packet_base.PacketBase
 in class method), 18
 reply_egress_tlv (class in ryu.lib.packet.cfm), 30
 in reply_ingress_tlv (class in ryu.lib.packet.cfm), 30
 reply_to_request() (ryu.base.app_manager.RyuApp
 in method), 378
 rib_get() (ryu.services.protocols.bgp.bgpspeaker.BGPSPeaker
 in method), 58
 routing (class in ryu.lib.packet.ipv6), 23
 in routing_type3 (class in ryu.lib.packet.ipv6), 23
 RstBPDUs (class in ryu.lib.packet.bpdu), 38
 ryu.app.cbench (module), 9
 ryu.app.ofctl.api (module), 399
 in ryu.app.ofctl.exception (module), 400
 ryu.app.simple_switch (module), 9
 in ryu.base.app_manager (module), 7
 ryu.controller.controller (module), 7
 ryu.controller.dpset (module), 7
 ryu.controller.ofp_event (module), 7
 ryu.controller.ofp_handler (module), 7
 ryu.lib.netconf (module), 9
 ryu.lib.of_config (module), 9

ryu.lib.ovs (module), 9
 ryu.lib.packet (module), 9
 ryu.lib.packet.arp (module), 19
 ryu.lib.packet.cfm (module), 26
 ryu.lib.packet.ethernet (module), 18
 ryu.lib.packet.icmp (module), 20
 ryu.lib.packet.icmpv6 (module), 23
 ryu.lib.packet.ipv4 (module), 19
 ryu.lib.packet.ipv6 (module), 21
 ryu.lib.packet.mpls (module), 19
 ryu.lib.packet.packet (module), 16
 ryu.lib.packet.packet_base (module), 17
 ryu.lib.packet.pbb (module), 19
 ryu.lib.packet.sctp (module), 42
 ryu.lib.packet.stream_parser (module), 17
 ryu.lib.packet.tcp (module), 31
 ryu.lib.packet.udp (module), 31
 ryu.lib.packet.vlan (module), 18
 ryu.lib.xflow (module), 9
 ryu.ofproto.nx_match (module), 377
 ryu.ofproto.ofproto_v1_0 (module), 7
 ryu.ofproto.ofproto_v1_0_parser (module), 7
 ryu.ofproto.ofproto_v1_2 (module), 7
 ryu.ofproto.ofproto_v1_2_parser (module), 8
 ryu.ofproto.ofproto_v1_3 (module), 8
 ryu.ofproto.ofproto_v1_3_parser (module), 8
 ryu.ofproto.ofproto_v1_4 (module), 8
 ryu.ofproto.ofproto_v1_4_parser (module), 8
 ryu.ofproto.ofproto_v1_5 (module), 8
 ryu.ofproto.ofproto_v1_5_parser (module), 8
 ryu.topology (module), 9
 RyuApp (class in ryu.base.app_manager), 378

S

sctp (class in ryu.lib.packet.sctp), 50
 send_event() (ryu.base.app_manager.RyuApp method), 378
 send_event_to_observers() (ryu.base.app_manager.RyuApp method), 378
 send_msg() (in module ryu.app.ofctl.api), 399
 send_request() (ryu.base.app_manager.RyuApp method), 378
 sender_id_tlv (class in ryu.lib.packet.cfm), 30
 serialize() (ryu.lib.packet.bfd.KeyedMD5 method), 52
 serialize() (ryu.lib.packet.bfd.KeyedSHA1 method), 53
 serialize() (ryu.lib.packet.bfd.SimplePassword method), 52
 serialize() (ryu.lib.packet.packet.Packet method), 16
 serialize() (ryu.lib.packet.packet_base.PacketBase method), 18
 shutdown() (ryu.services.protocols.bgp.bgpspeaker.BGPSpeaker method), 58
 SimplePassword (class in ryu.lib.packet.bfd), 51

slow (class in ryu.lib.packet.slow), 33
 start() (ryu.base.app_manager.RyuApp method), 379
 StreamParser (class in ryu.lib.packet.bgp), 17
 StreamParser (class in ryu.lib.packet.stream_parser), 17
 svlan (class in ryu.lib.packet.vlan), 18

T

tcp (class in ryu.lib.packet.tcp), 31
 TimeExceeded (class in ryu.lib.packet.icmp), 20
 to_jsondict() (ryu.ofproto.ofproto_parser.MsgBase method), 62
 TopologyChangeNotificationBPDUs (class in ryu.lib.packet.bpdu), 38
 try_parse() (ryu.lib.packet.stream_parser.StreamParser method), 17

U

udp (class in ryu.lib.packet.udp), 31
 UnexpectedMultiReply, 400

V

vlan (class in ryu.lib.packet.vlan), 18
 vrf_add() (ryu.services.protocols.bgp.bgpspeaker.BGPSpeaker method), 58
 vrf_del() (ryu.services.protocols.bgp.bgpspeaker.BGPSpeaker method), 58
 vrrp (class in ryu.lib.packet.vrrp), 32
 vrrpv2 (class in ryu.lib.packet.vrrp), 33
 vrrpv3 (class in ryu.lib.packet.vrrp), 33